



Lighting the
way ahead

Lighting the
way ahead



Lighting the way ahead
Photonics21 Strategic Research Agenda

Published by
European Technology Platform Photonics21

Secretariat Photonics21:
VDI Technologiezentrum
VDI-Platz 1
40468 Düsseldorf, Germany
Phone: +49 / 211 / 62 14-338
Phone: +49 / 211 / 62 14-478
Fax: +49 / 211 / 62 14-484
e-mail: secretariat@Photonics21.org
www.Photonics21.org

Second edition, January 2010

Coordinating editors:
VDI Technologiezentrum
Katharina Flaig
Markus Wilkens

Special thanks to
Tony Jones, copy editor

Design and layout:
pr+co. gmbh
Agentur für Kommunikation
Fuchseckstraße 7
70188 Stuttgart, Germany

Lithography:
Reprotechnik Herzog GmbH
70439 Stuttgart, Germany

Printing:
frechdruck GmbH
70499 Stuttgart, Germany

Cover photo copyright: Fotolia

Contributing authors:

Jean-Thierry Audren,
Sagem Défense Sécurité

Jan Andersson, Acreo AB

Roel Baets,
University of Gent

Susanne Bieller, VDMA

Petra Bindig,
European Optical Society

Sébastien Bigo,
Alcatel-Lucent

Jan Blochwitz-Nimoth,
Novaled

Andy Carter, Oclaro

Thierry Clapp,
Dow Corning

David Cotter,
Tyndall Institute

Matthias Dämmig,
ZETT OPTICS

Chris Dainty,
National University of
Ireland, Galway

Sandro De Silvestri,
Politecnico di Milano

Carlos Dominguez, CSIC

Jörg-Peter Elbers,
ADVA

Jim Everett, Ericsson

Robert Fischer,
Vrije Universiteit
Brussels

Pierre-Yves Fonjallaz,
ACREO

Andreas Friedel, Trumpf

Laurent Fulbert,
CEA-LETI

Stéphane Gosselin,
France-Télécom/Orange
Labs

Hans-Joachim Grallert,
Fraunhofer Heinrich
Hertz Institute

Augustin Grillet, Barco

Pietro Guiseppa Guc-
ciardi, CNR Messina

Eliav Haskal,
Philips Research

Hans Peter Herzig,
Ecole Polytechnique
Fédérale de Lausanne

Alain Jalocha, CILAS

Jean-Michel Jonathan,
Institut d'Optique

Jean-Paul Judson,
POPSud

Stefan Kaierle,
Fraunhofer-Institut für
Lasertechnik

Markus Klemmt, Laser
Zentrum Hannover

Wolfgang Knapp,
Centre des Matériaux
Mines Paris, Paristech

Eric Larkins, University
of Nottingham

Michael Lebbly,
OIDA

Thomas Mayerhöfer,
Institut für Photonische
Technologien e.V.

Daniel Milanese,
Politecnico di Torino

Jürgen Mohr, Karlsruhe
Institute of Technology

Bruce Napier,
Gooch & Housego

Bimal Nayar,
Ericsson

Michael Parker,
Essex University

Tom Pearsall, EPIC

Christopher Pickering,
QinetiQ

Angela Piegari,
ENEA

Jürgen Popp,
Institut für Photonische
Technologien e.V.

Roberta Ramponi,
Politecnico di Milano

Detlev Ristau,
Laser Zentrum Hannover

Thierry Robin, Optineos

Wolfgang Sandner,
Max-Born-Institut

Laurent Sarger,
Université Bordeaux 1

Bruno Smets,
Philips Lighting

Meint Smit, Technical
University Eindhoven

Frank Stietz, Carl Zeiss

Katarina Svanberg,
Lund University Hospital

Hugo Thienpont, Vrije
Universiteit Brussels

Lars Thylén, KTH Royal
Institute of Technology

Lluis Torner, ICFO –
The Institute of Photonics
Sciences

Marc Tremont, Carl Zeiss

Alfredo Viglienzoni,
Ericsson

Peter Visser,
Philips Lighting

Mike Wade,
Oclaro

Godehard Wolf,
Fraunhofer Heinrich
Hertz Institute

Stuart Walker,
Essex University

Berit Wessler, OSRAM
Opto Semiconductors

Ulrich Wittrock,
University of Applied
Sciences Münster

Photonics21 Executive Board

President	Martin Goetzeler, CEO, OSRAM
Vice Presidents	Bernd Schulte, Executive Vice President and COO, Aixtron Malgorzata Kujawska, Warsaw University of Technology Giorgio Anania, Chairman, Cube Optics
Working Group Chairs Information and Communication	Alfredo Viglienzoni, Head Optical Products, Ericsson
Industrial Production/ Manufacturing and Quality	Eckhard Meiners, CEO, Trumpf Laser Marking Systems
Life Sciences and Health	Ulrich Simon, CEO & President, Carl Zeiss Microlmaging
Lighting and Displays	Klaas Vegter, CTO, Philips Lighting
Security, Metrology and Sensors	Jean-Francois Coutris, Vice President, SAGEM DS
Design and Manufacturing of Components and Systems	Mike Wale, Director Active Products Research, Oclaro
Photonics Education, Training and Research Infrastructure	Roberta Ramponi, Professor, Politecnico di Milano
Secretariat Photonics21	VDI Technologiezentrum



Lighting the way ahead

It is my pleasure to present to you the second Strategic Research Agenda, prepared by Photonics21, the European Technology Platform representing the photonics community in Europe.

When the first agenda was published in 2006, photonics in Europe looked very different. Photonics21 had only just begun its task of building a community. We were learning to cooperate more closely, to discover our strengths and to join forces to stay competitive. We were taking our first steps towards mapping out a shared vision for the future.

Today more than 5 000 companies, most of them small and medium-size enterprises, manufacture photonics products in Europe. The sector employs almost 300 000 people directly and many more work for its suppliers. No fewer than 40 000 jobs have been created here in Europe within the last four years.

Photonics innovations are key drivers for profitable growth. The world market for photonics products reached €270 billion in 2008, of which €55 billion was produced in Europe — a growth of nearly 30% since 2005. We are particularly strong in lighting, manufacturing technology, medical technology, defence photonics and optical components and systems.

In September 2009 the European Commission designated photonics as one of five key enabling technologies for our future prosperity. This signifies not only the economic importance of photonics, but its potential to address what have been called the ‘grand challenges’ of our time.

In these pages you will learn how solid-state lighting can cut our use of energy and stave off the effects of climate change, how photonic instruments can help diagnose cancer much earlier than is now possible, and how superfast fibre-optic networks can make the knowledge society a reality.

You will also discover, on the fiftieth anniversary of its invention, how the laser is set to become a versatile manufacturing tool. One of our proposed actions will see lasers used to mass-produce the next generation of photovoltaic solar panels, which themselves will reduce our reliance on fossil fuels. This is just one example of the emerging area of ‘green photonics’ which has the potential to lead us into an energy-saving future.

But technological breakthroughs do not just happen. If photonics is to flourish in Europe, as we believe it can, we need many more skilled scientists, engineers and technicians than we have today. That is not a challenge just for photonics but for us all.

After four years in which significant progress has been made, this second Strategic Research Agenda is our new vision for the future direction of photonics in Europe. If we are successful in achieving the targets addressed, then Europe will be able to take the lead in the technology that is driving innovation in the twenty-first century. It is an ambitious vision but, if we act together, we can make this vision happen.

A handwritten signature in black ink that reads "Martin Goetzeler". The signature is written in a cursive, flowing style.

Martin Goetzeler, Photonics21, President and Chief Executive Officer, OSRAM

Contents

<i>page 6</i>	1.0	Executive summary
<i>page 12</i>	2.0	Photonics in Europe
	2.1	Photonics21 – Towards a joint strategy for Europe
	2.2	Photonics – a key technology in the spotlight
	2.3	Economic and social impact
<i>page 22</i>	3.0	Photonic solutions to the main challenges facing European society
	3.1	Challenges to European society
	3.2	Photonic solutions as a response
	3.3	Green photonics and its impact on global climate
	3.4	Energy-efficient lighting
	3.5	Renewable energy generation
	3.6	Europe's ageing society
	3.7	The European information and knowledge society
	3.8	Safety and security
<i>page 52</i>	4.0	Research strategy for boosting the European economy
	4.1	Information and communication
	4.2	Manufacturing and quality
	4.3	Healthcare and life science
	4.4	Lighting and displays
	4.5	Photonics for safety and security
	4.6	Cutting-edge materials and technologies
<i>page 158</i>	5.0	Education, training and research infrastructures in photonics
<i>page 170</i>	6.0	Implementing the Strategic Research Agenda
	6.1	Conclusions
	6.2	Key challenges
	6.3	Key recommendations
<i>page 176</i>	7.0	Glossary



1.0

Executive summary

1.1

About Photonics21

Photonics is the science and technology of the harnessing of light. Photonics encompasses the generation of light, the detection of light, the management of light through guidance, manipulation and amplification, and most importantly its utilisation for the benefit of mankind. Photonics bears the same relationship to light and photons as electronics does to electricity and electrons. It has been defined as a key enabling technology by the European Commission.

Photonics21 is a European Technology Platform founded in 2005 with the support of the European Commission to develop a coordinated strategy for the photonics community in Europe. The members of Photonics21 are representatives of the European photonics industry, research institutions and universities. Membership has grown from 250 in 2005 to more than 1400 in 49 countries, including all 27 member states of the European Union. Photonics21 is organised in seven working groups, the Board of Stakeholders and the Executive Board.

In 2006 Photonics21 published its first Strategic Research Agenda which set out research priorities for the next four years. Photonics21 has now developed the second Strategic Research Agenda – this document – to further develop European scientific, technological and economic leadership in photonics.

Photonics21 believes that now is the time to focus on photonics applications and on its potential to address the challenges facing European society. In a real sense, our future will be made by light.

1.2

Social and economic impact of photonics

According to the Lund Declaration of July 2009, European research must focus on the ‘grand challenges’ of our time. Photonics is well placed to tackle such challenges as healthcare in an ageing society, energy efficiency and climate change, the knowledge society, the digital divide and public safety and security. The photonics community has identified a number of technological ‘megatrends’ including solid-state lighting, green communication networks, photonics-related cancer diagnosis, mass-customisation in manufacturing and autonomous sensor networks.

In 2008 the global photonics market was €270 billion, of which Europe took €55 billion, corresponding to a share of more than 20% of the worldwide production volume in the photonics industry. In Europe, more than 5 000 companies are involved in photon-

ics, most of them SMEs. The core sectors are lighting, production technology, medical technology, defence photonics and optical components and systems with market shares ranging from 25 to 45%. Europe has particularly strong positions in industrial laser technologies, information and communication, biophotonics and lighting.

Photonics companies themselves employ about 290 000 people in Europe, with sub-contractors employing many others. The sector is based on SMEs, where growth in demand will create proportionally more jobs than in a sector made up of big companies. If Europe gains the technological lead in photonics this will create new jobs in industrial manufacturing of new consumer goods. New photonic technologies will keep manufacturing jobs in Europe.

1.3

Industrial technologies

Information and communication

Information and communication technology (ICT) contributes to improvements in health-care (e-health), government (e-government) and education through increased web access. It also benefits our social lives.

Photonic technologies are at the heart of the ICT infrastructure, which relies heavily on fibre optic communications. Photonics will increase the reliability and pervasiveness of ICT. Access to photonics-enabled web-based services and the speed and quality of those connections will contribute to the competitiveness of people and communities.

We recommend that research focus on using optical technologies to make future networks more transparent, more dynamic, faster and consume less energy. Everybody in the EU should have access of at least 1 Mbit/s at home for fast communication. This will include a large-scale action to create 'digital villages' where high-speed internet systems can be tried out in realistic conditions.

Manufacturing and quality

Lasers can be used as a versatile manufacturing tool. Europe has a leading position in industrial laser technologies – in developing, supplying and applying lasers and laser systems.

Future high-volume applications will generate a demand for laser systems to machine high-strength steels, build lightweight and crash-safe structures to manufacture photovoltaic cells and semiconductors and miniaturised components for use in medical technology. The trend towards customisation and the growing importance of industrial design, for example in consumer electronics, will require new methods to make new product shapes and 'lot size one' production capabilities.

We recommend that research focus on all steps in the manufacturing process, from basic research and development to the products themselves and their market penetration. This will include a large-scale action to develop photonic tools used for the manufacture of photovoltaic solar cells.

Healthcare and life science

An ageing population brings with it increased demands on our healthcare systems. We need a paradigm shift to reduce healthcare costs while maintaining quality of life. Today, illnesses are treated according to the symptoms; in future it will be possible to detect and cure illness before.

Screening and medical imaging methods based on photonics will strengthen preventive medicine and the early detection of diseases. Non-invasive or minimally invasive treatments (therapeutic laser systems) will help to improve patients' lifestyle and mobility.

By combining microfluidics with photonics we can make ultra-sensitive 'lab on a chip' biosensors. These sensors can measure minute amounts of substances in small sample volumes and make it possible to assess patients rapidly at bedside.

We are moving into the era of personalised medicine. Innovative microscopes and endoscopes will help us to understand cell processes, tissues and model organisms and so support the development of drugs specific to the patient.

We recommend that research focus on diagnostic tools and treatments for cancer, eye diseases and sepsis, and on tools for preclinical research. This will include a large-scale action to develop new photonic methods for early diagnosis of cancer.

Lighting and displays

An important way to limit carbon dioxide emissions is to reduce the amount of electricity consumed by lighting. We require a paradigm shift to move from conventional technologies of incandescent and gas-discharge lamps to new, energy-efficient technologies in solid-state lighting based on electroluminescence by inorganic (LED) and organic (OLED) semiconductors.

Although Europe is no longer a major player in the mass market for consumer displays, it retains strengths in materials and advanced information displays and energy-efficient displays.

We recommend that research focus on the development of solid-state lighting and on displays for special applications. This will include a large-scale action to promote research, development and market deployment of solid-state lighting. Much of the research on lighting will also be relevant to displays.

Safety and security

Photonics can help protect the safety and security of European citizens. The use of light is well suited to remote, contactless sensing and measurement. Its short wavelength is ideal for sensing the detailed geometry of objects for more reliable recognition and fewer false alarms.

Safety applications include equipment for detecting pollution and driver assistance systems to improve road safety.

Security applications include biometrics and border surveillance systems, video surveillance systems and equipment to detect dangerous and illegal goods.

We recommend that safety and security research focus on improved, high-quality imaging and detection systems. This will include a large-scale action to develop autonomous, wireless sensor networks using photonics technology.

Cutting-edge materials and technologies

We have identified two fields of research in photonics that have particular strategic importance for the European economy and society: one is emerging photonic materials and the other is new technologies and functional devices, including nanophotonic devices, allowing the convergence of photonic and electronic technologies along with photonic integration technologies.

1.4

Education and training

There is a shortage of well-qualified employees in photonics. Concerted action is needed at all levels of education from primary level through to postgraduate level. We need a coherent programme of outreach activities and educational materials to promote photonics in schools. Industry and universities should work together to offer relevant courses at undergraduate and postgraduate levels as well as opportunities for lifelong learning for those already at work in the photonics industry. Although research relevant to industry is important, universities must not lose sight of their role in supporting research driven by curiosity and imagination.

1.5

Key recommendations

The photonics community has drawn up the following seven key recommendations which are addressed to the photonics industry, research institutions, the EU member states and the European Commission. They describe actions which should be taken at the European level to prepare the way for future photonics applications.

1. We must establish effective instruments for photonics

The European photonics community urgently needs effective instruments which combine transnational research with demonstrations of new technologies. These instruments will help the photonics community achieve its goals and respond to the pressing needs of society. Strategically relevant areas, such as solid-state lighting, need a large-scale, joint effort between industry, academia and public authorities. Such instruments would support development from basic research through to deployment and the market launch of products. European funding in photonics should combine research and deployment more strongly.

2. EU member states should set up photonics programmes

The EU member states should increase their national investments in photonics. Although countries like France, Italy and Spain have a particularly strong industrial base in photonics they have not yet set up national funding programmes that address the field as a whole. Many member states have world-class scientific excellence in photonics but national strategies are needed to translate such excellence into marketable products. Member states should further enhance cooperation with their European partners and support transnational research to bring together distinguished partners from industry and academia.

3. The European Commission should double its funding for photonics

Photonics is a key enabling technology in Europe. EU funding is directed to those research topics which are riskier or take longer than what industry could normally support, but which are still vital for the future of the photonics industry. It also facilitates greater cooperation amongst players at European level than would otherwise occur. However, the current budget dedicated to photonics by the European Commission does not match the field's strategic importance. This budget supports several sectors where there is significant market potential, but does not achieve the critical mass needed for leadership in any one of these sectors. Europe needs to at least double its public investment in photonics.

4. The photonics industry should invest 10% of turnover in R&D

The European photonics industry is especially supportive of short- and medium-term research which is vital for bringing new products to market. Investment in R&D is essential for European companies to stay competitive. The photonics industry should be prepared to increase its investment in R&D to 10% of its overall annual turnover, or some €5 billion. This will stimulate and support research and deployment in lighting, healthcare, information and communication, safety and security, and industrial manufacturing.

5. SMEs should have access to a capital fund for photonics

The further development of the photonics industry in Europe depends on improved access to capital markets, especially for SMEs with limited capital resources. Flexible financing concepts for industrial photonics are needed which respect the special needs of SMEs during the seed and growth phases. A dedicated European industrial photonics seed and growth fund providing long-term financial support would be a suitable instrument to foster growth in industrial photonics. Such a fund could also ensure the supervision and support needed by management at start-up companies. Financing could be provided by the European Investment Bank in cooperation with investment banks in the EU member states.

6. We must cooperate with other parts of the world to develop green photonics

EU member states and the European Commission should set up a framework for international cooperation especially with the United States. This cooperation should concentrate on selected areas in green photonics, principally solid-state lighting and photovoltaics. Close international cooperation will drive further advances in R&D and stimulate the growth of the photonics industry. It will also set the standards required for widespread adoption of the new lighting and photovoltaic technologies.

7. We must work together to develop a skilled workforce for photonics

Estimates indicate that, in the next ten years, Europe will need 80 000 new and qualified experts in photonics to cope with rapid industry growth and the retirement of skilled workers. EU member states, public authorities and the photonics community should pool their efforts so as to develop a workforce with the skills needed to meet the challenges of the future. If photonics is to thrive in Europe, then we have no alternative. ●○○



2.0

Photonics in Europe

Fig. 2 Europe by night
© NASA



Photonics is everywhere in our lives

Today, photonics is everywhere in our lives. We largely rely on photonic technologies when we switch on the light at home or in the office, when we surf the internet, watch a laser show or pass through the security check at the airport. Photonics underpins many of the technologies our society has come to depend on. In the twenty-first century, the photon will increasingly guide us towards a sustainable future within Europe. If we just think of global climate, energy efficiency, mobility, healthcare as well as of a modern European factory, the use of the photon is a constant key driver for technological innovation and progress.



2.1

Photonics21 — Towards a joint strategy for Europe

Photonics21 unites the majority of leading photonic industries and relevant R&D stakeholders

This document is the Second Strategic Research Agenda (SRA) of the European Technology Platform Photonics21. It was jointly developed and adopted by the members of Photonics21 between January and December 2009. The chapters by the individual workgroups present topics and research areas that were identified and discussed by about 450 participants at 17 workshops taking place all over Europe.

Photonics21 was founded in December 2005 with 250 members. The platform is based on an industry-led initiative encouraged by the European Commission in 2004. Today, Photonics21 comprises more than 1400 members from 49 countries, including the 27 EU member states. Photonics21 has a balanced composition between members from industry (both manufacturers and users of optical technologies) and members from academia. About three quarters of the industrial members represent small and medium-sized enterprises (SMEs). Photonics21 unites the majority of leading photonic industries and relevant R&D stakeholders along the whole value addition chain throughout Europe.

Photonics has been identified as a key enabling technology

After four years of operation Photonics21 has put the photonics community in Europe on a firm footing. There is a shared view among all members that transnational cooperation between industry and academia is the only way forward if Europe is to become more competitive in photonics. On the political level, EU member states have begun to coordinate their funding activities through the Photonics21 mirror group. Public authorities increasingly regard photonics as a strategic technology for Europe. Only recently the European Commission identified photonics as a key enabling technology.¹

The Second Photonics²¹ Strategic Research Agenda aims to further develop Europe's scientific, technological and economic leadership in photonics. As we need a common European approach for research and development in photonics in order to respond to the social challenges of the future, the SRA pursues the following objectives:

- establishing strategic links among mainly SME-based photonics industries as well as with key user industries and aligning common R&D efforts accordingly;
- ensuring that knowledge generated through research is transformed into leading-edge technologies and processes, and ultimately into marketable products and services which are competitive in the global market;
- agreeing on a common European photonics R&D strategy to tap the full economic potential of photonics;
- providing for the necessary research environment capable of accelerating photonics research, enhancing cooperation, increasing public and private R&D investment and ensuring the mobilisation of a critical mass of resources;
- responding to urgent questions of energy efficiency and sustainability;
- providing photonic solutions to support an ageing population;
- supporting the further development of the knowledge society;
- responding to urgent questions in the fields of safety and security;
- presenting new photonic technologies for the most important challenges and needs of European society.

We need a common European approach for research and development in photonics to respond to the social challenges

Figure 2.1.1 Photonics²¹ work groups

Source: Secretariat Photonics²¹

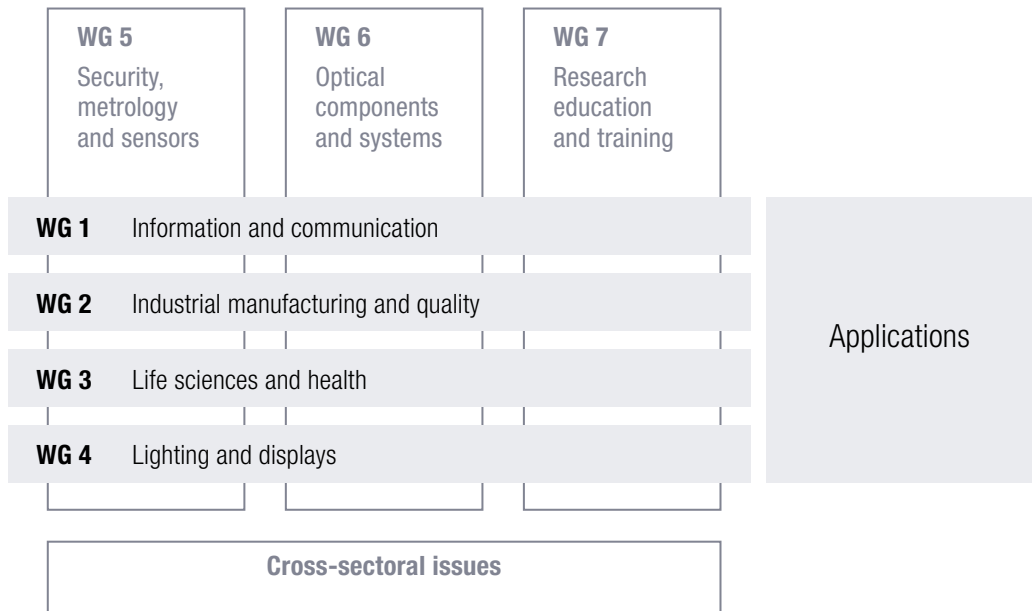

1 "Preparing for our future: Developing a common strategy for key enabling technologies in the EU", Communication from the Commission to the European Parliament, the Council, the European Economic and Social Committee, and the Committee of the Regions, September 30, 2009

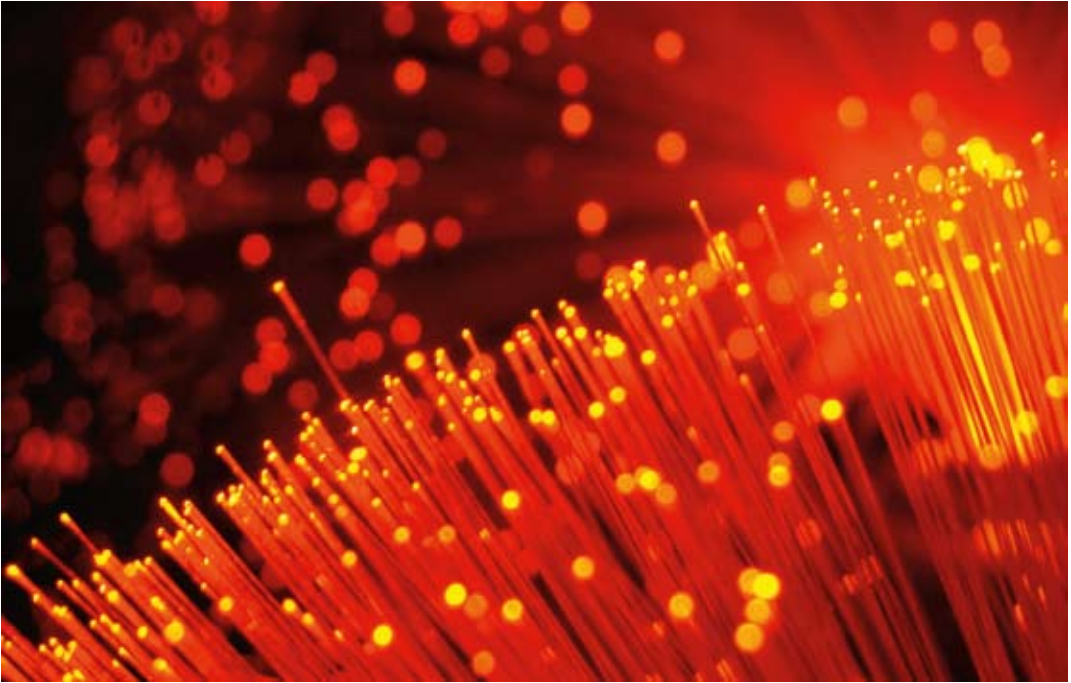

Fig. 2.2.1 Optical fibers are indispensable for the knowledge society © Fotolia

2.2

Photonics — a key technology in the spotlight

Today, photonics comprises a huge range of scientific and technological applications

Photonics is the science and technology of harnessing light. Photonics encompasses the generation, detection and management of light through guidance, manipulation, and amplification, and most importantly, its utilisation for the benefit of mankind. Photonics as a research discipline started in 1960 with the invention and the introduction of the laser and the laser diode. This development was followed in the 1970s by the deployment of optical fibres as a medium for transmitting information using light beams. In the following years, these new developments led to the revolution in telecommunications that provided the infrastructure of the internet. The global expansion of the internet was a result of this progress in optics and photonics and connected the whole world. The term 'photonics' came into common use in the 1980s when fibre-optic transmission of electronic data was adopted by telecommunications network operators. Today, photonics comprises a huge range of scientific and technological applications including laser-based manufacturing, biological and chemical sensing, medical diagnostics and therapy, lighting and display technology as well as optical computing.

In 2009, the Nobel Prize in physics was awarded to fibre-optics pioneer Charles K. Kao, whose work formed the basis of modern telecommunications, and to Willard S. Boyle

and George E. Smith, the inventors of digital imaging chips. Kao's work showed that optical technologies and photonics are essential to the future of telecommunications. His scientific work laid the foundation for our modern information society.¹ This historic revolution in photonics made a significant contribution to the development of our global communication system and made possible the development of the global knowledge society in which Europe plays a leading role. This progress in information and communication was based on the properties of light as well as on the understanding of the interactions between light and matter. In the years to come the revolutionary insights of photonics will further shape the future of our continent as well as of the whole planet.

The revolutionary insights of photonics will further shape the future of our continent

In 2010, researchers in photonics and optics as well as representatives of industry and politics will celebrate 50 years of the laser and 50 years of photonics. The laser is an important optical tool which will feature widely in the media and in international conferences. The anniversary reminds us of the enormous development of photonic technologies and solutions within the last five decades and its impact on progress in medicine, lighting, information and communication and manufacturing. The great public interest in '50 years of the laser' shows the huge potential of the new photonic technologies and applications that lie ahead.



Fig. 2.2.2 Visible laser radiation © Rofin-Sinar Laser GmbH

1 Gunnar Ocquist, the Academy's secretary general

2.3

Economic and social impact

The European production volume increased to €55 billion in 2008

In the twenty-first century, photonics is a driver for technological innovation as well as one of the most important key technologies for markets and products such as photonic systems, components and optical consumer goods. Yet the economic impact of photonics extends well beyond these products.

Since Photonics21 was established in 2005, the dynamic photonics industry and market have grown considerably. The world market for photonics grew from €226 billion in 2005 to €270 billion in 2008, representing an increase of about 20%. The European photonics industry benefited disproportionately from this positive trend, increasing production volume by 30% from €43.6 billion in 2005 to €55 billion in 2008. Moreover, more than 5 000 European companies created over 40 000 additional jobs in Europe in the same period.¹ Europe accounts for more than 20% of the worldwide production volume in the photonics industry. In its core sectors such as lighting, production technology, medical technology, defence photonics and optical components and systems, market shares around the globe range from 25% to 45%. Photonics products also provide decisive competitive advantages for other vital European industries which still have production sites in Europe.



Fig. 2.3.1
The economic impact of photonics goes beyond the output of the photonics industry
© Fotolia

¹ Optech Consulting, 2009, data for the photonics market in Europe and the global photonics market



Fig. 2.3.2 Photonics has an enormous potential in manufacturing © Fotolia

At the same time photonics will significantly contribute to solving the most important challenges Europe is facing such as the transition towards a low-carbon economy, environmental protection, border security and public health.

Today, the technological leadership of photonics is evident in the application of laser systems for material processing in the automotive, aeronautics and microelectronics industries. Photonic components are used within larger systems such as the lasers that lie at the heart of any DVD or CD device. Many other high-tech consumer products rely on photonic technology as well. Photonics clearly has a leverage effect because it creates different systems and products that multiply the value of the photonic components and technologies many times over.

Europe is strong in several different photonics sectors and industries. The European lighting industry holds a share of about 40% of the world's lamp market. The further technological development of solid-state light sources (LEDs and OLEDs) and of energy-efficient lighting systems taking place in Europe will give us a leading position on the world lighting market.

Europe leads the international market for industrial laser technologies. Many of the world's largest laser companies have their headquarters in Europe. In order to stay competitive with Asian companies, we have to further invest in innovative laser technology and to guarantee the high quality of European laser systems and components.

European companies play a leading role in healthcare and life science and their current market share is more than 30%². The further development of optical components and systems will help Europe to maintain its leading position in the global market.

Technological progress in materials science, microelectronics and information technology will help European manufacturers to offer better and more innovative products and services to their customers. Innovation in production processes will change the scale

² Photonics21, Optech Consulting, Photonics in Europe – Economic Impact



Fig. 2.3.3 Laser processing system for cutting and welding © TRUMPF GmbH + Co. KG

of manufacturing as well as the organisational pattern in industry. Photonics as a key driver of technology will offer various solutions for European manufacturing in the future. Laser-based production processes offer an enormous potential for highly flexible production on demand. Technological progress in lighting will also increasingly stimulate the manufacturing sector.

Employment

Photonics has a large impact on employment in Europe in three ways:

1. The photonics industry is mainly based on SMEs. Growth in demand will create proportionally more jobs in SMEs than it will in any sector made up of big companies.
2. New photonic technologies will secure the competitiveness of existing industries and so maintain jobs in manufacturing which are threatened by companies moving production to low-wage countries outside the EU.
3. Gaining the technological lead in photonics will enable us to create new manufacturing jobs for novel consumer products such as solid-state lighting (LEDs and OLEDs) and multimedia devices.

*Photonics is
a significant
creator of
jobs through-
out Europe*

Today, the photonics industry employs about 290 000 people all over Europe, not including employment with subcontractors. In comparison to 246 000 employees in 2005, this enormous increase shows that photonics is a significant creator of jobs throughout Europe.³ As a cross-sectoral technology, photonics has a strong impact on numerous other industries. It triggers important innovations in areas such as mechanical, automobile and aircraft engineering, microelectronics and the medical devices industry, where

Europe holds particular expertise. This clearly illustrates the enormous importance of photonic solutions and technologies within Europe.

Photonics contributes greatly to the European economy. We must ensure that the photonics sector continues to grow in order to secure employment and to guarantee the continuing competitiveness of our economy in the face of global competition.

If we promote and support the manufacturing of high quality products in Europe, we will guarantee the further creation of employment in photonics throughout Europe.

Impact on society

According to the Lund Declaration of July 2009, Europe must focus strongly on the 'grand challenges' of our time. This means that European research institutions and industry are expected to offer solutions to problems such as global warming, the ageing society, public health and security.⁴

If we think of the urgent need to improve healthcare and prevent disease, photonic technologies directly come to mind. Their enormous potential to offer technological innovations in medicine and life science will further contribute to the good health of European society.

Information and communication play a vital role in every society. The information society strongly relies on photonics and will only make further progress if we invest in these key technologies. As a driver for technological innovation, photonics will lead Europe to the knowledge society of tomorrow.

The need to save energy and reduce carbon dioxide emissions has become an imperative. Truly energy-efficient lighting systems cannot be developed without photonics. Photonics technologies will contribute to the well-being of the environment and of society.

Safety and security for the citizens of Europe also rely on photonic technologies and solutions. If we increase public security in Europe with the help of innovative photonic applications and components, then we will be addressing a major challenge of the twenty-first century.

These various fields where light plays a major role clearly illustrate the growing importance of photonics in Europe and its impact on our society. If we continue to invest in photonic technologies, we will see still more benefits in the years ahead. The following chapter explains how large-scale, coordinated actions in photonics can tackle some of Europe's most pressing needs. ●○○

.....
*Europe must
focus strongly
on the great
challenges of
our time*
.....

.....
³ Optech Consulting, 2009, data for the photonics market in Europe and the global photonics market

⁴ The Lund Declaration is available at http://www.se2009.eu/polopoly_fs/1.8460/menu/standard/file/lund_declaration_final_version_9_july.pdf



3.0

Photonic solutions to the main challenges facing European society

Fig. 3
The future generation
will rely on energy-
efficient lighting
solutions © Philips



3.1

Challenges to European society

Europe today faces serious challenges. The need to reduce carbon dioxide emissions to combat climate change calls for new energy-efficient technologies and products. An ageing population is demanding better healthcare and earlier diagnosis to prevent illness. As we move towards a knowledge society our communications infrastructure will have to handle much more data while consuming less energy. Globalisation has brought many changes for the better – political, economic and technological – but it has also exposed us to new and ever-changing risks and threats. Ensuring safety and security in society and in essential operations has become a considerable challenge.

Towards a low-carbon economy

According to the 2007 report of the Intergovernmental Panel on Climate Change (IPCC)¹ human activities could raise the mean temperature of the planet by between 1.4 and 5.6 degrees Celsius by the end of the century. The year 2007 marked a turning point for the European Union's climate and energy policy. Europe took the lead in tackling climate change by facing up to the challenge of dependable, sustainable and competitive energy and in turning the European economy into a model for sustainable development in the twenty-first century. Public opinion has shifted decisively towards the imperative of addressing climate change by cutting greenhouse gas emissions and developing our renewable, sustainable energy resources. The European Union committed itself to the following targets.

- Within the Kyoto Protocol the EU committed itself to a reduction of at least 20% in greenhouse gases by 2020, rising to 30% if there is an international agreement committing other developed countries to “comparable emission reductions and economically more advanced developing countries to contributing adequately according to their responsibilities and respective capabilities.”
- A 20% share of renewable sources in EU energy consumption by 2020.²

European research and industry will play an active part in improving energy efficiency and sustainability. The manner in which we produce and consume energy is of crucial importance because energy is closely related to each of the three dimensions of sustainable development – the economy, the environment and social welfare. If energy is to become an integral part of sustainable development, then we need to develop new policies.

Managing the cost of healthcare in an ageing society

Higher life expectancy plus lower fertility rates mean that the age structure of the EU population will change dramatically over the next 50 years. Unless policies change, the current ratio of four working-age people to each pensioner will gradually fall to only two by 2050.³ Public spending on health and long-term care in OECD countries will double in the same period.⁴

Populations are ageing in all the European countries, a trend that is projected to continue until at least the middle of the century. A shrinking working population will generate less income for health and pension systems. While expenditure on long-term care

Public opinion has shifted decisively towards the imperative of addressing climate change

European research and industry will play an active part in improving energy efficiency

will certainly increase, the effects on healthcare expenditure are not so clear. Ageing populations will have different healthcare needs because more people will be affected by cancer, fractured hips, strokes and dementia.⁵ So earlier diagnosis is essential if illness is to be prevented.

The transition towards the knowledge economy

Widespread access to modern information and communication technologies (ICT) is a driving factor behind the EU's efforts to become the world's leading knowledge-based economy. This has been declared in the Lisbon strategy. However, factors such as poverty or a lack of basic ICT skills or inadequate broadband infrastructure still stand in the way of this ambition while effectively barring businesses from markets with high earnings potentials. Addressing this so-called 'digital divide' could become a key element in the European strategy for long-term economic growth.

We may see these challenges as threats but at the same time they offer valuable opportunities to transform European industry for the common good. In the long term, only concerted investment in next-generation technologies will guarantee the prosperity of European society. The key to success is to focus on the strengths we already have. ●○○

Only concerted investment in next-generation technologies will guarantee the prosperity of European society



Fig. 3.1.1 Photonics responds to the societal challenges of Europe © Fotolia

- 1 "Climate Change 2007, the Fourth Assessment Report" of the United Nations Intergovernmental Panel on Climate Change
- 2 "20 20 by 2020 — Europe's climate change opportunity", Communication from the Commission to the European Parliament, the Council, the European Economic and Social Committee and the Committee of the Regions, 2008
- 3 "Investing in the future: an agenda for addressing Europe's Demographic Challenge", Commissioner Joaquin Almunia: Summit "Europe's Looming Demographic Crunch — The Search for New Labour and Welfare Policies", 2008
- 4 "Projecting OECD health and long-term care expenditures: what are the main drivers?", OECD 2006
- 5 "How can health systems respond to population ageing?" Policy brief 10 © World Health Organization 2009 and World Health Organization, on behalf of the European Observatory on Health Systems and Policies 2009

3.2

Photonic solutions as a response

The twenty-first century is the century of the photon

The twenty-first century is the century of the photon. Optical technologies are one of the most dynamic growth markets, both in Europe and worldwide. Photonics can help us respond to the challenges we face in health, energy generation, energy saving and in providing next-generation broadband to the knowledge society. Increasing demands for safety and security will lead to products that make use of photonic technologies.

- Next-generation photovoltaics and solid-state lighting will not only help meet the 2020 climate targets of the European Union, but will also become strong economic growth sectors.
- Optical high-speed broadband networks will drive the knowledge society, opening the door to new services and business opportunities.
- Early diagnosis by means of optical solutions can detect serious illnesses at a very early stage and avoid costly treatment.



Fig. 3.2.1 Photonics helps Europeans communicate faster © Fotolia

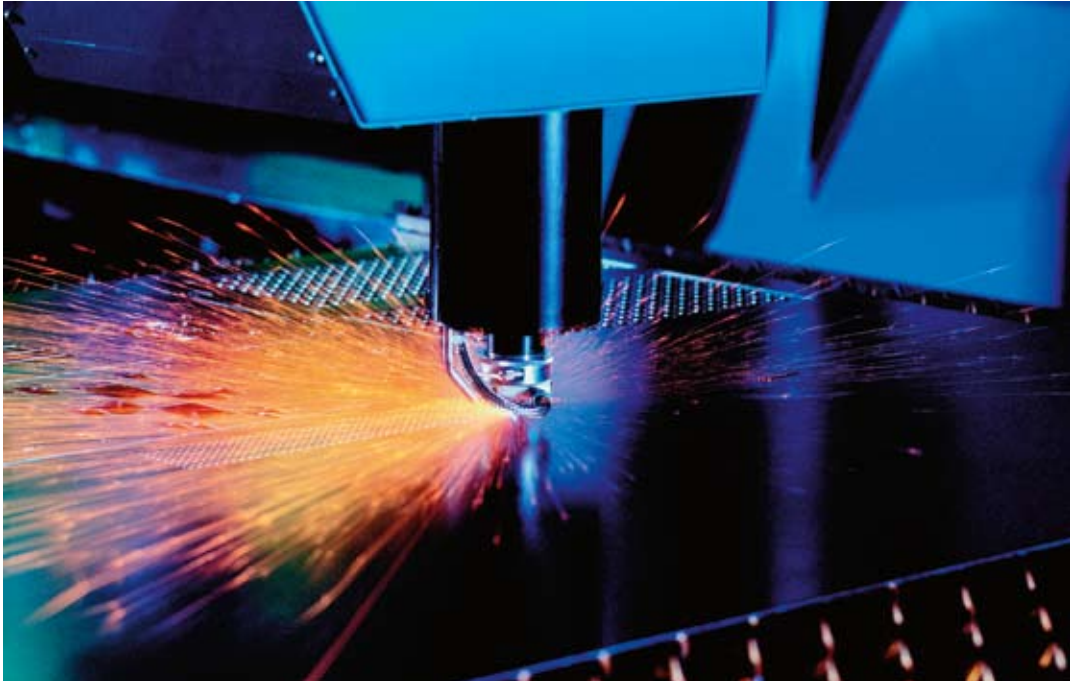

Fig. 3.2.2 The laser has revolutionised manufacturing processes © Rofin-Sinar Laser GmbH

Europe has excellent research institutes which focus on R&D in photonics. Industry, science and government should strengthen their cooperation and adopt public-private partnership models to systematically explore the full potential of photonics in these areas. One such important instrument will be the implementation of large-scale campaigns.

European large-scale action

The need for speed, size and coordination

In many of the competing countries, such as the United States, Japan, South Korea and China, coordinated programmes between government and industry cover the full value chain from innovation to market. They address basic and applied research, standardisation, deployment and market access all at the same time and in a consistent manner.

Deployment is aided by large-scale demonstration actions or by public procurement – the purchase of goods, services and public works by governments and public utilities. Total public procurement in the EU is estimated at about 16% of the Union's GDP but this approach to cutting the time from innovation to deployment has hardly been explored in Europe.

The photonics industry and the research institutes must work with Europe's policy-makers to tie up the loose ends of the innovation system and pool investment to jointly develop next-generation products and get them to market. Without concerted action Europe risks falling behind other parts of the world. We need new thinking in the design of efficient and market-oriented public-private partnerships and programmes. In the twenty-first century size alone is not enough – we also need to move fast. ●○○

We need new thinking in the design of market-oriented public-private partnerships

3.3

Green photonics and its impact on global climate

Green photonics are a key driver for profitable growth

'Green photonics' comprises photonics solutions that generate or conserve energy, cut greenhouse gas emissions, reduce pollution, yield environmentally sustainable outputs or improve public health. Green photonics is a key technology that has the potential to improve the global balance of atmospheric carbon dioxide.

Green photonics covers a broad range of optical technologies and applications: photovoltaic energy generation, highly efficient solid-state lighting (SSL), advanced sensing and instrumentation for environmental monitoring, new energy-efficient communication technologies and clean manufacturing using laser processing. The potential of photonics to cut global emissions of carbon dioxide will be even more crucial in the decades to come.

The economic impact of green photonics

Green photonics is expected to have significant impact in reducing global warming, but at the same time it offers as yet unexploited opportunities for economic growth in Europe. Figure 3.3.1 shows the size of the market for green photonics and predictions for its future development.

Year	Market size
2008	\$28.9 billion
2015	> \$100 billion
2020	\$261 billion
CAGR 2009 – 2020	19.6%

Fig. 3.3.1 Overview of the green photonics market. Source: OIDA, Green photonics market data¹

These predictions show that green photonics will contribute to increases in manufacturing industry volumes and that will further stimulate employment. Europe needs to invest further in green photonics and to guarantee its competitiveness by supporting the next generation of green photonics solutions and applications.

Sustainability in Europe: A solution with green photonics

If we are to save energy and reduce emissions of carbon dioxide we will have to find more efficient ways to produce and consume energy. Optical technologies such as light-emitting diodes (LEDs), organic light-emitting diodes (OLEDs), photovoltaic cells and more power-efficient optical communications all have an important role to play. They contribute, for example, to energy-saving lighting and the efficient use of solar energy.

The two green photonic technologies most likely to have the largest impact in the near future are LEDs for solid-state lighting and photovoltaic cells for solar energy. Photonics is an important part of the green revolution in both energy generation and consumption. ●○○

¹ OIDA, Green Photonics Market Data available at <http://www.oida.org/news/oida-news/2009/377> and Michael Lebby, CEO of OIDA, available at <http://www.photonics.com/Content/ReadArticle.aspx?ArticleID=35146>



Fig. 3.3.2 Organic light-emitting diodes from Novaled: OLEDs – a green and clean technology efficiently providing near-natural light © Novaled AG

Fig. 3.3.3 A pool at Lake Garda, illuminated by green LEDs © Zumtobel



3.4

Energy-efficient lighting

Modern society relies heavily on lighting, whether at home, in the office, in schools and universities, in other public buildings and spaces or on streets and motorways. Thus lighting accounts for a significant share of worldwide energy consumption.

Fig. 3.4.1
The share of lighting
in global energy
consumption. Source:
International Energy
Agency and OSRAM

Global market	Volume
Lighting's share of total primary energy consumption	2.4%
Electricity's share of energy consumption	12.4%
Electricity production for lighting	19% (> 2 600 TWh)

On a global scale, lighting generates 1900 million tonnes of carbon dioxide emissions each year.¹ In Europe, the use of energy-saving light bulbs alone could save 45 billion kWh of electricity and 19 million tonnes of carbon dioxide.²

The key to saving energy

Following a decision in December 2008, the European Commission implemented a ban on the sale of 100-watt conventional incandescent light bulbs from September 1, 2009. All light bulbs of more than 75 watts will be banned in 2010, followed by 60-watt bulbs in 2011 and 40-watt bulbs in 2012. The progressive change in the homes of nearly 500 million citizens by 2016 will have a considerable impact on energy efficiency. Over the coming years about eight billion incandescent light bulbs will be replaced by energy-saving compact fluorescent lamps and by modern, energy-efficient semiconductor alternatives such as LEDs. Using today's technologies it would be technically feasible to save about 30% of the energy now consumed by lighting.

In the future, solid-state light sources — LEDs and OLEDs — may outperform almost all other sources in terms of efficiency and push potential savings up to 50%.³ If solid-state lighting technology is combined with intelligent light management systems, which regulate light output according to ambient lighting conditions or people's presence and activities, another 20% can be saved. Thus advanced solid-state lighting could cut present-day electricity consumption by about 70%.

By realising those solutions, huge benefits can be achieved:

- each year more than €300 billion can be saved on the global energy bill;
- emissions of more than 1000 million tonnes of carbon dioxide can be saved per year on a global level;
- the economy will be boosted by strengthening Europe's industrial position in lamps, luminaires and driver electronics, which together already employ over 150 000 people;
- society at large will profit from greater visual comfort due to superior lighting solutions and from less light pollution through more closely focused light;
- energy-efficient lighting technologies will provide significant individual savings.

In the summer of 2008 an ad hoc advisory group on ICT for energy efficiency was established by the European Commission in order to investigate to what extent different ICT-based technologies could contribute to the goals defined in the Strategic Energy Technology Plan⁴. In the famous Vattenfall⁵ analysis on the abatement costs of carbon reduction, lighting offers the second largest potential for cost saving, close behind improved insulation. Both technologies have reached a stage of development where saving carbon goes hand in hand with saving costs. It is clear that technologies associated with lighting offer the biggest opportunities to save energy in the short run, giving more time for the development of renewable energy sources in order to safeguard Europe's energy independence in the long run.

Greenhouse gas abatement: large positive returns for transition to efficient lighting

The energy savings potential was worked out in the Photonics21 advice to the Commission. Figure 3.4.2 shows four different scenarios for the energy used for illumination purposes over the coming decades.

Figure 3.4.2
Projected overall energy use for lighting in different scenarios

Lighting energy use, PWh per year

Source: Report of the European Commission Ad Hoc Advisory Group for Energy Efficiency

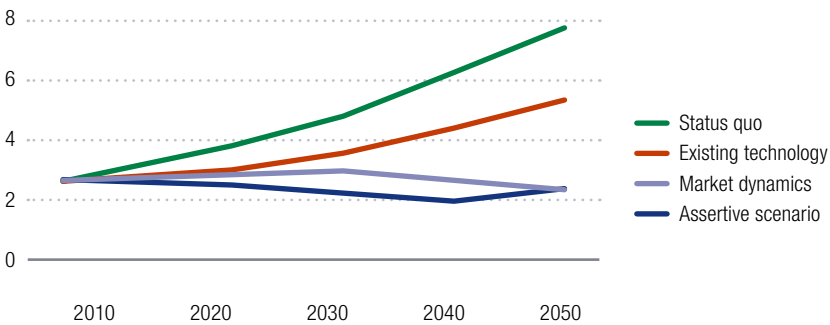

- **Status quo scenario**

This scenario reflects the extrapolation of the present situation based on the forecast of the International Energy Agency (IEA). Nearly 70% of the lighting energy used today, however, goes to lamps for which a better alternative is available.

- **Existing technology scenario**

Switching to the best alternative available with existing technologies would save 30% of the energy needed for illumination with respect to the status quo scenario, but would not reverse the trend towards higher energy needs. The amount of light needed is increasing, however, and hence the luminaire market is steadily growing. Only if we fully

1 International Energy Agency: "Light's labour lost, Policies for Energy Efficient Lighting", (2006).

2 International Energy Agency, European Commission

3 Ad Hoc Advisory Group ICT for Energy, Consultation Group on Lighting & Photonics Technologies (2008)

4 SET Plan. The European Commission has presented a strategic plan to accelerate the development and deployment of cost-effective low carbon technologies. This plan comprises measures relating to planning, implementation, resources and international cooperation in the field of energy technology.

5 See www.vattenfall.com

adopt digital lighting⁶ as depicted by the remaining scenarios will we be able to cope with the increasing demand for lighting over the coming decades without increasing its energy usage.

- **Market dynamics scenario**

In this scenario the present rate of replacement of illumination sources with LEDs and OLEDs is taken into account.

- **Assertive scenario**

In the assertive approach public authorities and industry team up in a joint effort to promote and demonstrate on a large scale what intelligent LED and OLED lighting can do for our economy, and so to speed up market acceptance. Because all electrical lighting will be based on intelligent LED and OLED systems by 2050, energy consumption at that time is expected to be the same as in the market dynamics scenario. But the cumulative energy consumption is significantly less.

The energy savings forecast with intelligent LED systems will result in a global annual saving of 1300 TWh in 2030 and 3000 TWh in 2050. Because we are dealing exclusively with grid-based lighting this can be translated immediately into the annual output of 650 to 1500 medium-sized, 200 MW electrical power stations delivering 2 TWh of energy a year. €190 to €450 billion a year will be saved on our global fossil fuel bill between 2030 and 2050⁷ and can be invested in economic growth instead.

LEDs last much longer than conventional light sources and this will add to the sustainability of this solution. The superior optical performance of SSL compared to gas-discharge lamps will substantially reduce light pollution at night, with a positive impact both on the ecosystem and on each individual. Gas-discharge technology relies to a large extent on the use of mercury. If we adopt LED and OLED technology, no hazardous substances such as mercury will be introduced into our ecosystem.

But one billion people around the world will probably never be connected to the electricity grid. They rely on kerosene to generate light, which is very expensive, produces poor illumination and is hazardous to health. LEDs do not need the high voltages supplied by the grids for their operation. They can be connected directly to low-voltage systems consisting of photovoltaic cells and batteries. In this way good quality, affordable lighting will become available to this large group of people as well.

The social impact of LEDs, and intelligent SSL systems in particular, can best be described as creating greater visual comfort at less cost to the user and the environment. Saving energy always pays for itself over an acceptable period. Providing quality light when and where it is needed creates a much more pleasant environment. Good quality light will improve well-being and personal performance. Users will be able to adapt the light to their personal preferences much easier than with today's lighting technology. SSL lighting also offers new freedom in the design of fixtures, making lighting a thing of beauty in many ways.

Seizing the initiative in these emerging technologies from an early development phase will give Europe an economic advantage. At the same time it will help us respond to the challenges presented by the low-carbon economy and climate change. These economic and social imperatives are well aligned with the technology thrusts described here.

If we look further down the road, OLEDs will become increasingly important and will complement LEDs. The special features of OLEDs make it possible to create highly

*SSL unites
visual comfort,
well-being
and energy
saving*

⁶ This expression refers to intelligent light management.

⁷ Assuming an oil price of 100 euros per barrel.

efficient, homogenous light sources that emit from a large area rather than a point. The technology behind area light sources is still developing, but in the coming years OLED light sources in the form of tiles mounted on walls or ceilings will create large and uniform light-emitting surfaces. OLEDs also lend themselves to innovative lighting applications, such as structured light sources for signage or variable-colour, transparent and flexible sources. For general lighting purposes it is important to improve the efficiency of OLEDs and extend their lifetime. To take advantage of this potential, Europe must develop mass manufacturing equipment and processes.

At present, Europe leads the market for lighting and luminaires (light fixtures). European companies dominate the lighting market and there are more than one thousand luminaire companies. Other countries are also investing heavily in this area and comprehensive governmental programmes – from basic and applied research to market access activities – have started in the past few years. Countries like the United States, China, and South Korea all have strategic and focused solid-state lighting research and deployment programmes. Many countries are investing billions of euros in tackling this area systematically.

As the shift towards semiconductor lighting is already under way, now is the right moment to seize the opportunity to save energy and create jobs in Europe. We need a strategic, pan-European approach to solid-state lighting as none of the EU member states on its own has the critical mass to compete with the massive investments being made abroad. It is therefore urgently necessary to launch a combined and strong effort involving industry, the European Commission and the EU member states to quickly come up with reliable, high-performance LED and OLED technology that looks good while being cost effective and saving energy.

We need a strategic, pan-European approach to solid-state lighting



Fig. 3.4.3 A vision for the future: Transparent OLED windows © OSRAM Opto Semiconductors



Fig. 3.4.4 Energy-efficient lighting concepts contribute to a modern architectural design © OSRAM

European large-scale action

The European SSL Innovation Alliance

The proposed European SSL Innovation Alliance will be a closely defined, large-scale action on solid-state lighting (SSL), covering the entire chain, from research to deployment. It will also address standards and the barriers to widespread uptake of SSL. The aim is to give Europe a cutting edge in the introduction of SSL and to establish solutions, rules and standards. As leader in the traditional lighting sector, Europe should strive to be the first to exploit the advantages of solid-state lighting.

The relevant players in Europe are numerous: from LED manufacturers (and, in future, OLED manufacturers), optical design houses and lens makers, to lamp and luminaire manufacturers including several suppliers of materials and electronics. European industry should cover the whole value chain from materials to the development, definition and production of LED and OLED products for the general lighting market. An active academic network with proven excellence in SSL and lighting in general will support the industrial partners with related research.

One of the goals of this large-scale action is to accelerate the adoption of SSL-based lighting systems and so safeguard these highly-skilled jobs and create new ones. Philips and OSRAM, as global market leaders, along with many lighting and luminaire European companies (mainly SMEs) will benefit, as will the European economy. The proposed alliance also stresses the importance of green photonics where Europe should take the lead. The use of environment-friendly energy sources and the reduction of carbon emissions are the main drivers along with the economic benefits. Citizens will also profit from

Now is the right moment to seize the opportunity to save energy and create jobs in Europe

SSL through lower energy bills and a better living environment with less light pollution at night and more natural-looking artificial lighting during the day.

Benefits will extend beyond the lighting industry itself. Companies in the upstream markets, such as producers of materials and system components, as well as those in the downstream market, including producers of high-end applications and devices employing SSL solutions, will all profit from this action.

Apart from the general lighting market, where the biggest impact is expected, other products and applications will include:

- lighting and illumination systems based on SSL, including automotive lighting;
- architectural lighting;
- off-grid lighting;
- intelligent light management systems to tap the full potential of SSL;
- large area (LED and OLED) displays for outdoor use;
- safety signage;
- digital projectors of all sizes, from pocket-size to high brightness (LED and OLED);
- TV and display backlighting (LED).

Planned projects in the framework of the alliance

The European SSL Innovation Alliance will bring together partners from science and industry, but also users such as architects and lighting designers. The proposed projects will concentrate on:

- R&D on new, advanced and improved SSL devices;
- large-scale demonstrations proving the potential of SSL solutions;
- improvement of SSL lighting quality (spectral uniformity and balance) for future applications within sensitive markets such home and workplace lighting;
- a design competition for products employing SSL;
- European cross-licensing and training programmes to stimulate the replacement of today's lighting by SSL solutions and to share competence between system and lighting designers;
- emphasis on environmental issues related to lighting;
- public relations;
- regulation, standardisation (to ease access to the new technology and to facilitate combining it with existing systems), life-cycle assessment and reliability.

A concerted effort by European industry, the European Commission and member states would result in substantial energy savings. In the long run, 30% of lighting energy can be saved with existing technology and a further 40% by the introduction of new LED technology. LED-based backlights for LCD displays and television sets consume 40% less energy than standard cold cathode fluorescent lamps (CCFL backlights). Strengthened R&D efforts in SSL will clear the way to low-cost, high-quality LEDs. Since consumer acceptance is the key for broad market penetration, complementary actions as described above are needed to efficiently penetrate market introduction barriers. ●○○

Switching to intelligent SSL systems leads to huge electricity savings

3.5

Renewable energy generation

Solar energy and the global energy demand

According to estimates by the World Energy Council, the world's demand for electricity will double within the next forty years. At the same time prices for scarce resources such as oil and natural gas will rise, leading to a global demand for alternative energy sources such as solar energy. Due to the shortage of fossil fuels and increasing environmental pollution from carbon dioxide emissions, the photovoltaic industry will become ever more important. In the coming years, Europe must further support the development of the photovoltaic sector.

According to EPIA a 12% market share of the EU electricity demand for photovoltaics in 2020 is an achievable objective

European goals for 2020

In 2010, 0.5% of the total electricity production in the EU will be generated from solar power. This proportion must rise if solar energy is to contribute to sustainable development. The EU's Renewables Directive aims to achieve the European target of supplying 20% of all energy demand from renewable resources by 2020. According to a recent report published by the European Photonics Industry Association (EPIA)¹ a 12% market share of the EU electricity demand for photovoltaics in 2020 is an achievable objective.



Fig. 3.5.1 Photovoltaics contributes to an energy-efficient future © Fotolia

Europe is asked to achieve three important goals by 2020 and support solar energy and photovoltaics.

- Europe should encourage the development of solar cells to improve their efficiency by 30%.
- European industry should achieve costs below €0.10 per kWh for electricity from industrial scale photovoltaic systems.
- The share of photovoltaic electricity in the EU electricity market should be more than 10%, compared with less than 1% today.

These three objectives in photovoltaics will help the EU meet its ambitious goal of a 20% reduction in carbon dioxide emissions by 2020.

The European photovoltaic sector

Europe is among the world's leading providers in both photovoltaic energy generation and in the production of photovoltaic cells. Today, Europe produces about half of the world's photovoltaic electricity. In 2007, the European market share of the world production of cells was 27% compared to 29% for China and 22% for Japan. This proportion shows strong competition from Asian countries. European companies are currently facing greater international competition especially as Chinese companies expand their solar cell production. The average annual growth rate of the photovoltaic industry is estimated to be 20–30%. However, technology differentiation becomes a top priority for success in a market where the dynamics of supply and demand are changing. Europe will be competitive in future only if it manages to significantly increase efficiency and productivity.

Under the right framework conditions, photovoltaic generation costs could fall by 8% each year² which means, for example, that technological research and deployment could improve efficiency by 30% by 2020. This could halve electricity generation costs every eight years.

Europe is still the most advanced region in the world for photovoltaics. In 2008, more than 1500 large-scale photovoltaic plants were operating in Europe, of which 800 were connected to the electricity grid.³ Forecasts show that Germany, France, Spain and Italy could account for more than 75% of the European market by 2013. The same countries, along with Greece and Portugal, will be the chief contributors to the future growth of the photovoltaic sector.⁴

Employment predictions show the direct positive impact of the photovoltaic sector on the European labour market. Further development of the sector will create jobs throughout Europe. In 2007, about 70 000 people were directly and indirectly employed in the photovoltaic sector within the EU and this number will grow as new photonic solutions are developed and solar cell production expands.



Fig. 3.5.2 The future generation will rely on renewable resources
© Fotolia

Europe will only be competitive in future if it manages to significantly increase efficiency and productivity

1/2 "SET For 2020", Report, EPIA, 2009

3 "PV resources annual review displays development of utility-scale PV power plants: all-time records in capacity and growth", available at <http://www.solarserver.de>

4 "Solar PV Builds Momentum across Europe", available at <http://www.emerging-energy.com>

European large-scale action

Photonic tools for solar excellence

A large-scale action on new photonic tools for photovoltaics offers a unique opportunity to promote R&D and deployment and to help European companies stay at the forefront of technology in solar cell production. This will further maintain and strengthen Europe's strong market position in photovoltaics and support European competitiveness in the global market. The photovoltaic solar cell industry is growing rapidly, but to stay competitive in the longer term we have to lower the cost of each unit of electricity generated. This requires more efficient cells and better productivity.

All the photovoltaic manufacturers are seeking to raise the efficiency of their products and the productivity of their processes. For their next-generation production lines, non-contact processing equipment is considered essential. This prioritises laser-based processing. Figure 3.5.3 lists several steps in the process where lasers could be used for both crystalline-silicon (c-Si) and thin-film (amorphous silicon or chalcogenide compounds) cells.

Crystalline silicon (c-Si) cells	Edge isolation	Selective ablation (openings)
	Laser grooved buried contacts	Wrap-through (emitter, metal)
	Texturing (etch barrier ablation)	Dopant diffusion (selective emitter)
	ID marking	Laser-fired contacts
	Cutting	Singulation (CPV cutting)
	Wafer inspection	Interconnection (module soldering)
	Defect repair	
Thin-film cells	Patterning	Crystallisation
	Border deletion	Pulsed laser deposition
	Glass cutting	Sintering/annealing

Fig. 3.5.3 Laser applications in photovoltaic manufacturing

Only two laser applications are in widespread use today – edge isolation for c-Si and patterning for thin-film panels. Most of the processes in the table are still at the proof-of-concept stage or in laboratory-scale demonstrations. A lot of research has been put into ways to increase efficiency, many of them using lasers, but the record efficiencies attained in laboratories cannot be reproduced on the production line. A consistent, commercial laser production technology is still not available for all the manufacturing steps required.

A successful deployment of those steps requires:

- access to a wide range of laser sources with different wavelengths, pulse widths, repetition rates and power levels;
- expertise on laser processing (and machining) and knowledge on how to transport laser beams and modify beam profiles from laser output to sample including scanning options;
- characterisation of solar cells after laser processing to predict final cell performance in a production environment.

Although several issues have been addressed in R&D projects across Europe, there remains an urgent need for a large-scale holistic approach to pave the way for laser applications in solar cell production. There are two priorities.

First, we need to match the roadmaps of the laser and photovoltaic industries. The demand now is for more compact, more reliable lasers with faster throughput (higher repetition rates). Novel, laser-enabled design concepts require new laser architectures and a sound understanding of mechanisms related to process and materials.

Laser systems will include compact lasers of high average power delivering ultra-short (sub-nanosecond) pulses, as well as improved beam delivery systems to carry the laser light to where it is needed. New concepts for novel laser wavelengths and frequency conversion (green, ultraviolet and deep ultraviolet) and for spatial and longitudinal mode control have to be developed. Novel strategies such as remote and scanner technologies or multiple-beam processing are needed in order to raise productivity.

Second, we need to make more use of automation to cut the time from R&D to production. Such innovations should make full use of the advantages lasers can offer. For example, high-speed robotic systems used in conjunction with high-performance vision systems will shorten cycle times.

R&D activities should be accompanied by demonstration projects and measures to support the qualification of pilot production lines. Market dynamics within the photovoltaic industry drive each of the different thin-film and c-Si cell architectures. Laser processing is a basic prerequisite for high-volume, low-cost manufacturing of thin-film panels. In the production of c-Si cells laser systems allow much thinner silicon wafers to be processed and so drive down the costs of silicon feedstocks. They also raise processing speeds and improve the efficiency of the cells. Thus, laser applications in photovoltaics meet the demand for higher efficiency of solar cells and lower cost per watt.

This large-scale action on new photonic tools for photovoltaics offers a unique opportunity to promote R&D and deployment and help European companies stay at the forefront of technology in solar cell production. It will help maintain and further strengthen Europe's strong market position in the photovoltaic industry and so support European competitiveness, employment and the reliability of the energy supply. ●○○

We need to match the roadmaps of the laser and photovoltaic industry



Fig. 3.5.4
Solar cell production
© BP Solar

3.6

Europe's ageing society

The ageing generation has to play a full part in our society

Populations are ageing in all the developed industrial countries. In 2007, 500 million people, 8% of the world's population, were older than 65 years. This number will rise to one billion, 13% of the world's total, by 2030. One person in every eight will then be considered elderly. People aged 65 and over now make up the fastest-growing segment of the world's population.

This same trend is reflected in Europe. Projections show that by 2050 the number of people in the EU aged 65 or more will grow by 70%. The 80+ age group will grow by 170%.¹ It is important that this ageing generation continues to play a full part in our society.

As older people are more prone to illness and need more long-term nursing care, global spending on healthcare will rise considerably in the coming decades. This will clearly have an effect on future generations, not least as the proportion of people in work and paying taxes will fall as the population ages.

However, the European Commission has estimated that if people could remain healthy as they live longer, the rise in healthcare spending due to ageing would be halved.² Therefore we must support actions and measures that promote health, prevent illness and find solutions for the future healthcare system in Europe.



Fig. 3.6.1 The number of older people in Europe will grow considerably in the coming decades © Fotolia

Healthcare in Europe

Good health and good healthcare are very important factors for European society and each individual. We expect to be protected against illness and disease whether we are at home or at work and while we are travelling. We want to bring up future generations in a healthy environment and demand a safe and hygienic workplace.

The EU health strategy, Together for Health: A Strategic Approach for the EU 2008-2013, was adopted in 2007 and is a strategic framework for work on health at the EU level. According to this strategy, health is a central factor in people's lives and we need to support it by effective policies and activities in member states, both at European and global levels.³

Article 152 of the Amsterdam Treaty of the European Union says that a "high level of human health protection shall be ensured in the definition and implementation of all Community policies and activities". This article shows that public health in Europe is a very significant issue. We can regard "health as the greatest wealth"⁴ which means that a healthy European population is a prerequisite for economic and social prosperity.

New technologies are revolutionising healthcare and methods of predicting, preventing and treating illness. Photonic solutions and applications have an important role to play and can contribute to the future sustainability of health systems in Europe.

Cancer – a major threat to the ageing society

There are 200 different types of cancer, representing a small group of the 30 000 known diseases. Today, colorectal cancer is the second most frequent cause of death from cancer in Europe. It is responsible for more than 10% of all cancer deaths and for 3% of all deaths within the EU.⁵ This form of cancer mainly affects older people – statistics indicate that seven out of ten deaths are in people older than 65 – and is a good example of the close relationship between healthcare and the ageing society. According to the Deutsche Krebshilfe the incidence of cancer in Germany will rise by 50% by 2030. This trend, which is seen worldwide, is caused by the ageing of the population in conjunction with falling birth rates. Age, together with some environmental circumstances such as smoking, is the paramount factor for cancer. Costs of healthcare in European countries are already growing much faster than GDP. This development shows that we have to introduce new photonic solutions and applications for cancer diagnostics and treatment so that Europe will be well prepared for the needs of the ageing society.

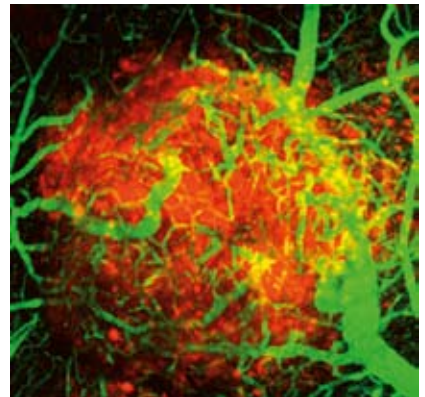

Fig. 3.6.2 Molecular imaging reveals a cancer tumour © Zentrum für Neuropathologie München

1 Eurostat population projections published on the International Day of Older Persons, September 29, 2006

2 "The impact of ageing on public expenditure: projections for the EU25 Member States on pensions, healthcare, long term care, education and unemployment transfers (2004-2050)", Economic Policy Committee and European Commission (DG ECFIN) 2006, European Economy, Special Report No. 1/2006

3/4 Commission of the European Communities, "Together for health: A Strategic Approach for the EU 2008-2013"

5 "Eurostat regional yearbook 2008", available at <http://www.eurostat.org>

Two thirds of all diseases today cannot be treated by tackling their root causes

The current diagnosis of disease

Two thirds of all diseases today, among them dementia and some ophthalmic diseases, cannot be treated by tackling their root causes. This is not only a global but a European challenge. Many diseases can only be diagnosed relatively late in their development, so we need better diagnostic tools and methods to further develop efficient treatments.

Changing patterns of illness call for more preventive medicine and earlier diagnosis. Research in life science to support preventive medicine will contribute to a significant reduction of healthcare costs. The application of photonics in healthcare could reduce costs by as much as 20%.

Photonic solutions help to diagnose severe illness patterns and to cure patients at an early stage. Early diagnosis by photonic technologies and applications will help prevent illness and so have a beneficial effect on patient health, on the healthcare system and on society. As demographic change and the ageing society in Europe push healthcare costs upwards, photonic solutions may help to reduce these costs and to improve quality of life.

European large-scale action

Cancer tissue diagnostics for the twenty-first century

The diagnosis of cancer need not mean that the condition is incurable. In cases when cancer is detected and removed early enough approximately 50-60% of the patients are fully cured, and the earlier cancer is detected, the faster and more effective the treatment can be. Early treatment also saves costs. Unfortunately, we do not have reliable tools and methods for the early detection of many kinds of cancer. The development of such methods and their clinical application is therefore the key to saving millions of lives and, at the same time, avoiding additional strain on the healthcare system. Early detection of cancer can prevent further outbreaks as early diagnosis and treatment can prevent the tumour from spreading to other parts of the body.

Early diagnosis by photonic technologies will help prevent illness

The main challenge for the development of methods for early detection is that malignant tumours, of which cancer is one type, represent a whole class of diseases with manifold causes and mechanisms which affect a multitude of different organs. On the other hand, solutions for one particular kind of cancer may be readily applicable to other kinds. Such a multifaceted problem cannot be tackled by one group or even one country, but demands coordinated cooperation and action at a European level. A large-scale action would enable particular solutions to be developed quickly and then extended to address the wider problem. Such solutions could adapt technologies and methods that already work for certain types of cancer. Fluorescence methods already being used to detect cancer of the bladder, brain, cervix and skin could be adapted for the minimally-invasive examination

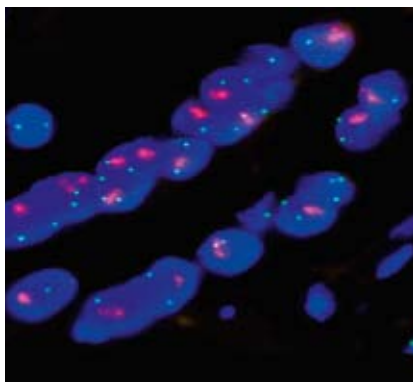

of the colon, lungs and other organs. A further approach could be an appropriate combination of existing methods and technologies, such as digital microscopy with Raman spectroscopy, to gain both morphological and molecular information in concert with automated image and pattern recognition.

The action needs to involve all concerned parties in a close, multidisciplinary collaboration beginning with the medical problem. Physicians, researchers and developers must work more closely together. The medical challenges must be the starting point for

Fig. 3.6.3 Cancer diagnostics improve healthcare in Europe
© Pathologisches Institut der Ludwig Maximilians Universität München



Fig. 3.6.4 The elderly generation should play a full part in our society © Fotolia

the development of methods and tools. This process needs to be coordinated to avoid duplication of effort and to broaden the transfer and exchange of ideas. In many cases completely new methods will not be necessary. An appropriate combination of existing photonic (and even non-photonic) methods could quickly lead to better solutions than the current 'gold standards'. We can expect more precise and faster diagnosis, better forecasts of the likely course of the disease and improved recommendations for treatment. The new techniques should also have the potential to follow-up and control the treatment regimes.

Patients and patient organisations must be involved at all stages in this work. This will help to ensure that the resulting solutions are practical, gentle on the patient and therefore likely to be widely accepted. Once the solutions have matured they will be subject to clinical trials in at least twenty to forty medical centres. Industry must be strongly involved in the development processes alongside the universities, research institutes and hospitals to ensure that these new diagnostic tools are rapidly transformed into marketable products.

At present the time to market (and, therefore, the time to the patient) is much too long. Legislative action at a European level would help ensure the success of this proposed European large-scale action. ●○○

New diagnostic tools should be rapidly transformed into marketable products

3.7

The European information and knowledge society

Information and communication have become pivotal in our society. While the concept of 'information society' is linked to technological innovation, the term 'knowledge society' suggests a social, cultural, economic, political and institutional transformation and a more pluralistic and developmental perspective. The information society is the foundation for the knowledge society. As the technological revolution shows, the information and knowledge society creates new devices that themselves continue the revolution.

For most people the route to the information and knowledge society is through a broadband internet connection. It affects employment, education and health. Broadband supports the expansion of telecommuting which helps workers to balance employment and family life. Broadband technologies also provide easier access to education that stimulates new ways of interactive learning as well as new ways of lifelong learning. Medical services such as telemedicine or the rapid transfer of medical emergency data go hand in hand with the mobility and health of patients as well as demographic changes. Other important applications that rely on ICT include e-mobility¹, e-government agency services and financial services.

Information and communication in Europe

The information and communication market is a dynamic one with short technology cycles, where innovation in telecommunications equipment and by component manufacturers is especially important. More and more digital data is received, stored and distributed by users' mobile devices. The European 'digital and mobile society' often uses mobile TV, internet, video and navigation systems. At the same time, information and services are becoming the most valuable commodities in Europe. Unlimited access to the internet is the most important driver of productivity and competitiveness. Photonic solutions and applications will help develop the European knowledge society by improving the optical network and accelerating global and Europe-wide communication.

The importance of the European digital sector has been increasing since 2005. Europe currently is a global force in advanced information and communication technologies. These technologies account for 50% of the rise in EU productivity over the past four years.² Figure 3.7.1 shows the growing importance of the internet within European society. Europe has made strong progress with regard to the development and availability of online public services. More and more financial and public services are provided via the internet. The development of high-speed broadband creates new markets as well as new jobs and new skills. Europe is the world leader in broadband internet but lags behind Japan and South Korea in the installation of high-speed fibre. To stay competitive in the global market we have to invest in new photonic solutions and applications. Europe should also further foster innovation in new services and content.

Photonic solutions and applications will help develop the European knowledge society

1 E-mobility describes the development of contracts and business processes via the internet. Operations can be organised in the virtual space with the help of machine-to-machine communication detached from the mobility of a person.

2 European Commission's "Digital Competitiveness Report", available at http://ec.europa.eu/information_society/newsroom/ct/itemlongdetail.cfm?item_id=5146

Activities	Use
Use of broadband internet	114 million subscribers
Interactive activities such as communication and online financial services	80% of regular internet users
Use of eGovernment services	1/3 of European citizens and 70% of businesses

Fig. 3.7.1 Use of the internet in Europe. Source: European Commission's Digital Competitiveness Report.

The internet offers enormous opportunities for future economic growth but it will require development of the next-generation information infrastructure. Information technologies tend to be associated with productivity improvements, so the exploitation of the latest technologies will give European industries a competitive advantage and so protect and create jobs.

But information and communication technology also uses large amounts of energy – the internet is said to consume as much energy as international air traffic. Europe has a strong responsibility to promote energy efficiency in information and communication by way of photonic technologies and applications.

Photonics for communication

Today, the major highways of communication and information flow are optical. The data rates of the internet are rising with advances in lasers, optical fibres and optical coding technologies. Bringing the benefits of broadband communications to European citizens is both the challenge and the reward for the next generation of photonic systems. Computers and telephones may be connected to the network by cable or wirelessly, but a short distance away the signals will certainly be optical. In the near future many of these 'short' distances will become 'zero' distances, as optical networks become

Today, the major highways of communication and information flow are optical



Fig. 3.7.2 Made by light – the internet relies on optical fibres © Fotolia



Fig. 3.7.3 Information & communication technology connects the globe © Fotolia

*The internet,
as the biggest
machine in
the world,
will become
a photonic
engine*

embedded in our homes and places of work as well as in our equipment. We all now depend on this infrastructure for our communication, business and entertainment needs and look forward to the next stages of its evolution, whether they be in new services, enhanced connectivity, lower cost or 'infotainment'. This evolution is essential to a sustainable future. Genuine broadband communications, available everywhere, will continue to revolutionise all aspects of society, relieving pressure on areas as diverse as energy and transport, particularly as communication and visualisation technologies overcome barriers of distance and geography.

As the World Wide Web grows by the day, optical solutions for communication will become more important and the internet, as the biggest machine in the world, will become a photonic engine. In 2020, the internet will be mainly used with mobile appliances and will link mobile phones, PCs, domestic appliances, machines and vehicles.

The digital divide in Europe

The term 'digital divide' describes the gap between people with effective access to the internet, especially broadband access, and those with very limited or no access. Part of the divide is due to the physical lack of broadband infrastructure in some areas, but in Europe it is primarily a social divide affecting older and less educated people who lack ICT skills. It is also a knowledge divide, as people are cut off from sources of information and learning.

Although all sections of society are making more use of ICT, the digital divide has still not been bridged. Therefore, Europe should, for example, encourage the teaching of computing and internet use to every child and thus foster the widespread use of ICT.

European large-scale action

The digital village

Over the last few years EU projects have created test-beds to evaluate different technologies for next-generation networks and how services might be delivered. Research has also shown us how people behave in a connected world.

As a European large-scale action we propose to create 'digital villages' where residents can enjoy very high-speed internet access at rates of 10 Gb/s and more. It will give companies the chance to provide the necessary technology to a representative cross-section of an urban population. The action will test the technical requirements as well as consumer acceptance of upcoming complex Web 2.0 applications and probably even semantic Web 3.0 applications. Business models will be evaluated well before the wider market for high-speed internet comes into existence.

On the technical side, all the different components, modules and systems could be tested. Each village would use a different network topology and architecture so that the installation and maintenance costs, energy efficiency, and so on, can be compared. The action will also examine the energy-saving potential of different architectures for next-generation networks. As it is not useful to have different topologies within the same network, we recommend that a sufficient number of digital villages be equipped with such complementary technologies, preferably at least one in each participating country.

But the digital villages will be about more than technology. They will be a proving ground for future high-speed content services that simply cannot run under the limited conditions of current networks. Service providers could test advanced applications in a realistic setting and gain valuable information about customer acceptance, reliability, security, privacy and cost as well as the practical limitations.

Some examples of highly demanding applications are:

- facility management;
- HDTV, quadraphonic HDTV and 3D-quadHDTV over the internet;
- 3D-HD video conferencing;
- remote real-time teamwork on complex IT content and IT projects;
- multi-channel video surveillance over the internet;
- personalised graphic content for interactive virtual reality (gaming);
- live streaming of theatre, concerts and sports in HD.

This technology-based R&D test-bed should work closely with the EU-sponsored 'Future Internet' public-private partnership which is developing next-generation internet content and services. Such a joint approach could deliver valuable synergy effects, shaping the myriad possibilities the future internet will offer to businesses and society as a whole. Completely new business models and services may emerge to bring Europe's knowledge society another step closer to reality. ●○○

We propose to create "digital villages" where residents can enjoy very high-speed internet access

A joint approach will create valuable synergies

3.8

Safety and security

Safety and security include all measures to counter collective and individual risks. While ‘security’ relates to taking preventive measures against physical and intentional attacks, ‘safety’ aims to reduce possible dangers from the operation of systems and machinery or from environmental hazards.

Photonic applications for the safety of European society

People want to feel secure when they go into public buildings, airports, railway stations and other public places. Therefore, a primary focus must be on the safety of products, systems, buildings and infrastructures. Sensors and measuring devices play an important role as they enable us to detect dangers at a very early stage. Information and communications technology contributes to collecting and processing data to avoid dangers. The technological challenge is to develop photonic solutions and applications and to test the reliability of components related to safety.

In road transport, applications such as intelligent driver-assistance systems and night vision systems will improve safety for all road users. Driver-assistance systems in cars rely on photonic sensors to help avoid driving errors. If we further develop these photonic technologies, our roads will be even safer in future.

The detection of unauthorised goods at airports and international borders is another important issue for public safety. Innovative photonic applications can help make such inspections more efficient. Biometric technologies, which also use photonics, can enhance safety and security at international borders.



Fig. 3.8.1 Intelligent driver-assistance systems © BMW



Fig. 3.8.2
Photonics increases security at European airports © Fotolia

We must also improve the general reliability of products, systems, buildings and infrastructures with the support of photonic solutions and applications. They also help to minimise the risk of human error in the operation of technical systems.

All these diverse fields of application show that future photonic technologies and solutions will help make Europe a safer place.

Security at the borders

As the countries of the European Union take down their internal borders, the threats of terrorism, smuggling, trafficking and illegal immigration all require strengthening of the external borders. Ports and airports are relatively easy to monitor, but land borders remain vulnerable.

The days of minefields and electric fences in Europe have passed, but many states are turning to various types of surveillance technology to watch borders, especially in sparsely populated areas. Photonics has a key role to play here as several of the sensors used, especially video cameras, incorporate optical and infrared technologies.

This is an area in which European firms have technical expertise and the market is potentially huge, but growth is hampered by the high costs of installing and operating these systems. Border surveillance systems are very expensive, around €115 000 a kilometre for the equipment alone, and at present can only be contemplated by wealthy states. Most of the capital cost, especially on long borders, lies in the expense of installing secure cabling to connect the various sensors to each other and to the surveillance centre. The equipment costs are relatively small. Most of the running costs are in the wages of operators paid to watch screens and monitor instruments.

Clearly there is a need for a cheaper alternative. One approach is to use modern wireless sensor technology to design surveillance systems that do not need physical cabling. The other is to introduce much more automation to detect intrusions so that operators' time can be spent on the more productive tasks of investigating and dealing with such incidents.

Both approaches point to surveillance networks made up of self-contained, intelligent sensors that organise themselves into a network and communicate wirelessly. Photonics can contribute to the design of the sensors themselves, their communications and their sources of power.

Real-life applications using photonic sensor-based networks are still rare. While some have already been implemented, many others are still in the laboratory. We need a

Photonics can contribute to the design of the sensors themselves, their communications and their sources of power

coordinated, large-scale action to bring this technology to fruition at prices the market will accept. The benefits to Europe will not only be in more secure borders, but in the wider market for video surveillance systems of all kinds.

Figure 3.8.3 Initialisation of a virtuous circle

Source: Sagem

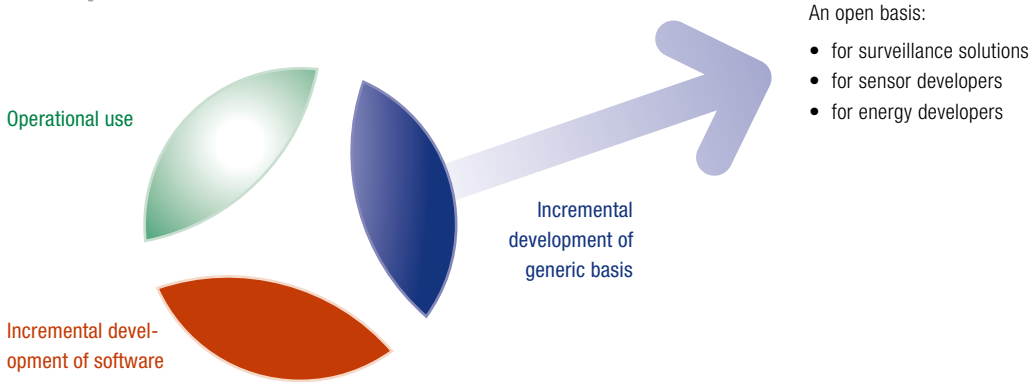

European large-scale action

Sensor security network

Europe is the world's leading provider of surveillance cameras with a market share of more than €1 billion. One response to pressure to reduce costs would be to give cameras more added value in future surveillance systems by integrating other functions.

Development of an open wireless network (both data and power) will bring a radical breakthrough in video surveillance, border surveillance and many other security and safety applications where installation engineering is more expensive than the technology.

The development of such a network will support and be supported by the development of high-performance and smart photonic sensors. It is currently the dream of many integrators of surveillance systems to have a camera that can be placed where the user wants and that will cooperate with other equipment to detect threats or abnormal events. To ensure that such a camera will be compatible with other components, open standards will be required at several levels:

- at the level of the sensor (outside this action);
- at the level of the equipment, where an open architecture has to be considered. The architecture and standards will have to cope not only with the sensors but also with computation capability, communication and energy management (low energy consumption, energy storage and scavenging of energy from the environment);
- at the level of application software to be deployed on the network. Only a first demonstration application will be developed in this action.

This large-scale action can be regarded as an attempt to start a virtuous circle (Figure 3.8.3) similar to the one that has been so successful involving electronic components, microcomputers and software.

An open wireless network will bring radical breakthroughs in video and border surveillance

The main challenge of the wireless sensor network lies in energy management at each sensor node. It may be overcome through generating and storing electrical energy in each node and by drastically reducing energy consumption. Energy generation may come from various sources such as solar and wind but will always remain limited and irregular. Energy consumption by the sensor node has three main origins.

- The sensors themselves: This is a challenge for sensor research.
- Communication: Energy used in communication can be reduced and one challenge of this action will be to select and develop the best technological solutions. But any energy savings will always be limited by the amount of information to be exchanged.
- Computing: Another challenge is therefore to use low-power local computation to reduce the need to transmit data between the nodes of the network. This will require embedded intelligence tailored to the application.

Figure 3.8.4 shows how these various challenges depend on each other. It indicates that an integrated but open approach to the problem is essential.

Figure 3.8.4 Challenges in the development of a sensor security network

Source: Sagem

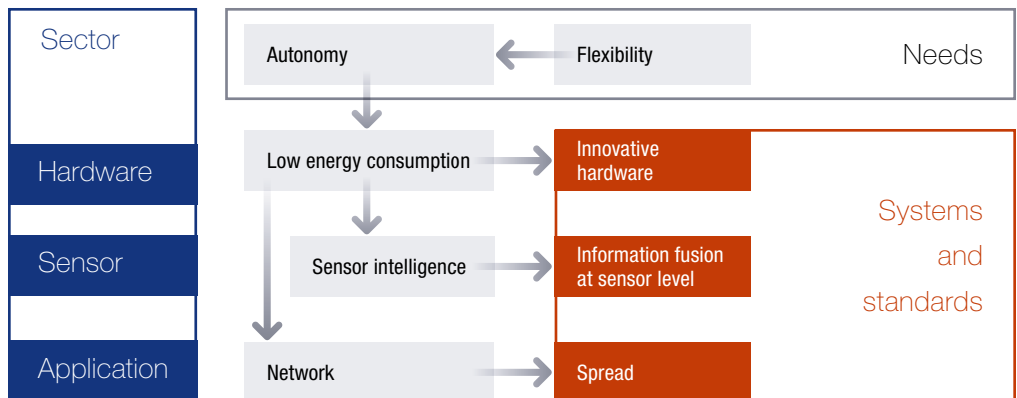

The output of the action will be:

- architecture for a basic wireless sensor node and its standards;
- design and demonstration of a first batch of sensor nodes;
- demonstration of a first wireless video surveillance system.

Partners in the action will be:

- end users to drive the first application;
- video surveillance integrators to drive technical needs and standards and integrate the demonstration;
- research centres to work on embedded intelligence;
- industries to define the architecture, design and build demonstration equipment;
- sensor providers (including photonic sensors) and research centres to provide leading edge sensors. ●○○



4.0

Research strategy for boosting the European economy

Fig. 4 Information
and communication
technology © IMEC

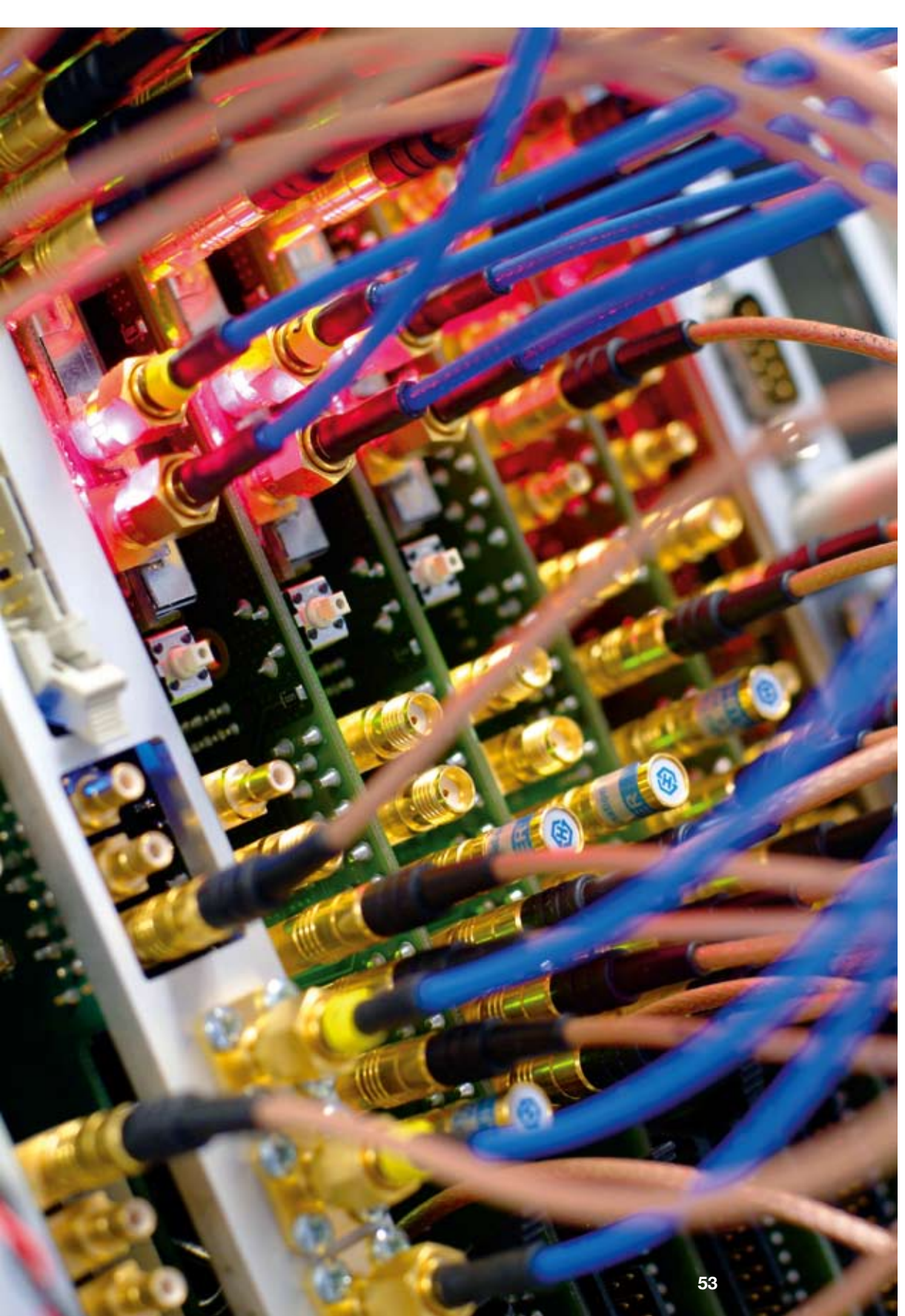

4.1

Information and communication

4.1.1

Revitalising the European economy – Photonics21 information and communication strategy

Over the last five years the information age has changed the way many people live their lives. Young people are now on the third or fourth generation of mobile phone technology, have progressed through text messages, instant messaging platforms such as MSN, to personal web space offered by Myspace and on to social networking sites such as Facebook and Bebo. Sites like LinkedIn and Plaxo are now used by many communities of professional people to network, stay in touch with former colleagues and find new jobs. Many 'connected' people will have access to many gigabytes of online storage, carry a feature phone with processing power equivalent to mainframe computers of 20 years ago and have gigabytes of storage on their person in the form of USB memory devices and phone memory.

Network access is now considered to be one of our human rights

In addition to the benefits to our social lives we are starting to see great improvements in healthcare, government and education through increased web access. These aspects of e-health and e-government will have longer-term benefits as the reliability and pervasiveness of ICT increases.

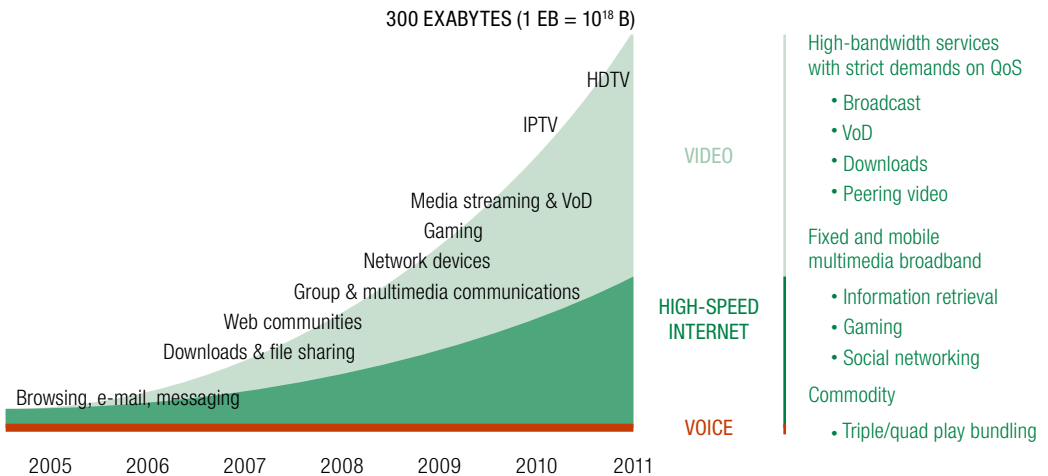

Fig. 4.1.1 Fibre will be a key technology for Next Generation Broadband Deployment © Fraunhofer Heinrich Hertz Institute

Figure 4.1.2 The changing shape of networks – what the future might look like

IPTV forecast growth by 2011: 160 million terabytes pa (based on > 50 million subscribers; ~5 Mbit/s per user; 4 hours/day)

Source: Ericsson



All these factors have helped to make us the most connected and informed society ever. We see instantly pictures and video from almost anywhere in the world, wherever there is mobile phone and internet access. Turning off access to these services is seen as the act of a repressive regime and so network access is now considered to be one of our basic human rights. The importance of mobile technology should not be underestimated in assessing the growth of the communications sector. Whereas the penetration of landline telephony has remained constant over the last ten years, at 47 lines per 100 residents in the EU-27, the number of mobile phone subscriptions has risen from 12 to 106 per 100 residents. In other words there are now more mobile phones than people.

Access to web-based services, including mobile-based services, and the speed and quality of those connections can have an important bearing on the ability of people and communities to be competitive. Areas with poor broadband can be seen as disadvantaged compared to areas with high-quality services, and ultimately as less productive.

Photonics is the link between all of these developments and the underlying communications networks. European institutions and companies have a key role to play in the photonics industry.

All of the above services and communication tools are leading to a continued growth in network traffic of around 40-50% (compound annual growth rate). This growth will be further strengthened in future by novel broadband services (Figure 4.1.2).

The amount of data now being stored (and so available for access via the internet) is approaching 500 billion gigabytes, which is equivalent to two top-of-the-range iPods for every person on the planet.

From all of this frenetic activity come the drivers to build faster, more dynamic networks to access this data, optical networks which are transparent to light throughout, lower-power solutions to reduce the carbon footprint of the internet, and cheaper components and systems to extend these services to everyone.

Access to web-based services contributes to the competitiveness of people and communities

Figure 4.1.3 Worldwide telecoms market by region

Revenue in billions of USD Sources: TIA, OIDA, OIDA members, IOA members and EPIC

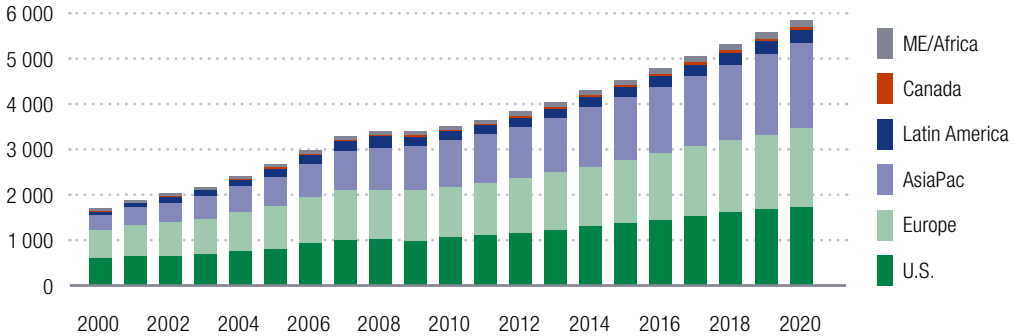

4.1.2

Market overview, main drivers and challenges

Over the last thirty years the use of optical components has grown to the point that the global telecommunications market has come to depend on this key technology to link all its backbone services and also to link into the access network. The next step has already started, with the fibre network being taken to the home, the office or at least to the end of the street with the various options of FTTx (fibre to the curb, home, and so on). Because of this dependence on fibre, optical components and optical systems, photonics is considered an enabling technology for the global communications market. In this section we examine this market and the individual segments for fibre, components and systems in the context of a European vision of maintaining a leading position as both suppliers and users of this technology.

Photonics is considered an enabling technology for the global communication market

The worldwide telecoms market reached \$3.4 trillion in 2008, a growth of 3.2% over 2007 (Figure 4.1.3). The projected growth profile shows this market expanding to nearly \$6 trillion by 2020.

Figure 4.1.4 Global optical equipment market, 2000 – 2020

Revenues in billions of USD

Sources: KMI, Infonetics Research, Ovum-RHK, OIDA member companies, TIA, IDC, CIR, Gartner, Dell’Oro, Avenis, Prudential Equity, OIDA estimates

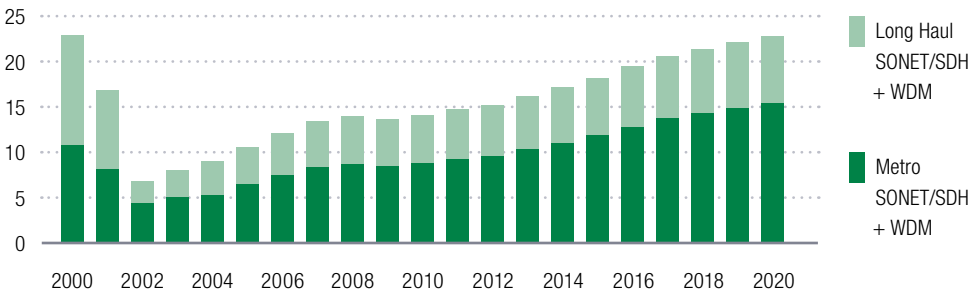

The leverage provided by the optical network equipment and components industry is very large and supports the overall telecom services market. The European market is following the overall trend and is expected to exceed \$1.6 trillion by 2020.

Optical communications equipment

The global market for optical networking equipment is continuing to grow in line with the revenue for the telecoms market as a whole. There was a reduction in revenue following the 2001-2002 slowdown and a recent reduction in growth due to the economic downturn and crisis during 2008-2009. However, growth trends are projected to follow the growth in the overall telecom market (Figure 4.1.4).

The market for optical networking equipment is currently of the order of \$14 billion and is projected to continue to grow to over \$20 billion by 2020.

Figure 4.1.5 Components for datacom and telecom, 2000 – 2020

Revenues in billions of USD

Sources: OIDA member companies, KMI, Ovum-RHK, Laser Focus World, LightCounting, iSuppli, TIA, IDC, CIR, Gartner, Dell’Oro, PIDA, OITDA, OIDA estimates Courtesy of OIDA & EPIC

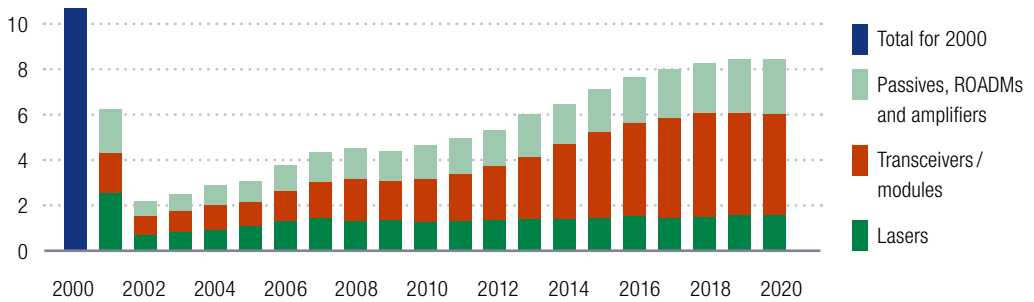

Optical components

The explosion in internet growth and the expansion in network build in the late 1990s caused exponential growth in component sales, which then dropped dramatically during the dot-com bust of 2001-2002 (Figure 4.1.5). However, this can now be seen as the start of the recovery process and subsequent development work has focused on reducing costs and moving toward volume production, something that was not always present in previous development activity.

The expansion of the high-speed communications market has provided many opportunities for development of associated component technologies. This has benefited the European photonics industry (Figure 4.1.6).

Market leverage

The vitally important worldwide telecoms industry is underpinned by the optical network equipment and optical component industries on which it depends. Whilst the global market estimates in Figure 4.1.7 are conservative, and subject to some 10% variation between analysts, they nevertheless indicate the relative sizes of these market segments. They demonstrate the immense leverage provided by the underlying optical equipment and component markets.

Fig. 4.1.6

Automated on-wafer testing of tuneable integrated laser Mach-Zehnder modulator chips (T-ILMZ) for 10 Gb/s applications © Oclaro

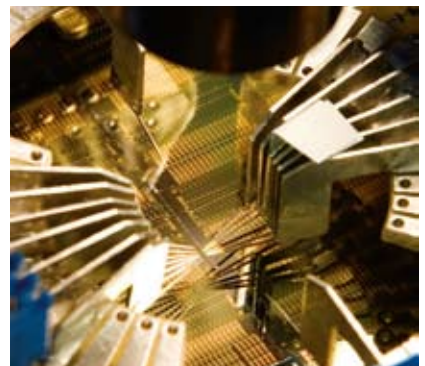

Overall telecom market 2008	\$3 400 billion
Optical network equipment market 2008	\$14 billion
Optical component market	\$4 billion

Fig. 4.1.7 World telecom, optical equipment and components market
Source: OIDA Global Optoelectronics Industry Market Report and Forecast 2009

These figures are relatively conservative and have been subject to some harmonisation because of the analysis by OIDA (Optical Industry Development Association). Some analysts are quoting figures as much as 10% higher, but nevertheless it does highlight the importance of these market segments both in the EU and in worldwide markets.

4.1.3 Europe's position

The financial crisis of 2008-2009 may have slightly reduced expenditures on network builds, but the forecast from analysts such as Infonetics is that this market will continue to grow at 8% CAGR from 2010. Many of the major companies active in optical communications are based in the EU or have extensive development activities here.

The telecom market in Europe is very strong and telecoms are a major employer with over a million people on their payrolls. This figure has remained between 1.1 and 1.0 million for the past twelve years.

Figure 4.1.8 Index of turnover for telecom services compared with industry as a whole

Source: Eurostat (STS)

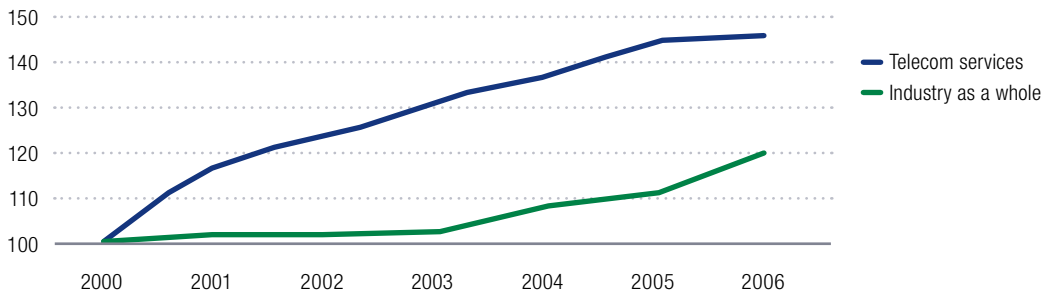

Figures from Eurostat (Figure 4.1.8) indicate that the index of turnover for telecom services in the EU-27 member states showed uninterrupted growth during the period 2000-2006 despite the total industry index rising much more slowly – with almost zero growth for 2001-2003. Much of this expansion has been driven by the growth in the mobile sector.

Arising from this continuous growth in network capacity is an opportunity to coordinate and optimise the use of different technologies – no single technology will have a monopoly or be seen as the right solution in all cases.

The telecom market in Europe is very strong

Europe has very strong leadership in communications technologies. Within Europe there are:

- network operators with world-wide presence;
- major system houses which are European or maintain strong European presence and are technology leaders (mobile and landline);

- large numbers of component houses – SME suppliers to large global players;
- many direct and indirect employment opportunities for European workers.

Telecoms are a major employer with over a million people on their payrolls

The worldwide optical network hardware market in 2008 was \$15 billion (OIDA, Infonetics).

- EU companies or companies with significant EU operations have 45% of that market, worth \$7 billion.
- Sales in Europe were \$2.3 billion and exports came to \$5 billion.

Figure 4.1.9 Broadband growth in OECD countries, 2003 – 2008

Millions of subscribers Source: OECD

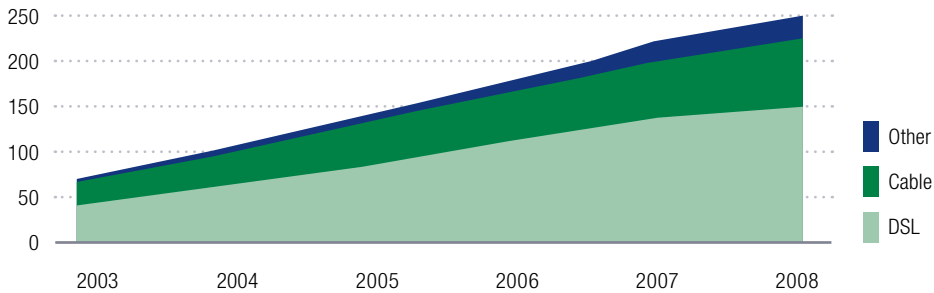

Ultra-fast broadband as a driver for growth

Broadband connection to each dwelling is becoming commonplace in most countries. The number of broadband subscribers in the OECD countries increased by 14%, from 221 million in June 2007 to 251 million in June 2008 (Figure 4.1.9). Broadband penetration rates rose from 18.6 to 21.3 subscriptions per 100 residents in the same period. Over the past decade these connections to the final users have shown a constant increase in performance, with 'fibre to the home' (FTTH) making even higher speeds possible. Speeds of hundreds of Mb/s per user can reasonably be achieved in the foreseeable future, backed up by standards such as Gigabit Passive Optical Network (GPON). FTTH is now widely deployed in countries like Japan and Korea, while in Europe and in the U.S. several companies are developing detailed commercial plans for mass deployment of FTTH. It is thus possible to envisage a scenario in which a large number of users will be offered a very high-performance connection directly to their homes.

Consequently, new high data rate services such as TV programmes or video on demand over xDSL are being made available to the end users and are already a commercial success. New mass storage devices such as media renderers and servers are on the market and promise to make the digital experience even more exciting, for instance with high-definition television (HDTV) and 3-D television. Use of gigabyte mass storage devices in homes is increasing. All these home devices offer not only demodulation of digital broadcast programmes and access to remote services by operators' networks, but also high connectivity to terminal devices such as TVs, home cinema or PCs.

Home networking is therefore booming, while progress in mobile communications helps to extend the experience of multimedia services outside homes. This triggers major changes in the communication networks, from access to core, both in terrestrial and submarine networks, where photonics has played a key role and will continue to do so.

In Europe several companies are developing detailed commercial plans for mass deployment of fibre to the home

Research on behalf of the FTTH Council Europe reached the following findings:

- European broadband speeds are rising at more than 50% a year;
- high-end broadband usage is growing at 20% a year;
- FTTH broadband homes in Europe drive three times more traffic than ADSL.

Since their introduction thirty years ago, photonics technologies have greatly contributed to the massive development of communication networks. It is highly likely that they will underpin most of the network revolutions to come, as unrivalled cost-efficient and power-efficient enablers of new applications that need a lot of bandwidth. Rather than gradual and incremental steps, the rapid pace of development in photonics will continue to lead to the radical increases in network capacity and performance that are necessary to support innovative applications.

4.1.4

Drivers for photonics in communications

An analysis of the market forces which drive the use of photonics suggests that four challenges need to be considered:

- making networks more transparent;
- making networks more dynamic;
- making networks faster;
- making networks greener.

These paths correspond to four market drivers that push simultaneously but that cannot all be satisfied at the same time (Figure 4.1.10). It is therefore important that European industry benefits from research along all four paths in order to preserve its leadership.

The overarching challenge is to make networks affordable over the long run, by dramatically reducing the overall cost per digital bit.

Figure 4.1.10 Technology trends in photonics communications

Scaling the network in capacity and driving down the cost per managed bit

Source: Photonics21, Work Group 1

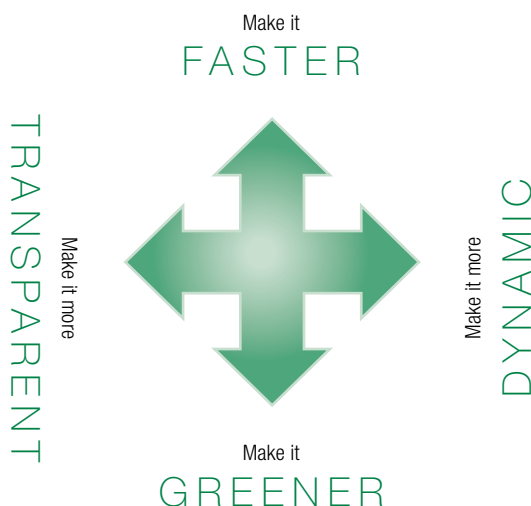

There are other challenges in photonics which are not included here. Security, for example, is important. Although techniques such as quantum cryptography can be employed at the photonics layer, it is the end-to-end security criteria that must be considered. Hence the security level could be increased by using more secure encryption algorithms at the IP (internet protocol) transport layer.

More transparent optical networks

Today's optical transport networks are mainly opaque; they consist of electronic nodes connected by point-to-point WDM (wave division multiplex) links and many optical-electrical conversions from transport to access networks. The potential of photonics technologies to manipulate light by themselves remains largely unexploited. Increasing optical transparency (as opposed to opacity) means removing these conversions as much as possible by using optical switching and bypassing within the nodes. It will benefit both the transport networks, and the access networks, by allowing several bit rates, several modulation formats, and several radio standards to travel across the same generic fibre infrastructure. In particular, transparency will make possible cost-effective convergence of some networks such as radio with fixed access networks, or metropolitan and access networks.

The ongoing introduction of transparency through optical cross-connects based on wavelength selective switches has already removed some limitations on the development of network capacity. In the ideal scenario, an optical data stream enters the network through the input node, might travel across several intermediate nodes, and reaches its destination node without conversion to electronics along the route. Numerous challenges remain to be solved along the path to creating fully meshed, optically transparent networks or subnetworks (also referred to as 'islands').

The potential of photonics technologies to manipulate light by themselves remains largely unexploited



Fig. 4.1.11 Fibre connections in a street cabinet © François Maréchal for France Télécom Orange



Fig. 4.1.12 Fibre connections in a street cabinet © François Maréchal for France Télécom Orange

For example, longer distances will need to be bridged across a greater variety of fibre types than we see today. This will require novel link designs with appropriate dispersion maps to mitigate the affects of impairments in the fibre. All the performance estimators – which are already obsolete – will need to be reassessed. Interactions between signals at various bit rates, travelling across a variety of fibre types will cause new propagation impairments (primarily nonlinear effects) that have to be characterised and contained. The accurate assessment of the distortions stemming from transparent nodes, such as crosstalk or filtering, will need to be included in this picture as well. Coherent detection and massive digital signal processing may help to contain these spurious effects and will deserve particular research attention. The all-optical processing techniques for signal regeneration (preferably of all the wavelength-multiplexed signals at once) or for wavelength conversion are also promising. They could not only help to further extend transparency, but also to bring about wavelength agility (the ability to rapidly change wavelength) and, hence, further save on the number of terminals.

Transparent networks will be able to handle many different types of optical signals

The requirement for more transparency also applies to optical access networks and home networks for one simple reason: transparent networks will be able to handle many different types of optical signals and so cope with all types of traffic in a cost-efficient and energy-efficient way.

Radio-over-fibre techniques, for example, will be key for more transparency in optical access and home networks, leading to convergence of fixed and mobile networks. Long-reach optical access networks (up to 100 kilometres) will allow convergence of metropolitan and access networks, with WDM and cheap optical amplification as a common denominator and 'colourless' customer modules (which do not have remotely configurable tunable components) as a prerequisite. This trend towards more transparency may largely rely on the use of wavelength or subcarrier multiplexing techniques, or both, which can be combined with transparent optical or radio-frequency processing,

alleviating the need to perform digital processing in all parts of the network. Hence, the convergence of metropolitan and access networks could be eased if the aggregation and distribution of signals were to be performed by optical means. Similarly, the convergence of home and access networks would benefit from the introduction of optically transparent home gateways, which remain to be developed. Transparency has the additional advantage of contributing to more energy-efficient networking without decreasing flexibility and agility. Bit for bit, optical transparency will save both money and energy.

More dynamic optical networks

Increasing competition in leased lines and virtual private network (VPN) services strongly encourages operators to provide connections more quickly, or even to allow customer-controlled switched connections at the transport network level. The dynamicity of the optical network is thus related to the possibility of the network automatically and dynamically controlling and managing connections. This could be for protection, or to restore connections in the event of equipment failure, for traffic engineering purposes, or at the customer's request. In the longer term, a truly agile network will require self-learning and auto-discovery of the available resources, making site visits unnecessary.

It will thus pave the way towards truly dynamic optical circuit switching or even optical flow switching (switching very large bursts of packets). The introduction of optical cross-connects is one of the first requirements for dynamicity in the transport network. But dynamicity also requires control software (or plane) for the network. In each node, it should drive the configuration of the optical cross-connects (which wavelength from an input fibre goes to which output fibre) but also force electronic regeneration of a given wavelength that cannot be sent transparently all the way to its destination.

This software has to be 'impairment-aware', that is, aware of the viability of all optical paths before establishing connections: this is, by itself, a real challenge. In the routing process for optical channels, the control plane will also have to take account of energy consumption, thus allowing 'energy-aware' optical networking. To be accurate, it needs to be fed with the parameters of photonic components, possibly from active monitoring, and should rely on dedicated, fast routing algorithms.

The need for dynamicity can be partly addressed by remote wavelength management, thanks to cross-connects. However, other approaches deserve to be investigated to complement this method or to improve upon it. The most promising consist of automatically varying the bit rate per wavelength, continuously or incrementally, or varying wavelength spacing. Dynamicity can also be achieved by adding in or dropping sub-bands from a multicarrier signal, such as an orthogonal frequency division multiplexed (OFDM) signal. All these approaches deserve deep investigation to assess their potential. Other strategies rely on optical switching with much finer granularity than the optical wavelength channel, whether at burst or packet level. These optical burst or packet switching techniques allow traffic coming from access networks to be aggregated efficiently, and will first spread into metropolitan networks and then into backbone networks. In particular, they will be the cornerstone of convergent metropolitan and access networks.

The need for dynamicity will also be the key to future optical access networks able to provide on-demand broadband access connections with adjustable bit rates to end users. Variable bit rate transmitters and receivers will be one approach for this optical access network agility. Agile multiplexing and multiple access schemes will also be developed and tend towards fully wavelength-agile optical access networks. These advanced schemes will be combined with dynamic bandwidth allocation mechanisms based on time, wavelength, or even subcarrier. In particular, agility provided by multicarrier, multiple access techniques (such as OFDMA — orthogonal frequency division multiple access) is

The dynamicity of the optical network contributes to automatically controlling and managing connections

Future optical access networks will be able to provide on-demand broadband access connections

a promising solution for future generations of passive optical networks. In the longer term, optical burst or packet switching is considered a solution for convergent access and metropolitan networks, opening the way to end-to-end all-optical switching in the entire network.

Future use of home area networks will also require a high level of dynamicity. As home broadband and digital storage devices become more common, it will be possible to transfer content at high data rates either from remote servers or between devices distributed throughout the home. This will require agile, multi-format optical home networks based on multipoint-to-multipoint topologies. These advanced architectures will largely benefit from wavelength division multiplexing and subcarrier multiplexing techniques, so as to easily manage multiple access to the network as well as various formats and services including data, video and wireless.

Faster optical networks

Relentless demand for capacity is driving data rates and the need for faster optical networks. To make possible the next phase of network evolution it is necessary to develop system, subsystem and component technologies to deliver truly cost-effective transport at 40 Gb/s, 100 Gb/s and beyond. This research priority provides the essential link between research on components and its applications in systems.

Key areas include developing and understanding the network possibilities that current and future components may bring. We need to understand the potential systems made possible by such technologies and the maximum speeds that can be achieved by using the different components available. Examples might include:

- operation of concatenated, wavelength-selective switches;
- management of optical power transients;
- handling of transparency, reconfigurability, etc.

Fig. 4.1.13
Integrated modulator
wafer for 40 Gb/s RZ
DQPSK © Oclaro

Component design naturally links to architectural aspects such as implications for the control plane. This can then be expanded to understand how to achieve and manage the growth in core network capacity required to support the projected explosion in IP

traffic and bit rates at the network edges. This growth will lead to the development of component technologies for robust 100 Gb/s systems, including 100 Gb/s interfaces using, for instance, multi-level modulation formats, with the associated management requirements. Ultimately this will lead to even higher transmission rates with the next step being predicted to be 400 Gb/s.

It is likely that the development of coherent technologies will increase the need for the implementation of real-time digital signal processing to mitigate optical impairments. This processing is likely to require the development of complex ASICs and ASSPs from silicon design houses. This is another area where European companies have significant strengths.

There have been many lab and field demonstrations of technology at 40 Gb/s, 100 Gb/s and faster, but none of these has come close to delivering the radical reduction in costs needed. The increased data rate drives complexity, dispersion problems, power consumption, packing density and many other factors, including the reduction in transmission distance as rates increase. All of these contribute to an increase in bit transport costs compared to multiple 10 Gb/s channels. The focus of the research activity must be to reverse this situation, allowing European system pro-

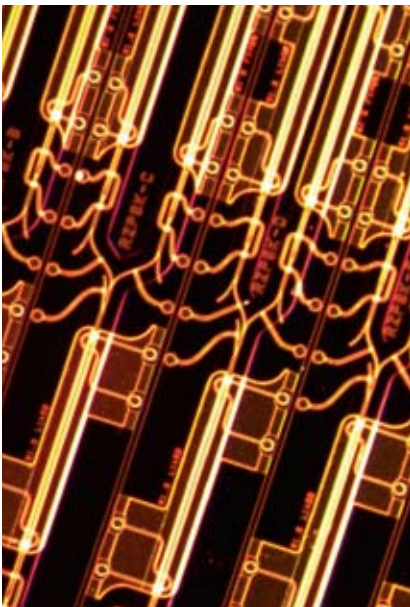

viders, component manufacturers and operators to take the lead in manufacturing and deploying these next-generation systems.

The key technologies to be developed include:

- sources, receivers, optical coding schemes and electronic methods designed to mitigate dispersion;
- packaging and manufacturing technology to reduce the transmit and receive costs and increase functionality and packing density, including multiple channel assembly.

To enable low-cost switching and regeneration, other all-optical components may be essential, including switches, gates and non-linear devices. The target must be to enable 40 Gb/s transport at or near the costs of 10 Gb/s transport today – meaning at least a fourfold reduction in cost per bit.

As a follow-on from the research priority on ultra-high-speed access networks there is an assumption that if the access network evolves to 10 Gb/s and beyond, then there will be upward pressure on the metropolitan and core networks to continue to evolve to rates of 100 Gb/s and above.

The consensus within Photonics21 and in the world telecommunications industry is that the demand for bandwidth will continue to grow at a superlinear rate, fuelling the growth of new services, new ways of doing business and novel ‘infotainment’ applications. The component and systems industries are the enablers of this growth and potentially massive wealth creation. The consequences of Europe not being at the centre of this are most severe. We need to lead in standards, lead in the availability of bandwidth and give our applications industries the best possible platforms from which they can lead. It is clear that this will only work if the industry can deliver more managed bandwidth for less cost on a year on year basis. The capability of the optical transport layer must carve out its own ‘Moore’s law’ of scaling, with cost being the most important parameter.

Europe is already falling behind in the definition, systems and technology development for 100 Gb/s transport. This is not primarily a question of inventing new technologies or pushing technologies to the limit, it is about involving all the nodes in the supply chain to tackle engineering problems that seemed insurmountable only a few years ago. The Framework Programme is a core instrument to facilitate this and make possible pan-European cooperation at the pre-market phase.

This should be achieved by increased efforts in photonic integration technologies, which are essential for providing the functionality needed for the advanced modulation formats required for 100 Gb/s transmission.

The impact of this activity will be felt on many levels:

- leadership of European industry in telecommunications;
- leadership in standards;
- European ownership of key intellectual properties and patents;
- industry and academia working towards a common agenda in photonics systems and components, with academic leadership restored;
- systems leadership culminating in demonstration ‘islands’, enabling development of new applications ahead of the rest of the world;
- leadership in the emerging field of generic photonic integration technology.

It is necessary to deliver truly cost-effective transport at 40 Gb/s, 100 Gb/s and beyond

Expected impact

Fig. 4.1.14 Development and testing of 160 Gb/s transmission systems
© NTUA, Greece



Photonic networking and transmission for energy efficiency in information and communication technologies

Greener optical networks

The energy consumption of communication and data networks is strongly affected by the existing network architecture. It has energy-inefficient components, an unfavourable distribution of active network elements and a suboptimal balance between routing and transport. Energy efficiency is an essential consideration for next-generation networks. To achieve significant improvement, energy efficiency must be included from the beginning as a major criterion in the design and assessment of new network architectures. Various technologies have to be combined to form an overall view of the energy-efficient architecture. Optical networking solutions have considerable potential as the longer transmission spans need fewer active network elements. This is even more important, since energy is consumed not only by the communication equipment itself, but also by ancillary systems such as air conditioning, ventilation and transformers. Optical techniques help to achieve much greater energy efficiency.

The optimised optical access network has an especially high impact on the energy efficiency of the overall network. The requirements to be fulfilled are extended maximum reach of more than 100 kilometres, a high per-client bit rate in the range 1-10 Gb/s, and the use of simple and passive optical technologies as far as possible. Photonics is the only transmission technology able to fulfil these requirements. Fibre to the curb, building, or the home (FTTx) networks are now on the way to being implemented. The replacement of DSL solutions by optical techniques reduces energy consumption in access and in-house networks. Planning tools for such FTTx networks are needed to choose the appropriate solution under different conditions. The optimised optical access network can eliminate sites completely or at least reduce their complexity by removing much of the active electronic equipment required. It allows aggregation layers to be eliminated and consolidated. Layer 2 and layer 3 switching and routing functionalities are concentrated in fewer sites. Besides simplifying the network, this is also expected to significantly reduce power consumption.

Figure 4.1.15 Network architectures for reduced power consumption

Source: BT and ADVA

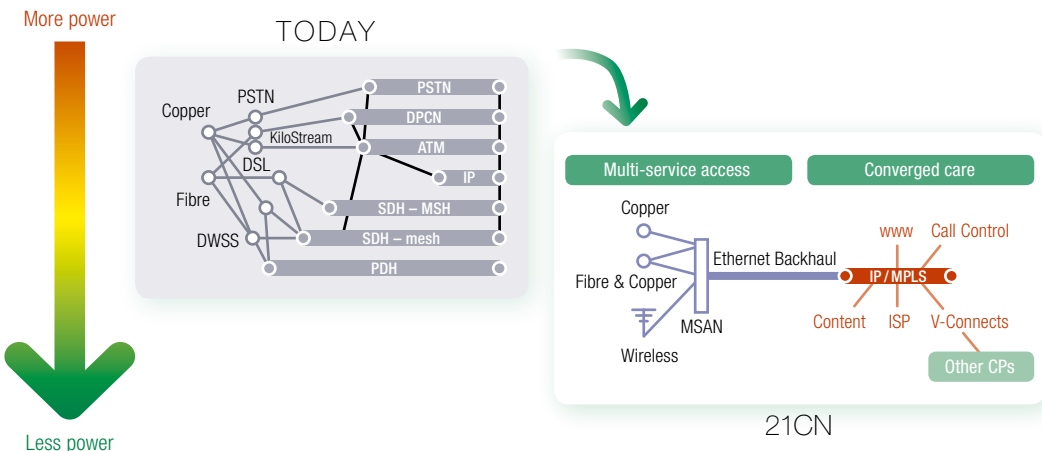

Go horizontal! Eliminate vertical stacks of purpose-built platforms.

Figure 4.1.16 Optical bypass

Source: ADVA

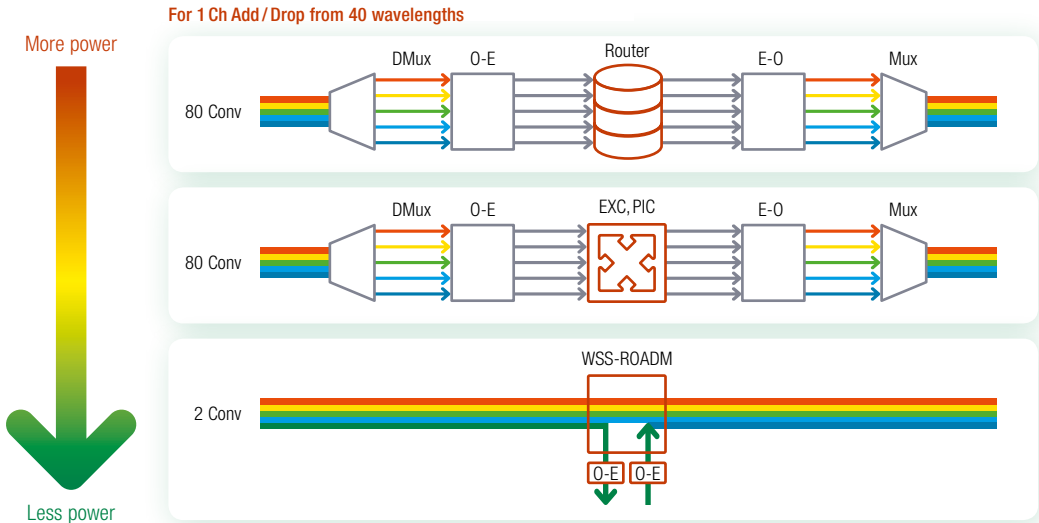

Transport networks already use optical transmission to a large extent, but there is still a need for more capacity and further improvement of energy efficiency. A vision of the future transport network is that of a packet transport network, optimised for cost and energy, scalable to 100 Tb/s throughput per needing much less power.

A big challenge is that the traffic volume is growing much faster than the processing power. IP look-up and forwarding engines will be the biggest energy consumers in the networks. So despite semiconductor technology improvements, power consumption is still growing with bit rate and volume. This challenge can only be solved with novel architectures and technologies, namely optical technologies. As in the access network, the number of network elements, such as routers and switches, can be further reduced due to longer and more efficient transmission links. This in itself already makes a major contribution to energy savings (Figure 4.1.15).

Novel multi-layer switch architectures that allow photonic bypassing of electronic processing achieve scalability towards 100 Tb/s throughputs per node, and at the same time reduce the complexity, power and cost of processing. Multi-layer optimisation of such networks to achieve the best mix of photonics and electronics at lowest cost and power will be an important field of future research. In general, switching at the lowest possible layer and lowest granularities will reduce bit and packet processing and save energy (Figure 4.1.16).

The lesson learned from these considerations is that optical transmission and optical bypass are key to energy-efficient ICT.

The placement and the dimensioning of data centres and their interaction with the dimensioning of the network also have to be taken into account. The integration of optical techniques and wireless systems (base stations) is promising. Novel techniques for the generation and distribution of microwave signals could reduce the energy needs of 3G/4G systems.

Improving the equipment used, in terms of both performance and energy consumption, is a direct path to energy efficiency. This applies to chip sets, network processors and

The optimised optical access network has an especially high impact on the energy efficiency of the overall network



Fig. 4.1.17 System test environment © Ericsson

all the other hardware in routers and base stations, for example. This is also true for new and integrated photonic components. The new developments described for energy-efficient network architectures, with photonics as the major part of the solution, should be accompanied by managing the remaining active network resources for power efficiency rather than being continuously powered. This introduction of low-power modes should be considered at all levels, from chips to systems and even at the network level.

Such 'sleep modes' are not well understood on the network level. On this level one could think of switching off a whole network node, transferring its function to other nodes. There are strong similarities to the restoration mechanism which is triggered by the breakdown of a node. Research is needed into a number of different areas. It is important to have a clear understanding of how fast the network can return to full performance when the load increases again.

There may also be trade-offs between performance and energy consumption which will need to be investigated. The potentially instable behaviour in higher network layers caused by the deactivation and activation mechanisms would need to be understood.

The implication of these mechanisms for network design, defining the right trigger criteria for initialisation or termination, and algorithms for energy saving modes are all items for research.

4.1.5 Technological challenges and research areas

The key drivers outlined earlier in this section provide the underlying key areas that need to be addressed by any research activities in optical communications. The following two key challenges are relevant in 2009 and it is expected the integration of optical functions will continue in the same way as seen in silicon. The initial development of transistors opened up new opportunities. Today we have integrated photonic devices with a few functions; in future we can expect to see much greater numbers of functions being built into a single device.

Generic photonic integration technologies

Photonic integration technologies are of key importance for realisation of the low-cost and high-performance components required in the network. For the new modulation formats required for 100 Gb/s transmission, for example, photonic integration is the only way to provide the required performance. But integration will lead to substantial cost reductions for lower bit rates as well. Mentioned by way of example the central offices in the access network, where substantial numbers of identical circuits can be integrated on a single chip.

Despite their cost-saving potential, the application of photonic integrated solutions has been restricted to a modest number of niche markets. The main reason for the

slow market penetration is the huge fragmentation in integration technologies, most of which have been developed and fully optimised for specific applications. Due to this fragmentation most technologies address a market which is too small to justify further development into a low-cost, high-volume manufacturing process. And new technology development or optimisation is required for each new application, which makes the entry costs high.

This is very different from the situation in microelectronics, where a much bigger market, larger by several orders of magnitude, is served by a smaller number of integration technologies (mainly CMOS) which can address a wide variety of applications. This leads to extensive cost sharing for the large investments required to develop a powerful integration technology.

Europe's key academic and industrial players in photonic integration technology have been cooperating in ePIXnet, a Network of Excellence in the Sixth Framework Programme. The steering committee recommends applying the methodology of micro-electronic integration to the field of photonics by developing a small number of generic integration technologies with a level of functionality that can address a broad range of applications.¹ Such technologies, which should be made accessible via foundries, can address markets that are large enough to recover the development costs.

The recommendation has been followed by a number of activities working towards a foundry model for three major integration technologies: InP-based integration technology, silicon photonics technology and a dielectric waveguide technology which covers the whole wavelength range from visible to infrared. These activities, in which academic and industrial partners are closely cooperating, have provided Europe with an early, internationally recognised lead in this field.

The Framework Programme should further strengthen Europe's position in this emerging technology, which will become the dominant technology in photonic integration. The approach should be holistic, including the development of software design

Photonic integration technologies are of key importance for low-cost, high-performance components

We should apply the methodology of micro-electronics to photonics by developing generic integration technologies

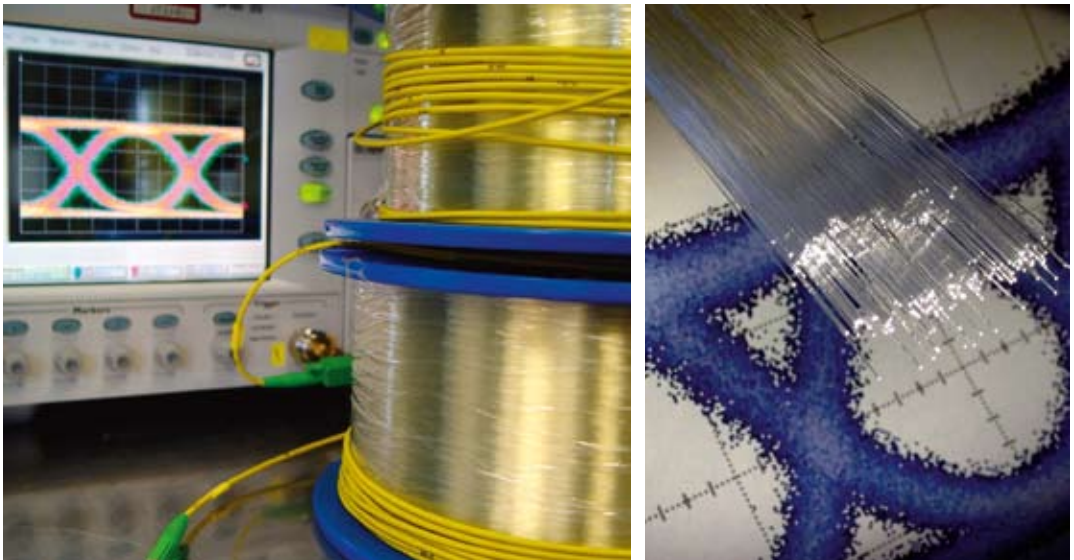

Fig. 4.1.18 Fibre testing © Fraunhofer Heinrich Hertz Institute

¹ "Towards a foundry model for micro- and nanophotonic ICs. A vision for Europe", Network of Excellence ePIXnet.

kits with powerful component libraries and a generic approach toward packaging. Chip dimensions should be standardised along with the positions of the optical and electrical input and output ports. Finally the Framework Programme should stimulate the formation of an ecosystem of users, designers, chip manufacturers, equipment manufacturers and software developers. Here it can build on the start that has been made in ePIXnet.

Optical interconnects

Photonics finds some of its most challenging applications in the access, metropolitan and core networks connecting equipment situated many kilometres apart. But photonics is also a key enabling technology in short-reach optical communications used to interconnect devices within equipment, for short-range, free-space optical communications and for very short-reach optical interfaces at high bit rates.

Optical fibre connections are also used in various data networks such as local area (LAN) and storage area (SAN) networks. They play an increasingly important role in computer networks – in data centres or ‘server farms’, for instance. The connections vary in length, from a few metres to around 10 kilometres.

As already observed in telecommunication networks, the transmitted data volumes are expected to increase at high growth rates. Data rates in the Tb/s range for a single connection appear realistic in five to ten years. Cost efficiency plays a significant role in this type of application, as does the drastic reduction of energy consumption. Optical technologies dissipate less heat and so need less cooling and ventilation equipment.

Fig. 4.1.19
Fibres are the basis
of optical networks
© Fotolia

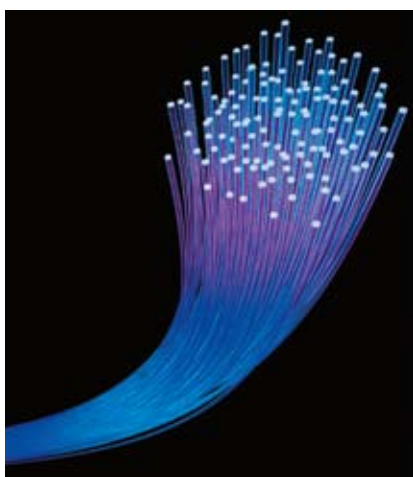

Potential R&D topics include:

- increasing the single channel rate the current 10 Gb/s to 100 Gb/s and above;
- parallel transmission based on TDM and WDM;
- high-bit-rate transmission systems based on multimode fibres;
- high-bit-rate transmission systems based on plastic fibres (POF);
- high-capacity, short-range, free-space optical transmission up to Tb/s.

The technology is being considered for micro-, short- and medium-range communications, including (but not limited to) on-chip communications within computers, inter-chip communications, backplane connections within servers and switches, communications between boxes, connectivity in the consumer and business electronics environment.

Context

Photonics will find effective and profitable applications wherever conventional electronic interconnections meet intrinsic limitations caused by attenuation, power consumption and crosstalk.

This is happening more and more often in ICT equipment where an enormous quantity of data has to be processed and transmitted over very high density, very high speed lines. As an example, within the next decade the traffic capacity on a multi-core CPU is foreseen to reach several tens of Tb/s.

Copper links used in chip-to-chip, board-to-board and equipment-to-equipment connections require sophisticated I/O buffers, including complex equalisation circuitry at the price of costly power dissipation. They have to be mounted on PCBs and backplanes with several constraints on the design of the layout.

Figure 4.1.20 Revenue and unit forecast for active optical cables

Source: IGI Active Optical Cables Market Report 2009

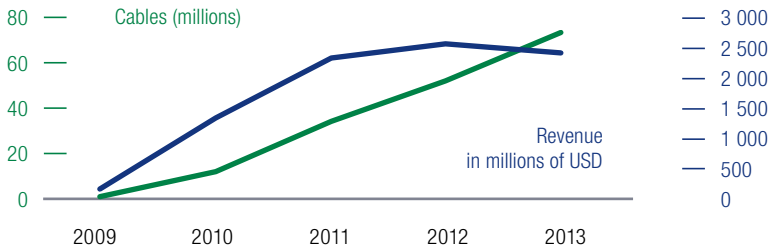

In many cases in the development of the new generation of electronic equipment, the 'fundamental' limit found above speeds of 10 Gb/s has already been encountered. Optical interconnections have practically unlimited bandwidth and an absence of crosstalk, which is why such technology is seen as the best solution.

Active optical cables (AOCs) are optical communication links using digital electronic interfaces. Optic-electronic conversion is made inside the connectors. AOCs are well adapted to links running at or above 5 Gb/s, as well as to applications demanding extended cable lengths beyond 2 to 5 metres at these speeds. Copper-based cables are already experiencing significant challenges in this performance range, thus offering AOC providers an opportunity to move into this market. As shown in Figure 4.1.20, very high volumes are expected in the coming years.

AOCs are expected to generate significant business growth over the next five years in several key segments: mainframe and supercomputers; desktop, notebook and portable personal computers, high-definition television and consumer electronics devices.

Most of today's active cables are based on 850-nm VCSEL laser sources. Discrete elements such as VCSELs, drivers, photodiodes and transimpedance amplifiers are assembled and placed inside the connector. A few companies in the world are now developing a silicon photonics technology platform for active cables. It allows the integration of several complete fibre optic transceivers at each end of the cable. ●○

Optical interconnections have practically unlimited bandwidth and an absence of crosstalk

Management summary: Overview table

Market overview

Global market

- Overall telecom market 2008: \$3400 billion
- Optical network equipment market 2008: \$14 billion
- Optical component market: \$4 billion
- Telecom in EU-27 continues to show uninterrupted growth over the past 9 years.

Europe's position

- Europe has very strong leadership in communications technologies.
- Worldwide optical network HW market in 2008 was \$15 billion.
- EU companies or companies with significant EU operations have 45% of that market.

Ultra-fast broadband

- Broadband speeds are rising at more than 50% per annum (Europe needs to keep up with these trends).
- High-end broadband usage is growing at 20% per annum.
- FTTH broadband homes drive 3 times more traffic than ADSL in Europe.

Focus areas

- Ultra-fast broadband
- Components and technologies for high-speed broadband networks to the user are essential.
- Core network flexibility, speed and transparency
- Network convergence

Technological challenges	Communications and networking	Interconnects
Make it faster	<ul style="list-style-type: none"> • Power consumption increases as speed increases. • Reach limitations due to OSNR and impairment challenges. • Components technology availability and evolution • DSP algorithms and chip-sets • Operation over mixed fibre types • Equipment footprint 	<ul style="list-style-type: none"> • Power consumption increases as speed increases. • Seamless replacement of copper links by optical links • Scalability
Make it transparent	<ul style="list-style-type: none"> • Wireless and land line convergence • Metro and access convergence • Reduce O-E-O conversions • Operation over mixed fibre types • Variable bit rate 	<ul style="list-style-type: none"> • Wireless and land line convergence • Operation over SMF/MMF/PCB
Make it more dynamic	<ul style="list-style-type: none"> • Network convergence • Network responsiveness to changing traffic demands • Protection and restoration • Insertion of new equipment 	
Make it greener	<ul style="list-style-type: none"> • Total energy usage in end-to-end network • Trade off between spectral efficiency and energy dissipation per bit • Avoid O-E-O conversions. • Move power-hungry switching to the edge of the network. • Eliminate vertical stacks of purpose-built platforms. 	<ul style="list-style-type: none"> • Efficient E-O-E conversion • Avoid O-E-O conversions.

Research areas	Communications and networking	Interconnects
Make it faster	<ul style="list-style-type: none"> • Spectrally efficient transmission • Modulation formats – DQPSK, OFDM • Coherent detection • 100 Gb/s • 10 Gb/s optical access • DSP and soft photonics • Managing nonlinear impairments • Forward error correction • 1 and 10 Tb/s Ethernet 	<ul style="list-style-type: none"> • Integration of photonics with electronics • High-speed modulated lasers (direct or external modulation scheme) • Integrated digital signal processing • Decrease cost of Gb/s to compete with copper links.
Make it transparent	<ul style="list-style-type: none"> • Network convergence • New network architectures • Meshed transparent networks • Different data formats e.g. QPSK, SCM, OFDM • Coherence and the use of DSP • Increase reach • Long reach access networks • Link design • Optical bypass • Next generation ROADMs • All-optical processing e.g. regeneration and wavelength conversion 	<ul style="list-style-type: none"> • Integrated all-optical processing
Make it more dynamic	<ul style="list-style-type: none"> • Fast provisioning and reconfiguration • Control plane and routing algorithms • Network self-reconfiguration – self-learning and auto-discovery of resources – zero-touch photonics • Impairment-aware, energy-aware software for establishing connections • Variable bit rate • Optical cross-connects • Adding and dropping sub-bands in/from multicarrier signals • Optical packet switching • Flow switching 	<ul style="list-style-type: none"> • Photonics/electronics integration: use of electronics to improve the performance and functionalities of photonic functions at negligible cost

Make it greener

- Uncooled and high-temperature devices
- Minimise energy dissipation
- Power saving strategies e.g. turning off unused resources
- Passive devices in particular for street level devices
- Traffic bypass implementation using ROADM technologies
- Long reach WDM-PON
- Photonic integration
- Energy-efficient network architectures with end-to-end perspective
- Energy-aware photonic networks planning
- Photonics/electronics integration: use of electronics to compensate for fabrication dispersions and thermal drifts
- Decrease pJ/bit energy consumption to compete with copper links
- Low cost integrated transceivers
- Low power consumption modulators

4.2

Manufacturing and quality

Cutting and joining, ablation and deposition, drilling, marking – and the list goes on. Lasers handle a wide array of manufacturing tasks, working materials ranging from steel and plastics to semiconductors. Even diamonds yield to the laser's focused power. From the smallest to the largest, from mass-produced components to one-of-a-kind parts, the laser beam is one of the most versatile tools of our time.

4.2.1

Market overview, main drivers and challenges

Traditionally Europe holds a leading position in industrial laser technologies, both in research and in business strength. The economic leadership is based on leading roles in developing, supplying and applying lasers and laser systems. Figure 4.2.2 shows the principal segments of this market.

Although the market for laser sources used to process materials has had a persistent and significant 10% annual growth rate in the past decade (Figure 4.2.3), the world financial and economical crisis will lead to a shrinkage of 30 to 40% in 2009 compared to the previous year. Based on 2008 figures this will mean that the world market volume for laser materials processing systems in 2009 will be roughly €4 billion. Depending on further market development and a stabilisation of macroeconomic factors, laser suppliers will face rough conditions in 2010 as well. Leading laser market experts are anticipating, after economic revival, a continuation of the solid growth rates seen before the crisis.

The main drivers for the use of laser technology in future applications are new wavelengths, higher output power (both average and peak), shorter pulses, higher power efficiencies, smaller components and lower costs. In order to maintain and improve the

Leading laser market experts expect solid growth rates to resume

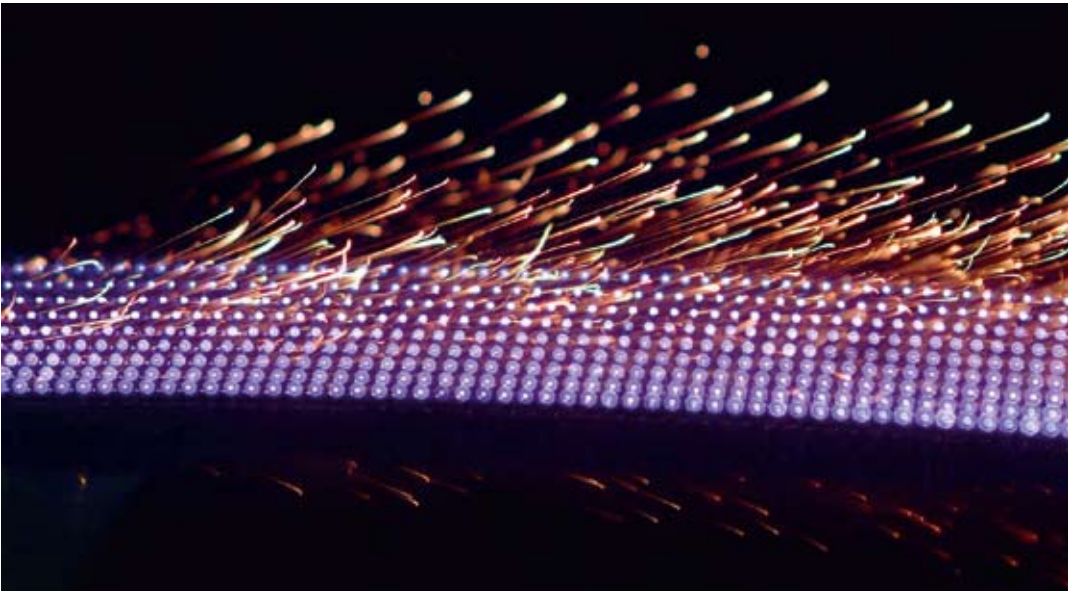
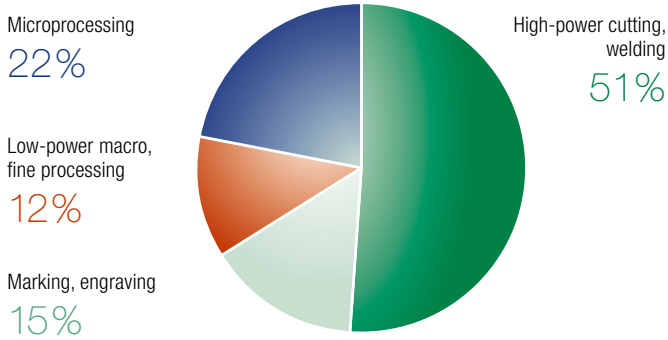

Fig. 4.2.1 Laser drilling of solar cells © Fraunhofer-Institut für Lasertechnik

Figure 4.2.2 World market for laser materials processing systems 2008 by application

Total: EUR 6.4 billion Source: Optech Consulting (March 2009)



leading position of laser science in Europe and the competitiveness of its laser industry, solid funding for research and development is needed to meet the future needs of applications in Europe and worldwide.

Future high-volume applications will generate a demand for laser systems to process high-strength steels, lightweight and crash-safe car bodies, photovoltaics and semiconductors, tubes and profiles, and miniaturised components in medical technology. There will be lively demand for technical, laser-made surface structures in many markets. Furthermore the trend towards customisation and the growing importance of industrial design, for example in consumer electronics, will require new methods for making new product shapes and 'lot size one' production capabilities, with which single items are manufactured.

The most challenging problem in manufacturing laser sources is price pressure, resulting from low-cost competition primarily in Asia. In response, the manufacturing sector in Europe must invest in high-quality, highly automated workstations and processes.

Figure 4.2.3 World market for laser-based materials processing systems

in billions of euros Source: Optech Consulting (March 2009)

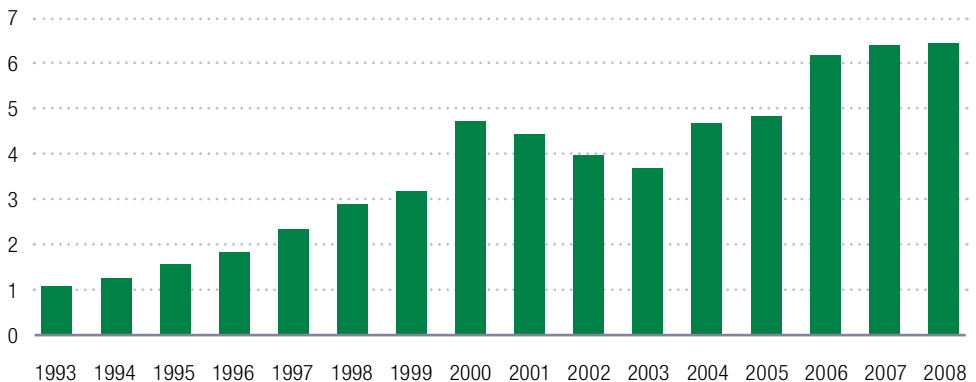



Fig. 4.2.4 Laser welding with a TruFlow laser
© TRUMPF GmbH + Co. KG

If Europe's laser industry can maintain its competitive edge, then there will be an opportunity to deliver equipment to the Americas and to Asia's emerging markets. In this case, the laser sector will make a positive contribution to Europe's trade balance and employment.

4.2.2

Europe's position

Europe holds a leading position in the world market for photonics used in industrial production. The world's largest laser companies have their headquarters in Europe (Rofin-Sinar, TRUMPF, and so on) as do many manufacturers of key laser components. Europeans benefit from a broad education, at high average academic achievement levels, provided by a dense network of universities, research institutes and other educational facilities. These cover all aspects of practical and theoretical skills while providing an adequate educational system for people of various talents.

Europe holds leading position in the world market for photonics in industrial production

Several leading researchers in photonics were born in Europe and have established excellent research facilities here with expertise in key areas. They are now in a unique position to transfer know-how to industry. Industry itself has made major efforts to support these facilities, in addition to their own R&D activities in photonic technologies. While major R&D efforts today are limited to larger companies, smaller companies have always been innovative and would profit tremendously from a strengthened European initiative in photonics.

Europe's lead in laser technology is vulnerable to competition from Asian companies able to compete on price. Suppliers from China, Japan and emerging economies have secured a share of the market for smaller installations and bulk orders. These companies are improving their quality all the time, leading to a situation where prices are falling while one of Europe's main competitive advantages shrinks. For now, Europe's laser technology is still ahead in terms of innovative technology and optical excellence.

4.2.3

Technological challenges and research areas

Technological challenges

Manufacturing technologies based on interactions between photons and matter require a thorough understanding of the physical fundamentals, namely Maxwell's equations and basic quantum optics. Industrial manufacturing applications also have to take account of the economic environment to make the best use of scientific knowledge. Europe leads the world in photonics, with research institutions and industry able to exploit and apply the scientific results. Europe's leading position in engineering and machine tool

Science and research into manufacturing and quality

manufacturing can only be secured by constant innovation, with new photon sources and engineering solutions promising faster and more flexible production techniques and even completely new methods.

This constant quest for new photonic technologies will also have to consider the social and economic benefits. The environmental impacts of new components, processes and products will have to be assessed from the very beginning of the design phase and consider the entire life cycle, right through to the recycling of the final products. Difficulties are not rooted in basic physical laws but stem from the technical shortcomings of the optical components and systems in use today. Science will need to address the physical and technical limits of materials used in optical components as well as the deficiencies of the manufacturing process itself. In future, the 'quality' of goods and products will take account of their impact on the environment.

In future the main research and engineering efforts will focus on more efficient lasers (more light output for a given energy input), longer-lasting components that can be readily recycled, and maintenance-free manufacturing equipment. The increasing integration scale of components to ensure quality management and traceability of the final manufactured product will make all the difference to future mass-manufacturing installations. The markets for new light sources, new processing strategies and new photon transmission systems will be addressed. Better integration of the system components and the processes resulting from these efforts will ultimately drive innovation in science, technical engineering and industry.

The physical and technical limitations of today's optical components can only be overcome by interdisciplinary research efforts in manufacturing technologies, microsystem engineering, nanotechnology, telecommunications and optics. More fundamental limitations must be tackled by basic research on the interaction between light and matter, on novel materials and on structures with revolutionary photonic properties. This will require work in materials science, quantum optics, thermodynamics and solid-state physics.

All this research will open the way to groundbreaking new optical components and the corresponding technologies for their fabrication which, in turn, will lead to new photonic processes in manufacturing. These new processes will be more flexible, more functional and more productive. They will strengthen Europe's leading position on the world market for photonic technologies and mechanical engineering and sustain this position in the future.

The industrial partners in Photonics21 believe that the manufacturing industry has hardly begun to exploit the potential of photonics. A complete redesign of the underlying processes will make possible radically new manufacturing solutions. The challenge for industry is to develop and implement these solutions.

In the next decade the photon will be used in many fields of production, some of which are already known but most of which are new. They include:

- macro- and microprocessing;
- lithography;
- optical quality control;
- optical sensing;
- new materials dedicated to photon processing;
- biotechnology;
- medical applications.

Europe's leading position in engineering and machine-tool manufacture can be maintained only through constant innovation

Market sectors

Key technology areas



Fig. 4.2.5
Hybrid laser-arc welding
of an aluminium axle
© TWI Ltd

These markets and applications will grow as the new photonic tools become more sophisticated.

New opportunities for design and manufacturing will require highly qualified personnel at all levels. Demand for skilled staff will continue to increase and special efforts in education and training will be necessary to meet this demand. The creativity of skilled individuals will be a key factor in ensuring innovation and maintaining Europe's leading position in photonics manufacturing.

Research areas

The choice of primary research areas derives from the process of technological evolution necessary for successful product development. We propose a strategy which covers all steps in the manufacturing process, from basic research and development to the products themselves and their market penetration. Sustainable success in the market requires a broad and deep understanding of photonic manufacturing processes. The potential of photonics emerges both from current applications of photonic tools and from completely new applications that will be discovered as a result of the photon's unique properties.

Beam sources such as lasers play a major role in these applications. We need to further improve existing beam sources and develop new ones, and do the same for related technologies such as beam delivery and beam manipulation. Further development of optical materials used in beam sources is required, along with optical systems. The aim is to create industrial-grade systems that can meet tomorrow's demands.

Another focus is on the process itself, where the interaction between light and matter defines its intrinsic properties. Improved or advanced processes will need a complete understanding of the interplay between the laser beam, the material and the surrounding atmosphere. Finally, diagnostics and quality assurance must be addressed. Intensive development of sensor technology is necessary to meet these demands.

A further challenge is to integrate and scale down today's solutions so as to broaden their applicability. Materials such as ceramics and plastics are promising candidates for new applications along with classical metal processing.

A closed development cycle consisting of beam source, process and quality assurance has to be established to embark upon a path towards superior solutions for the manufacturing processes.

Besides successful research and product development, the manufacturing sector needs to be educated about the potential that laser-assisted fabrication can offer to a particular application. We need to strengthen existing laser institutes and application centres and their interaction with industry. In Eastern Europe, for example, there are only a few institutes capable of transferring to local companies knowledge about laser processing of materials. This is becoming even more crucial since many of the

manufacturing steps in the automotive industry have already been moved to Eastern Europe or will do so in future.

Research priorities in machine vision and photonic quality assurance are relevant to an extremely broad range of applications covering the entire field of industrial production, manufacturing and quality, including assembly, robot vision and metrology. Therefore a major potential for improvements in production technology needs to be tapped by developing more sophisticated machine vision components and systems than those available today.

Fig. 4.2.6
Femtosecond lasers can be used for creating nanoparticles and micro-components, or for structuring materials for cochlear implants © Laser Zentrum Hannover

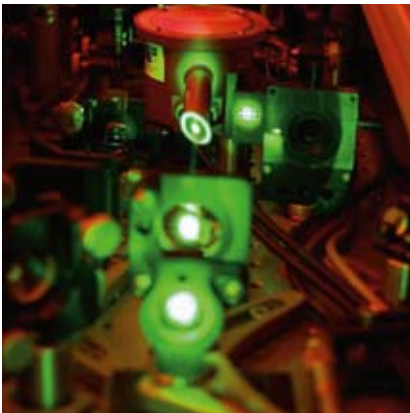

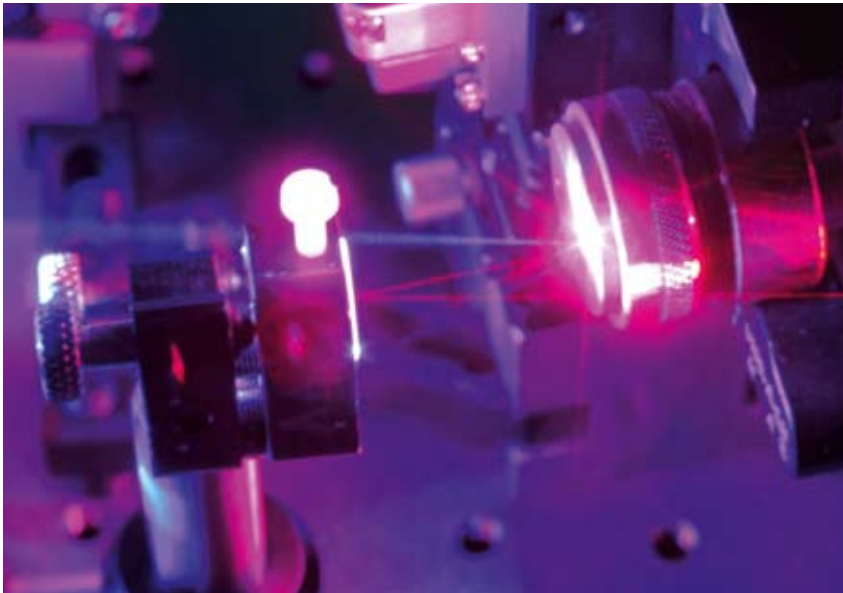

Fig. 4.2.7 Optically pumped, vertical cavity, surface emitting lasers (VCSELs) © Institute of Photonics, SUPA, University of Strathclyde, Glasgow

Great emphasis will have to be given to the development of new 3-D imaging technologies. Current techniques still have technical restrictions and are relatively expensive, so 2-D solutions are often used where 3-D solutions would be clearly preferable. New 3-D techniques (such as those based on ‘time-of-flight’ principles) would extend the technological leadership of the European machine vision industry and have a significant impact on the competitiveness of its products.

Another important research priority for machine vision is the use of multiple sensors, which combine the imaging of different physical effects invisible to the human eye. This will allow a wide variety of parameters to be measured in the production process, including the chemical composition of workpieces or substances. True colour measurement systems will further enhance innovation and competitiveness in manufacturing. In very general terms, machine vision systems will have to become faster, more compact, more precise, more robust and more easily applicable.

The following discussion of research topics, with special emphasis on the next five years, has been divided into the domains ‘Photon sources and optical components’ and ‘Process development and manufacturing systems’.

Photon sources and optical components

Improved laser sources are continually revolutionising production technologies. They bring higher speeds and more cost-effective productivity to all manufacturing sectors, from machine tools to automotive and aerospace. The current world market for laser sources is worth more than €1.5 billion a year and its steady growth depends crucially on continuous product development. Some improvements come from new laser sources such as disc and fibre lasers. On the other hand, the technical progress, lower costs and increased reliability of modern solid-state lasers are strongly driven by improvements in diode lasers. Further advances in diode lasers will make them suitable for direct use in material processing.

High-power lasers with improved performance in power, beam properties and efficiency



Fig. 4.2.8 Development of LIMO laser systems © LIMO/Markus Steur

The driving forces in laser development are saving energy in high-end manufacturing and high productivity rates to facilitate reconfigurable production units. Highly competitive and affordable laser sources will help broaden the acceptance of the laser as an industrial tool.

Emphasis should be placed on development of continuous wave (CW) lasers with premium beam quality at 10 kW of power and above and wall-plug efficiencies exceeding 25%. Diffraction-limited short and ultra-short pulse lasers with repetition rates up to 100 MHz and pulse energies in the 10 μ J range are needed, as are high-brilliance diode lasers with power in the kilowatt range and nearly diffraction-limited beam quality. More generally speaking, industry needs lasers with better spatial and temporal control and stability.

The development of reliable lasers needs simulation tools adapted to the different sectors. This is especially true for solid-state lasers where the wave propagation has to be characterised to anticipate the thermo-optical effects.

Lasers at new wavelengths and improved spectral characteristics

The 10% annual growth averaged over the past decade was attained almost exclusively with lasers operating at one of two wavelengths: 10.6 μ m and around 1 μ m. An expansion of the available wavelengths will multiply the growth potential of the laser systems market and make it easier to optimise the processes required by the manufacturing industries.

Short-wavelength lasers can be used to improve the efficiency of the process or to measure faster and more precisely. Reliable and versatile frequency conversion systems are needed, as are high-power laser sources of variable wavelength for manufacturing and quality control. Looking at other wavelengths will also facilitate the production of high-power, eye-safe lasers for photonic manufacturing and measuring processes.

The ability to tailor the wavelength of a laser to the required manufacturing process remains a major challenge.

Simple and reproducible methods for assembling lasers could help to reduce cost and make high-power laser systems more reliable. The precision required to assemble reliable laser sources is a major technical challenge and an important cost factor. We need technologies and processes that will allow systems to operate unattended but reliably for long periods at precision better than one micrometre.

A precision process to assemble all the parts of a laser is crucial because it has to be done reliably and cheaply. Microlasers have been manufactured successfully at a high level of integration but are limited in power. One way to reach a similar level of integration for high-power lasers would be to build them as single blocks. This technological challenge will need new, stable materials and assembly methods but could lead to more reliable sources.

Fibre-optic beam delivery is one of the most frequent reasons for using modern solid-state lasers. This key advantage would be lost if advances in fibre-optic beam guides were not to keep up with advances in the laser sources themselves. This could lead to a severe weakening of the solid-state laser market. While the great majority of fibres are designed to operate from the visible to about 2 μm wavelength, many applications, including manufacturing, require transmission in the 2 to 10 μm range. Possible approaches to a low-loss, infrared fibre include new chalcogenide glasses, extrusion of polycrystalline silver halide fibres and photonics bandgap structures with an air core.

Today's fibre-optic beam delivery systems are usually point-to-point connections. True laser-on-demand systems in modern laser-sharing manufacturing will require adaptively reconfigurable beam delivery networks. This results in a need for reconfigurable production equipment at lower investment costs. Fibre-optic beam delivery is very attractive for laser-sharing applications in large production facilities. Fibre-integrated components such as optical isolators, beam switches, fused fibre-optic components and tapers required for flexible beam delivery networks are not sufficiently developed today. Hence we need optical fibres for the delivery of multi-kilowatt diffraction-limited beams and pulsed laser radiation in the millijoule range with low loss and low mode mixing down to

Novel
assembling
technologies

Optical fibres
with novel
wave-guiding
concepts and
fibre-optic/
integrated
optical
components



Fig. 4.2.9 Fibre-coupled diode laser © Fraunhofer-Institut für Lasertechnik

bending radii of 200 mm. The development of integrated optical isolators, active beam switches and taper structures goes along with this task.

Beam shaping,
phase control,
beams tailored
temporally
and spatially,
highly dynamic
focusing optics

Being able to adapt the properties of the laser beam to the process at hand will open up completely new process strategies and significantly increase the efficiency of the process, improve the quality of the manufactured product and also help to reduce cost.

To do this, we need to develop adaptive components to shape the beam intensity, the beam polarisation states as well as the temporal pulse shapes to suit the application. Components that are thermally compensating will be crucial for a wide dynamic range of operation. They will also help negate thermal lensing effects which become extremely problematic in high-power laser delivery systems. Passive components such as specific diffractive optics will also be required.

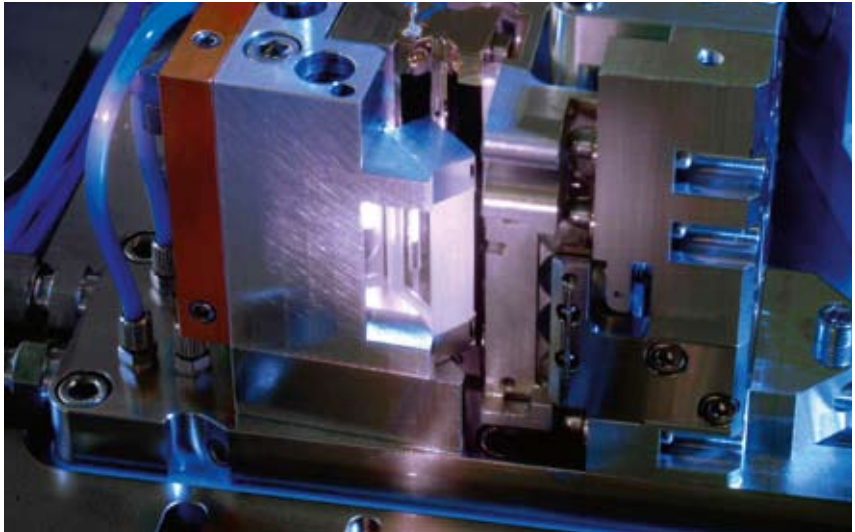

Fig. 4.2.10 Yb:YAG, 400 W average power, femtosecond amplifier © Fraunhofer-Institut für Lasertechnik

Optical
materials,
components
and coatings

Optical components can be damaged if the power passing through them exceeds a certain value. Raising this damage threshold and reducing the absorption of light by optical materials improves the degree of integration and significantly extends the life of optical components. It also reduces costs and increases the reliability of high-power systems. This could lead to robust manufacturing systems with low maintenance costs.

Materials with very high damage thresholds and wider spectral acceptance are required. Some of the issues included are tailored absorption, reflection, scattering, dispersion and refractive index. Optical materials with ultra-low absorption are a major challenge.

As the limiting damage threshold is often located at the optical interface of the material, the processing and coating of the surface are key to providing components with maximum performance. Material processing techniques to reduce sub-surface damage present one of the major challenges in reducing scattering losses in each optical component (passive as well as active). Closely related to the increasing requirement for more stringent surface quality is the requirement for ultra-high-power coatings. Higher energy densities are placing ever greater demands on coating specifications. Absorption within the coating must be considered in the development of new coating materials and techniques.

The operating envelope of active intra-cavity components such as acousto-optic and electro-optic Q-switches needs to be increased to enable high performance operation (and indeed system shipment) under harsh environmental conditions such as extremes of temperature. This will allow systems to operate in remote geographical areas as well as in hazardous environments such as hard radiation or high-power UV laser radiation.

Process development and manufacturing systems

The current running-in phases required whenever a manufacturing process is changed are time-consuming and expensive, especially when they have to be repeated after each change of input parameters. Predicting of the process parameters by simulation rather than by trial-and-error experiment will speed up the modification of manufacturing processes to accommodate new products and changing environmental conditions. A more efficient process will also reduce costs, save energy and protect the environment. Higher speed increases the productivity and hence the profitability of manufacturing processes. Likewise, incorporating novel advanced materials into future products will drive innovation in areas such as energy saving and safety. Knowledge of how photon-matter interaction influences the properties of specific materials will help direct the development of future advanced materials. Absorption in the material, heat conductivity, multi-photon processes, dynamics of melt, vapour and plasma, or electromagnetic forces will all require special attention.

As a consequence, it remains a challenge to develop robust and low-cost manufacturing processes which are also highly efficient and save energy. However, quality suffers at higher speeds and so far this has limited productivity.

Reliable models and comprehensive simulation tools for material processing are also needed. Processes can be made more efficient by improving the coupling efficiency between the beam and the workpiece by optimising the local atmosphere. Novel strategies such as remote and scanner technologies will also help ensure quality at higher processing speeds. The applications driving development include fault-free welding, drilling and texturing of ultra-high-strength steels, aluminium alloys, plastics, composite materials, semiconductors and organic materials.

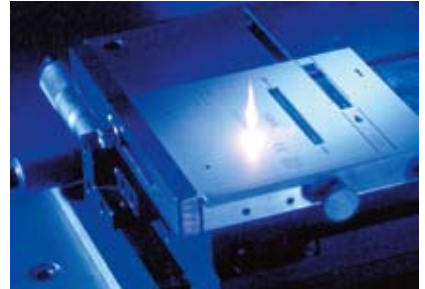

Fig. 4.2.11
The process of laser marking © Rofin-Sinar Laser GmbH

The identification of processing domains will introduce the change from technology charts to scientific systematics and machine-independent self-optimisation of laser manufacturing systems. Intelligent sensing techniques, requiring high computing power, will lead to integrated monitoring and control systems for zero-fault production. Hence, intelligent production using real-time process control is a vital development on the route towards the vision of zero-fault production at high productivity, high yields and the resultant low costs and high competitiveness. The ideal situation of 'lot size one' is based on consequent implementation of intelligent process sensing, monitoring and control.

Robust and reliable manufacturing processes with the possible consumption of energy and materials at low cost will have considerable effects on European competitiveness. Online diagnostics and real-time control of the manufacturing processes are essential and will require a thoroughgoing understanding of the underlying processes.

Important steps on this road are intelligent sensors using new principles, such as true colour measurement and multispectral imaging for process control. Other areas to be tackled include 1-D to 3-D high-speed sensing and imaging and coherent and incoherent illumination of the processing area to help determine geometric quantities. The next step will be to integrate detectors, sensors and signal processing units into closed-loop

Investigations of interactions between light and matter, process efficiency and laser processing of new materials

Process diagnosis at shorter spatial and temporal scales and online control of production processes

feedback systems. These will make possible a holistic, real-time approach to quality control before, during and after the processing stage.

Hybrid processing technologies

Hybrid processes combine laser energy with other forms of power. They can enhance speed, quality and productivity of specific applications and so increase the efficiency of the process. Added product functionalities due to surface treatment are also possible.

New forms of combined processes like laser-plasma, laser-current, or laser-magnetic field will create new applications and therefore open up new markets. Reduction of wear and friction in parts subjected to tribological loading is a further issue to be addressed.

Workpiece material science

An early assessment of the suitability of novel materials for production processes avoids the risk of expensive breakdown of entire production chains due to incompatible materials. Advanced materials that are continuously introduced in new products are also a major challenge for photonic manufacturing systems. In future they should be examined for their suitability for the photonic manufacturing processes.

Based on the experience gained in processing new materials (see above) the common specifications used in conventional processing methods for the mechanical properties of novel materials should be extended to the requirements of laser processing.

Build-up and repair using material additive processes

Additive laser processes, those that deposit material rather than remove it, can be used to repair expensive tools quickly and cost-effectively. They can also be used to manufacture complete tools and serial products and for faster prototyping and rapid tooling of mechanical machine parts.

Research topics include coatings and material build-up, with customised properties such as strength, thermal characteristics and porosity. Optimised shaping and surface



Fig. 4.2.12 Single-sided tube cutting with fibre laser
© TWI Ltd

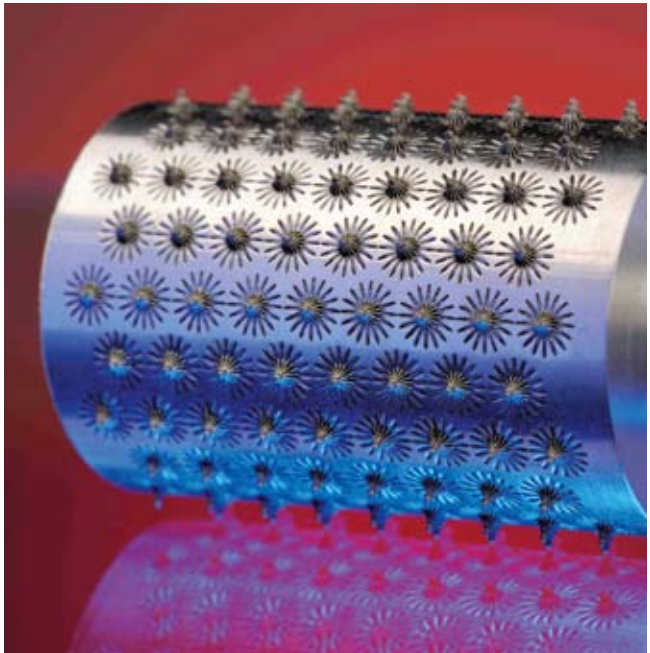

Fig. 4.2.13 Surface modification by laser-induced movement of molten material
© TWI Ltd



Fig. 4.2.14 Cutting and welding an automotive component with a laser combination head in one setup © Fraunhofer-Institut für Lasertechnik

treatment on the micrometre scale are then required to manufacture individual parts without further processing.

Today, much effort and emphasis are placed on developing intelligent manufacturing systems. Since photon sources are extremely flexible tools, they are very well suited for setting up complex production systems. They can produce small batches according to the 'mass customisation principle' in which the running-in and testing phases are kept to a minimum and each part produced can be regarded as an individual product. This requires a high degree of autonomy for the manufacturing system, incorporating intelligent sensing and control components, process planning tools, and closed-loop feedback of the manufacturing results. The development of this technology requires that the research priorities of the *Manufacture* European Technology Platform be applied to laser manufacturing systems.

A logical step towards this challenging goal is to integrate versatile and adaptable laser sources into flexible and intelligent beam delivery networks ('laser on demand') for process-adaptive and autonomous manufacturing systems. In the long term, intelligent manufacturing systems will avoid lengthy and costly run-in phases and allow the 'photon factory' to adapt to the changing needs of the market. The different fields of industrial manufacturing and quality will then come together to implement the vision of the photon factory. ●○○

.....
New,
maintenance-
free laser
manufacturing
systems
.....

Management summary: Manufacturing and quality

Market overview

- The market for laser-based material processing systems has shown a persistent and significant 10% annual growth rate in the last decade.
- World market volume in 2008 was roughly €6.4 billion.
- Due to the world financial and economic crisis, in 2009 a shrinkage of 30 to 40% is expected, but leading laser market experts expect a return to the solid growth rates seen before the crisis once economic pick-up has occurred.
- The main driving forces behind the use of laser technology in future applications will be higher output power, new wavelengths, shorter pulses, higher power efficiencies, adaptive sources, lower costs, and integrated photonic production concepts.
- Future high-volume applications will generate a demand for laser systems to process, for example, lightweight and crash-safe car bodies, photovoltaics and semiconductors, and miniaturised components in medical technology.
- The trend to customisation and the growing importance of industrial design, for example in consumer electronics, will require new methods to enable new product shapes and lot-size-one production capabilities.
- The most challenging problem in laser source manufacturing is price pressure, a result of cost competition exerted mainly by Asia.

Europe's position

- Europe is in a leading position in the world market for photonics in industrial production. The world's largest laser companies have their headquarters in Europe as do many manufacturers of key laser components.
- Europeans benefit from a broad education, at high average academic achievement levels, provided by a dense network of universities, research institutes and other educational facilities.
- Europe's lead in laser technology is vulnerable to competition from Asian companies able to compete on price. Suppliers from Asia are improving their quality all the time, leading to a situation where prices are falling while one of Europe's main competitive advantages shrinks.
- Europe's laser technology is still ahead in terms of innovative technology and optical excellence. There is an opportunity to deliver equipment to the Americas and to the emerging markets in Asia if Europe can maintain its competitive edge.

Focus areas	Photon sources and optical components	Process development and manufacturing systems
Technological challenges	<ul style="list-style-type: none"> • Reliable, reproducible and precise methods for automated assembly of photonic devices • Lasers with improved performance in power, beam properties, and efficiency as well as better spatial and temporal control and stability, all at lower costs • Adaptive photon sources, e.g. tailoring the wavelength of a laser to the required manufacturing process • Adaptively reconfigurable beam delivery networks capable of high powers and intensities 	<ul style="list-style-type: none"> • Prediction of process parameters and machine-independent self-optimisation of laser manufacturing systems; reconfigurable production units • Real-time process control and adjustment to ensure zero-fault production • Laser on demand for process-adaptive and autonomous manufacturing systems • Enabling cost-effective use of lasers in production lines by increasing the duty cycle from today's 30%
Research areas	<ul style="list-style-type: none"> • Novel assembly technologies • Advanced/adaptive laser sources • New laser wavelengths • Novel wave guidance concepts and fibre-optic/integrated optical components • Tailoring material properties such as absorption, dispersion and refractive index • Temporally and spatially tailored beams, highly dynamic focusing optics • Higher damage thresholds, tailored light, and increased reliability thanks to new optical materials, components and coatings 	<ul style="list-style-type: none"> • Basic studies on the light-matter interaction, process efficiency and laser processing for new materials. • Process diagnoses at shorter spatial and temporal scales and online control of production processes • Hybrid technologies in macro-, micro- and nano-processing and laser processing of novel structures • Integration of adaptive laser sources with intelligent sensing and control components, process planning tools, and closed-loop feedback

4.3

Healthcare and life science

4.3.1

Market overview, main drivers and challenges

Photons are unique enabling tools for healthcare and life science and photonics has a long tradition in these fields. The microscope has opened a window into the world of cells and bacteria and is now a powerful, modern tool for basic biological research into cell processes. Recent innovations in microscopy make it possible to image cells in living organisms whilst ultra-high-resolution systems let us observe cell structures smaller than 20 nanometres across.

Microscopy now allows imaging cells in living organisms

In the past two decades laser diagnosis and treatments in ophthalmology, dermatology and other medical fields have become standard procedures. Optical coherence tomography, for example, is now the gold standard for detecting morphological changes in the eye and has created a whole new market for retinal diagnostics and the diagnosis of glaucoma.

Biochips and optical methods for gene sequencing offer new routes to better diagnosis, thereby opening ways to optimise the treatment of cancer.

Fluorescence methods have replaced radiology in screening processes during drug development and have started to be used for in-vivo cancer diagnosis. For example, fluorescence-assisted exploration and resection have been used to precisely localise cancer cells in lymph nodes during surgery for breast cancer. This improves the outcome of the procedure and reduces the likelihood of further surgery for the patient. Fluorescence can also be used to image the migration of immune cells in live mice, promising future human applications in stem cell therapy and regenerative medicine. Fluorescence is also one of the methods employed successfully for functional imaging in order to gain a deeper understanding of physiological activities within a certain tissue or organ. Functional



Fig. 4.3.1 A surgical microscope being used for optimal vision in neurosurgery © Carl Zeiss

imaging together with metabolic imaging will help to decipher the set of chemical reactions that constitute the metabolism and thereby open the door to advanced therapies. The combination of diverse but complementary methods, including non-photonic methods, is seen as especially promising.

From an early stage European institutions and companies have played a leading role in photonics for healthcare and life science (biophotonics¹). European companies hold more than 30% of the market in this field, are net exporters and have an extensive R&D base within Europe. In Germany, for example, more than 80% of product value generation is within the country but more than 60% of revenues come from outside. Europe's excellent position has to be protected by constant innovation.

European companies hold more than 30% of the biophotonics market

Figure 4.3.2 United Nations world population forecasts

in billions Sources: U.S. Government Accountability Office (GAO), 2006 Revision

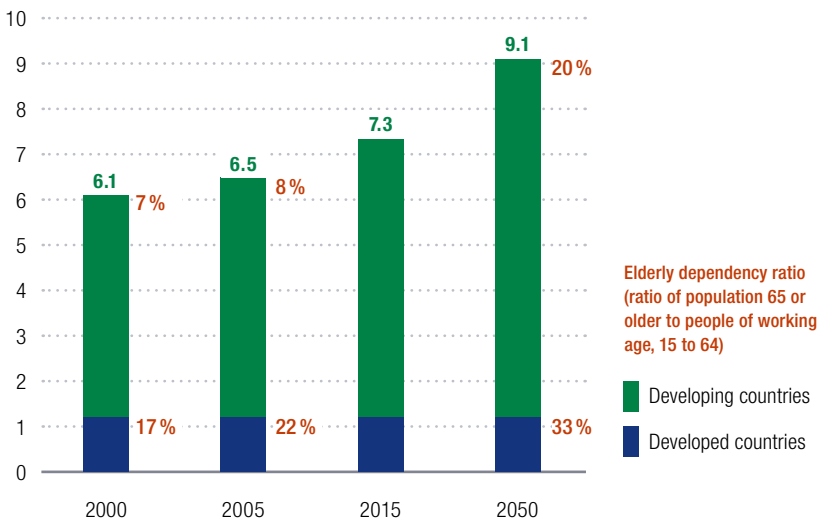

Driver of biophotonics industry and research: demographic change leading to a greying society

The main driver for the growing role of photonics in healthcare and life science is one of the major social trends: demographic change leading to an ageing society and in turn to drastic increases in healthcare costs and reduced quality of life. In developed countries the so-called elderly dependency ratio (EDR), the number of people aged 65 or more, expressed as a percentage of people of working age (15-64), will increase from 24% to 33% in the next forty years. Combined with a further strong population increase in developing countries, these changes will lead to an older society all around the globe and the associated immense costs for modern healthcare systems. Chronic and lifestyle-related diseases are also becoming more prevalent.

¹ Biophotonics is a multidisciplinary research area that utilises light-based technologies in medicine and life sciences. The vision behind biophotonics is to gain a full understanding of the origins and molecular mechanisms of diseases to either prevent them or, at least, diagnose them early and precisely, followed by a treatment which is specifically adapted to individual needs. Since human health is strongly influenced by external parameters such as food, water and air, monitoring and controlling their purity are also included in biophotonics research.

Figure 4.3.3 U.S. healthcare expenditures (1997 – 2017)

Sources: National Health Statistics Group; U.S. Department of Commerce, Bureau of Economic Analysis, WHO: Patterns of Global Health Expenditures, 2002

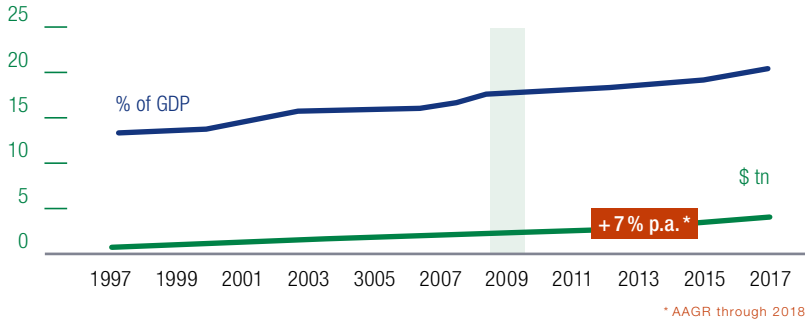

A paradigm shift is needed to reduce healthcare costs

Global spending on healthcare is estimated at \$5 000 billion a year, a substantial portion of the gross domestic product (GDP) in developed countries. In the U.S., spending on healthcare is expected to reach 20% of GDP in 2020. This trend holds true for European countries as well. Economic catch-up in developing countries will create further demand for cost-efficient healthcare solutions.

To contain or even reduce healthcare costs while maintaining quality of life, a paradigm shift is needed. Today, illnesses are treated according to the symptoms they present; in future, illness could be detected and cured before any symptoms appear. Ideally, the development of a disease will be averted by early detection. Photonics can play a major role in this area for the following reasons.

- Innovative microscopes and endoscopes will help us to understand cell processes, tissues and model organisms and so support the development of drugs tailored to a given patient. These are urgently needed for personalised medicine.
- Screening and medical imaging methods based on photonics will strengthen preventive medicine and the early detection of diseases.
- Non-invasive or minimally invasive treatments, such as therapeutic laser systems, will help to improve the health and mobility of patients and could lead to substantial cost savings.
- By combining microfluidics with photonics we can make ultra-sensitive 'lab on a chip' biosensors. These sensors can measure minute amounts of substances in small sample volumes, and make it possible to assess patients rapidly at the bedside.

Focus areas for optical technologies in healthcare and life science

Priorities for optical technologies in healthcare and life science should meet each of the following criteria.

1. The focus area addresses one or more of the main challenges associated with the ageing society, namely cancer, neurodegenerative diseases, cardiovascular diseases, ocular diseases and infectious diseases, especially sepsis.
2. The area of the body affected by the disease must be accessible to photons, i.e. is no deeper than a few centimetres beneath accessible body surfaces. Alternatively metabolic products in body fluids such as saliva, tears and urine can be investigated by photonic methods and can provide valuable information.
3. Photonic technologies can make a real difference in this area when compared with existing non-photonic technologies.

4. The focus area affects large numbers of people and will do so for the foreseeable future. A significant improvement in the quality of life or the safety of the patient can be expected, along with a major impact on society, substantial cost savings and a high market potential.
5. The focus area employs and strengthens an existing industry and research infrastructure within the EU.

Using these criteria, the following four main focus areas have been defined:

1. **Cancer** is one of the biggest challenges associated with the ageing society: in 2007 7.6 million people died of cancer and it is expected that this number will increase by 2% each year, to 17.5 million by 2050. With 12 million new cases worldwide every year numbers are expected to continue to rise sharply². Early detection of cancer is the key factor, since the earlier the detection the more likely a cure will be possible. A WHO study, for example, shows that 30% of all cancer cases could be cured if detected early enough. Photonic technologies are already applied relatively widely in laboratory testing for diagnosis, but their use for in-vivo diagnosis and treatment is limited to photodynamic therapy and to fluorescence endoscopy to detect tumour lesions during surgery. This is likely to change within the next few years since optical technologies offer clear advantages over established technologies such as X-ray and ultrasound: they have better resolution, are more specific and can produce results in real time. New diagnostic and treatment markets will emerge from innovative optical technologies, especially by the combination of existing photonic and non-photonic imaging methods such as positron emission tomography (PET).

Cancer is one of the biggest challenges



Fig. 4.3.4
A patient during an ophthalmologic examination © Fotolia

2. **Eye-related diseases** are another major problem directly related to the ageing society. Age-related macular degeneration (AMD) is the primary cause of severe loss of vision in people over 60. About 37 million people around the world are affected by AMD and this number will rise further as the population ages. Glaucoma is another leading cause of blindness, affecting around 65 million people today and more than 80 million by 2020.³ Since the eye itself is an optical system, the application of optical technologies in diagnosis and treatment is a quite natural and this market is already dominated by optical technologies.
3. Older people are more likely to need longer stays in hospital and more invasive surgical procedures. Therefore **sepsis** is common among elderly patients. As patients are often critically ill and have weakened immune systems, the disease is usually more severe

Eye-related diseases are another major problem in ageing societies

2 "Global Cancer Facts & Figures 2007", <http://www.cancer.org>

3 Market Scope, LLC, "The Worldwide Glaucoma and Retinal Diagnostic Equipment Market", April 2006

Sepsis is common among elderly patients

than in younger patients. In the U.S.A., sepsis is the second-leading cause of death in non-coronary patients in intensive care units, and the tenth most common cause of death overall.⁴ Sepsis affects 1 to 3% of hospital patients and its pathogenesis is often severe. In the U.K., for example, one out of three beds in intensive care units and hospitals is occupied by sepsis patients.⁵ In Germany about 154 000 patients fall ill with sepsis every year and more than half die as a result. About 20 to 35% of patients with severe sepsis die within the first month as do 40 to 60% of patients with septic shock, the more severe form of the disease. Even patients who survive the acute phase can still die from inadequately controlled infections, immunosuppression, complications resulting from intensive care as well the patient's primary disease or injury.

The unmet need in cases of sepsis is to diagnose the pathogen much faster than is possible with today's methods, including culturing and polymerase chain reaction (PCR), and, ideally, to obtain information about its resistance.

4. An understanding of processes in cells, tissues, and model organisms is a prerequisite for developing innovative solutions for early diagnosis and treatment. As a consequence, the **preclinical research** market covers a large variety of applications and products. From the holistic understanding of life processes down to the cellular and molecular level, there is a strong trend towards high-throughput cell sorting and gene sequencing systems calling for photonic technologies. Key requirements include high resolution in two or three dimensions, long-term and stable monitoring of molecular processes, and miniaturised laboratory tools. An understanding of cell processes on the molecular level is also needed for the concept of personalised medicine, where available genetic information, such as that obtained by innovative optical imaging systems, is used to tailor check-ups and treatment to the needs of individual patients.

Understanding cell processes is key to earlier diagnosis and treatment

Topics that may become more relevant in the future as more advanced biophotonic tools become available are neurodegenerative diseases, cardiovascular diseases, pharmaceuticals and food safety, the identification, isolation and characterisation of pharmacological agents, stem cell therapy and infectious diseases. Although not prioritised in this report as focus areas for the next few years, the technological challenges that currently limit the use of optical technologies in these applications will also be described in the section on preclinical research.

Overview of the biophotonics market

In 2008 the global healthcare industry was worth \$917 billion with a compound annual growth rate (CAGR) of 6%⁶. This market can be segmented into pharmaceutical products, biotechnology, and life science tools and services. As described above, major drivers of growth are demographic change, rising costs of healthcare and technical innovation. Biotechnology is growing at 10% a year and life science at 15%.

The market for optical healthcare equipment was worth €23 billion in 2007 and is expected to grow by 8% a year to €43 billion by 2015 (see Figure 4.3.5). This market includes eyecare systems as the largest segment, followed by microscopes, endoscopes, medical imaging devices, therapeutic laser systems and laboratory med-tech systems. The main eyecare products are spectacle lenses and contact lenses. The microscopy segment includes both laboratory and surgical microscopes. The endoscopy segment covers fixed and flexible endoscopes as well as components such as cameras and video

In 2008 the global health-care industry was worth \$917 billion

4 Centers for Disease Control and Prevention

5 Emergency Medicine Journal: EMJ, September 2006, 23(9):713-717

6 Datamonitor Studies 2009: Pharma, Biotech & Life-Science, Biotechnology, Pharmaceuticals, Life-Science Tools and Services

Figure 4.3.5 The global market for optical healthcare equipment

in billions of euros Source: BMBF Optische Technologien 2007, linear data extrapolation to 2015

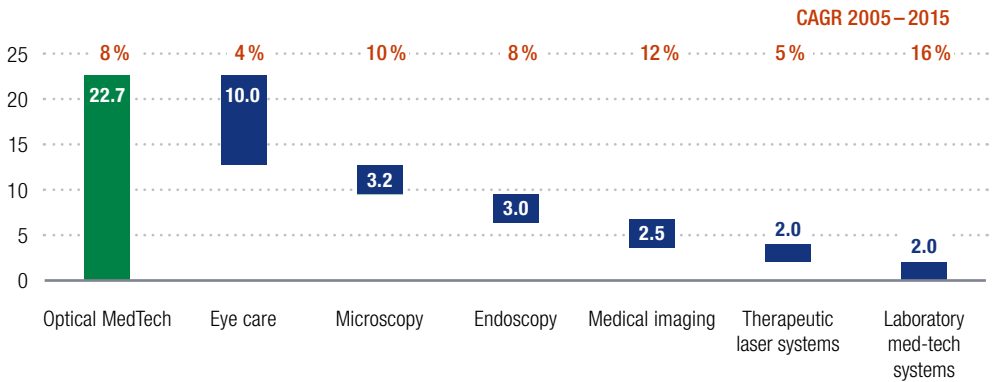

equipment. Medical imaging includes computed radiography systems, optical coherence tomography systems (such as those for diagnosis of eye-related diseases) and fluorescence diagnostic systems but excludes techniques such as X-ray and nuclear magnetic resonance (NMR). Examples of therapeutic laser products are refractive lasers used for eye surgery and photodynamic therapy (PDT) used for cancer treatment. The fastest-growing segments are laboratory med-tech systems and medical imaging.

Lee et al. estimated⁷ the biophotonics market to be worth \$53 billion in 2004 (projected to be \$107 billion in 2007) though they included techniques such as X-ray, PET and ultrasound in their analysis.

According to another study by Kalorama the global biophotonics market was estimated to be \$11 billion in 2006.⁸ The authors predicted a yearly growth rate of 31%, forecasting a market of \$133 billion by 2016. The study focused on microscopy and accessories and their application in the life science research market. The extraordinarily strong growth stems, the authors say, mainly from the development of applications. Basic research is seen as a minor factor. As the obstacles for entering the market are seen as low, the study predicts growing pressure from competition.

The cancer drug therapy market is huge with total revenues of \$47.3 billion in 2008 and an expected growth of 19% CAGR until 2013. The largest segments are target therapy (\$22.9 billion in revenue) and chemotherapy (\$14.3 billion).⁹ The market for photodynamic therapy (instruments and drugs) amounted to \$9 billion in 2007, of which drugs make up \$7 billion. The cancer diagnostics market is worth \$7.4 billion in 2009 with an anticipated growth rate of 11%, of which in-vitro diagnostics make up \$7 billion.¹⁰

The application of photonic technologies in cancer diagnosis and treatment mainly focuses on fluorescence endoscopy to detect tumours during surgery and on photodynamic

Cancer diagnosis and therapy market

7 "A Study of Biophotonics: Market Segments, Size and Growth", Gabriela Lee*, Kaiyi Chu, Lisa Conroy, Lauren Fix*, George Lui, Chris Truesdell, M.B.A. students and alumni, Consulting, Center at the Graduate School of Management, UC Davis, CA (M.S. in Biomedical Engineering, UC Davis), *Optik & Photonik*, June 2007, No. 2, p. 30 ff, © 2007 WILEY-VCH Verlag GmbH & Co. KGaA, Weinheim

8 November 2006, published by: Kalorama Information, A division of MarketResearch.com, 38 East 29th Street, New York, NY 10016, www.KaloramaInformation.com

9 BCC Research, "Cancer Therapies: Technologies and Global Markets", May 2008

10 Centers for Disease Control and Prevention U.S.A., 2008

therapy. Although optical technologies account for only a small fraction of the cancer diagnostics and therapy market, this share is expected to grow in the coming years. Optical technologies offer clear advantages over established technologies such as X-ray and ultrasound due to their better resolution, higher specificity and real-time capability. As a consequence, new segments of the huge cancer diagnostics and therapy market will emerge from innovative optical technologies that offer early diagnosis and gentler treatment.

Ophthalmic systems market

The ophthalmic diagnostics and surgical equipment market was worth \$7.5 billion in 2007 with anticipated growth of 9%, yielding a market of \$15 billion in 2015. Since the eye itself is an optical system, the application of optical technologies in diagnosis and treatment is quite natural and so this market is already dominated by optical technologies. The worldwide market for retinal and glaucoma diagnostics amounted to \$1.5 billion in 2008 and is expected to grow to \$3 billion by 2015. Another essential segment of the ophthalmic market, intraocular lenses, accounted for \$2 billion in 2008 and will reach \$4.7 billion in 2015 with a 13% annual growth rate.¹¹

Along with the use of photonics technologies for diagnosis and treatment of eye-related diseases, experts see tremendous potential and incipient markets for technologies that use the human eye as a 'window' for detecting other disorders such as diabetes and Alzheimer's disease (see page 103).

Sepsis market

So far photonic technologies have had very little impact in the sepsis market as the gold standard is the examination of pathogens via culture. PCR has been shown to be a much more effective method, but is still far from what is required with regard to speed and accuracy and has not yet been standardised. For these reasons the sepsis market is still regarded as a pharmaceutical market, and seen as high-risk because of the complexity and the many expressions of the disease. Nevertheless, due to the high number of cases and the gravity of the disease, photonic technologies have an immense potential, especially as accurate diagnosis will lead to much more effective and targeted treatment. The direct costs alone for sepsis treatment amount to €1.7 billion a year in Germany and \$4.5 billion in the U.S..

Figure 4.3.6
Segmentation of the ophthalmology surgical market 2008 (including diagnostics)

in billions of USD Source: Carl Zeiss (2009)

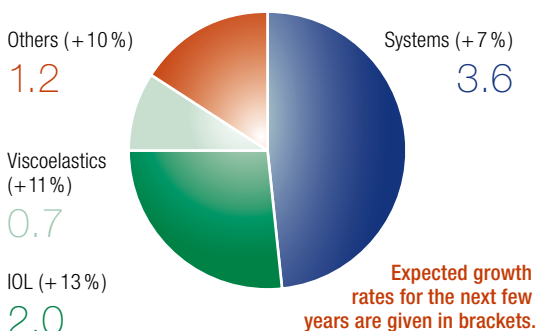

Segmentation of the ophthalmic systems market 2008

in billions of USD Source: Carl Zeiss (2009)

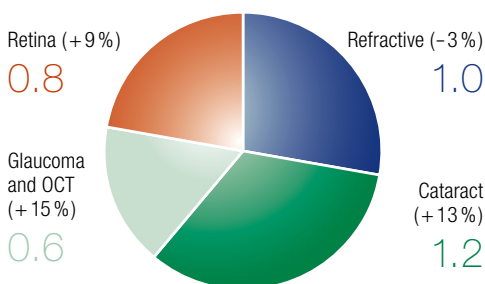

¹¹ Carl Zeiss, 2009

As mentioned above, an understanding of cell processes, tissues and model organisms is a prerequisite for developing innovative solutions for early diagnosis and treatment. Currently, the global market for instruments for life science research is estimated to be \$10 billion, with a growth rate of 7%.¹² Microscopy tools for biomedical research account for €1.2 billion at a growth rate of 5%. Life science research is also essential for the development of personalised medicine.

Life science
market



Fig. 4.3.7
Photonic technology (an endoscope) used during heart surgery
© Prof. Lichtenberg,
University Hospital, Jena

Europe's position

In 2008, European industries kept their leading position with a 30% share in the worldwide biophotonics market. Europe produced €5.7 billion worth of photonics for medical imaging and life science in 2005, representing 33% of the corresponding world market and 13% of the entire European photonics production.¹³

On a less aggregated level, European market presence ranged from more than 50% in light microscopy down to less than 20% in in-vitro diagnostics and medical imaging systems. Therefore, joint European research efforts and funding are strongly recommended in order to strengthen market positions and overcome weaknesses in some areas.

Over the past few years, biophotonics has developed into an autonomous scientific discipline which is still advancing rapidly. European industry, researchers and institutions are playing a leading role. Some of the most important trade fairs and biophotonics conferences are held in Europe, above all the LASER World of Photonics, where biophotonics is one of the key subjects, and the European Conferences on Biomedical Optics (ECBO), which is strongly coupled to the LASER. With about 500 scientific papers, ECBO is the world's second largest conference in the field after the BIOS conference, which is part of U.S.-based Photonics West. European researchers are significantly involved in BIOS as well, not only by contributing scientific papers but also by chairing conferences and as members of programme committees. Other European congresses generating worldwide interest include the annual meeting of the European Optical Society (Paris), which has a subconference on biophotonics, and Photonics Europe, which is organised by SPIE and is also connected to a trade fair. Moreover, one of the two

4.3.2

*Biophotonics
has developed into an
autonomous
scientific
discipline*

¹² Strategic Directions International, Inc., "Instrument Business Outlook", Vol. 17, No. 19, January 15, 2009

¹³ Optech Consulting, 2007. From the report "Photonics in Europe, Economic Impact", published by Photonics 21.

leading scientific journals dedicated to biophotonics, the *Journal of Biophotonics* (JBIO), is published in Europe.

Many governments around the world recognise the economic, scientific and social importance of biophotonics. Their funding programmes (Figure 4.3.8) are stimulating further advances in the field and strengthening competition between research institutions, regions and countries. With extensive funding, the United States and Singapore have established national research centres on biophotonics. These institutions are unparalleled in Europe, where biophotonics research is driven mainly by numerous research groups in university hospitals, universities and other research institutions. Interdisciplinarity – the close collaboration required in biophotonics between medical doctors, natural scientists and engineers – seldom occurs within these institutions, but is typically realised by cooperative efforts like research projects conducted jointly by medical and scientific institutes. National funding programmes have significantly driven such collaboration.

Fig 4.3.8
Biophotonics initiatives

Country	Project name	Main focus	Budget
The Netherlands	IOP Photonic Devices for Health & Medicine	<ul style="list-style-type: none"> • Imaging techniques, cancer diagnosis, molecular imaging, Raman spectroscopy, optical coherence technology, breath analysis, fluorescence microscopy, SPECT 	€25 million
Germany	Forschungsschwerpunkt Biophotonik	<ul style="list-style-type: none"> • Microscopy (3-D, high-resolution) • Spectroscopy • Optical micromanipulation • Cancer diagnostics • Cardiac infarction • Fine particulate matter • Germs in drinking water 	approx. €100 million (since 2002)
Scotland	SUPA	<ul style="list-style-type: none"> • Spectral imaging • Optical manipulation of molecules and cells • In-vivo sensing and imaging • Multi-planar imaging microscope • Micron-sized sources and nano-optics with single photon (quantum dot) sources and detectors 	approx. £14 million (first 5 years)
Ireland	NBIPI	<ul style="list-style-type: none"> • Molecular imaging • Live cell and histology imaging • 3-D reconstruction and stereology • Small animal in-vivo imaging • Human diagnostic imaging • Numerical and computational image analysis 	€30 million for 2007-2010
U.S.A.	NSF Center for Biophotonics	<ul style="list-style-type: none"> • Bioimaging • Cellular and molecular biophotonics • Medical biophotonics • Education and human resource development • Knowledge transfer 	\$52 million for the first ten years (2002-2012)

U.S.A.	Biophotonics for Life	<ul style="list-style-type: none"> • Create and foster a global consortium • Develop a worldwide network • Develop a strategic roadmap 	initially \$1.5 million
Japan	Large-scale research and development (R&D) projects initiated by the Ministry of Economy, Trade and Industry (METI), the Ministry of Education, Culture, Sports, Science and Technology (MEXT), and the Ministry of Health, Labour and Welfare (MHLW)	<p>Molecular imaging research programme:</p> <ul style="list-style-type: none"> • Imaging equipment for early detection of lifestyle-related diseases • Molecule imaging equipment for malignant tumour therapy support <p>Knowledge cluster initiative (e.g. Hamamatsu Optronics Cluster):</p> <ul style="list-style-type: none"> • Next-generation imaging devices, which feature a dynamic range of previously unattainable width and smart imaging, enabling efficient acquisition of only the necessary image information • Highly functional microscope systems, endoscope systems, and surgery support systems • Camera device for high-energy rays used in non-destructive inspection and X-ray CT 	approx. €20.5 million for 5 years (Start: 2005) ?
Canada	Biophotonics Initiative in the framework of the Network of Excellence, Canadian Institute for Photonic Innovations (CIPI)	<p>Biophotonics as one of three main focal areas:</p> <ul style="list-style-type: none"> • CellLab: The living cell as a laboratory • Advanced photonic technologies on a chip for single cell analysis • Two-photon excitation photodynamic therapy • Integration of digital micro-mirror devices with confocal macroscopy for improved genetic microarray reading and tissue imaging • Biophotonic systems using high resolution and diversity imaging • Improved femtosecond laser-based approaches for cellular imaging in live tissue 	C\$4.2 million for fiscal year 2006–2007
Australia	Research network for fluorescence applications	<ul style="list-style-type: none"> • Development of time-resolved fluorescence instrumentation for ultrasensitive microbial screening • Laser-based biochemical assays to instantly recognise heart attack • Extraction of commercially significant fluorescent proteins native to Australian reef corals • Specific microorganisms in complex environments such as industrial waste using high-level multiplex fluorescent probes 	A\$2 million (2004–2009)

Australia	Centre for Biophotonics and Laser Science (at the University of Queensland)	<ul style="list-style-type: none"> • Fundamentals of light-matter interactions • Biological imaging and sensing • Biological spectroscopy and devices • Laser manipulation • Biomedical and clinical applications 	?
Taiwan	Institute of Biophotonics, National Yang Ming University	?	?
Singapore	Biomedical Sciences (BMS), Biopolis initiative	<p>Institute of Bioengineering and Nanotechnology:</p> <ul style="list-style-type: none"> • Nanobiotechnology • Delivery of drugs • Proteins and genes • Tissue engineering • Artificial organs and implants • Medical devices • Biological and biomedical imaging <p>Singapore Bioimaging Consortium (SBIC)</p> <ul style="list-style-type: none"> • Mission: build a coordinated national programme of imaging research and bring together the substantial strengths in the engineering and physical sciences with those in the biomedical sciences. SBIC seeks to identify and consolidate the various bioimaging capabilities across research institutes, universities and hospitals. Its mission is also to foster closer collaboration in bioimaging amongst researchers and medical practitioners. <p>Four technology platforms have been identified for core research programmes:</p> <ul style="list-style-type: none"> • Optical imaging • Image processing and management • Small animal imaging with magnetic resonance • Development of chemical/biological probes <p>These technology platforms will be used to support research in areas such as cancer, metabolic medicine and regenerative medicine.</p>	<p>Biopolis 2003–2006: approx. \$570 million (infrastructure only) approx. \$600 million venture capital (via Agency for Science, Technology and Research – A*STAR)</p> <p>\$4 million</p>
China	Laser manipulation	<ul style="list-style-type: none"> • Optical brain imaging and neuroinformatics • Optical molecular imaging and systems biology • Digital life and biomedical informatics • Optical probes and nanobiophotonics • Multimodal biomedical imaging and tissue optics 	?

One example of such an initiative is the National Biophotonics & Imaging Platform Ireland. Its mission is to provide a structured research and training framework for Ireland's investment and infrastructure in advanced imaging applied to the life sciences. To that end it has strong partnerships with industry and brings together the twelve major biophotonics and imaging research centres in Ireland.

In Germany the government has launched a dedicated funding initiative to support the development of optical solutions for medicine and the life sciences (*Forschungsschwerpunkt Biophotonik*). Since 2002 more than 120 partners from science and industry have joined forces in collaborative projects. The initiative supports rapid embodiment of new scientific findings in marketable applications that benefit patients. Following up on project results, several products have already been introduced to the market, including an on-site monitor which can, within seconds, identify single, previously unknown bacteria in the air.

Despite these examples and other national initiatives in Ireland, the Netherlands and the U.K., major activities at European level are needed to keep Europe in a leading position. These will require adequate and closely targeted funding.

Close collaboration between academia and industry is needed to rapidly convert new scientific findings into products and services but this alone will not be enough. At the same time we need to support interdisciplinary efforts, an essential concept that is still not practiced as much as it should be. Funding must be employed to help scientists, engineers and biomedical end users (such as physicians and biologists) work closely together. This should also include suitable interdisciplinary education in the form of stand-alone courses or graduate schools. The aim is to ensure that future development of biophotonic tools and techniques will be purpose-oriented by basing that development on the specific needs of the end user.

The European Commission has taken a first step in this direction by funding a European project in biophotonics which aims to bring together clinicians, biologists, engineers, physicists and chemists and to help them undertake multidisciplinary work. This ensures that applications drive the development of technology (technology 'pull') rather than the more common experience of technology being 'pushed' into applications. In concert with closer collaboration with industry, this will help to further strengthen the leading position of the European photonics sector.

Funding must be employed to help scientists, engineers and biomedical end users work closely together

Technological challenges and research areas

4.3.3

Oncology

Cancer is one of the fastest-growing threats to people's health. Although it is a worldwide problem, it is a strongly age-related disease and so is of particular concern to Europe's ageing population. Early detection is a paramount factor for the progress of cancer, so prevention and early detection both have high priority. Unfortunately, screening is not yet possible for all forms of cancer, and for some it is either ineffective or unpleasant (such as colonoscopy). Thus a majority of the population does not benefit from screening at present.

Today's methods of cancer detection are often not specific or sensitive enough to lead to a conclusive result. It can be difficult to select a biopsy sample by the usual visual inspection, especially in the early stages of cancer or if the affected area is small. The standard biopsy methods cannot always scan the whole of the extracted tissue sample, which could lead to an erroneous finding, especially for inhomogeneous types of cancer such as astrocytomas (primary brain tumours).

Since fast and reliable detection methods are often lacking, treatment can be started without screening and biopsy, for example in cases of skin or breast cancer, where

Challenges

Fig. 4.3.9
Comparison of skin
cancer under white
and fluorescent light
© Prof. Katarina
Svanberg, University
Hospital, Lund

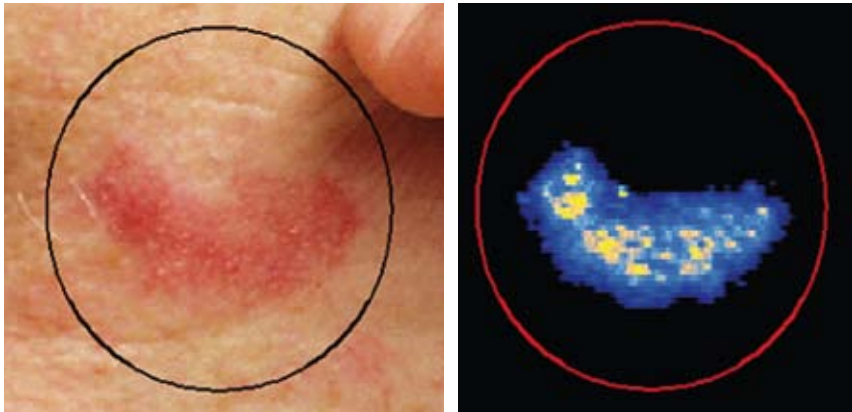

tissue is sometimes removed as a precautionary measure, without a precise diagnosis. As far as possible, screening and diagnosis should be minimally invasive and gentle on the patient. Diagnostics using ionising radiation should be kept to a minimum as some patients can develop cancer as a result. Certain genetic variations, such as the ataxia-telangiectasia (AT) gene, can multiply sensitivity to radiation by a factor of about 100.

Once a tumour is detected, it is of the utmost importance to determine its precise boundaries either before or during surgery, especially where it is not possible to remove tissue liberally, as is the case for brain tumours. Otherwise there is a risk of the cancer reappearing. In the case of basal cell carcinoma, a common type of skin cancer, fluorescence spectroscopy has revealed that clinically judged boundaries of the tumour can be unreliable and that neighbouring areas, which may not look suspicious to the eye, can also be malignant.

In summary, photonic tools and methods must be further developed to improve specificity and sensitivity for detecting cancer earlier and more gently and to allow their use for screening, staging, grading and delineation of tumours. While certain general features of tumours can be exploited for optical diagnosis, the challenge will be to find and clinically verify very tumour-specific, optically addressable signatures to reach the necessary levels of specificity and sensitivity.

In the treatment of malignancies it is desirable to employ techniques which are minimally invasive and have minimal side-effects. Ideally, that means being able to identify the boundary of the tumour as precisely as possible while it is being removed. If further treatment is needed, such as chemotherapy, it should be possible to individualise it for each patient to ensure the best possible outcome while keeping side effects to a minimum. Photonic technologies and methods will be the key to achieving these goals but they need to go substantially beyond their current state of development.

At a more fundamental level we need to understand the formation, growth and spread of cancer. Advanced methods of analysis are needed to reveal patterns associated with the onset and growth of cancer by uncovering cell type and signalling pathways, which might be best examined at the level of a single cell.

To understand the formation, growth and spread of cancer in cells and sub-cellular structures, we need new and advanced tools and techniques. Improved flow cytometry and microfluidic devices based on the different varieties of Raman spectroscopy, for example, could allow spectroscopic examination of single cells and so determine the type of cell unambiguously and help us to understand cell signalling.

*Photonic
tools and
methods are
needed to
detect cancer
earlier*

*Research
priorities*

Such fundamental understanding is a prerequisite for developing point-of-care technologies that could detect and identify a tumour based on the detection and quantification of certain molecular species.

A common technique is to attach 'marker' molecules to cancer cells to make them more visible. New and more versatile markers must be developed, but the process is expensive and time-consuming and can only be justified where marker-free methods cannot yet be applied. Markers are similar to pharmaceuticals and requirements for clinical approval are stricter than those for medical devices. The costs associated with research, development and approval are therefore high.

Marker-free imaging techniques such as infrared and Raman microscopy, Coherent anti-Stokes Raman Scattering microscopy (CARS), Stimulated Raman Scattering (SRS) and autofluorescence-based methods can detect cancer quickly and reliably. They must be further developed and improved, in particular at an application-specific level. This includes methods for identification and extraction of specific information from the complex signatures typically associated with such techniques when applied to the complex biological systems of tumours and their pathological processes.

Equipment for screening and diagnosis must become more usable and less invasive. Many types of cancer can be efficiently cured in their early stages so gentler optical screening methods would not only benefit patients, but would also avert costs for more expensive treatment and later care. In lung cancer, for example, the survival rate falls from 60% in stage 1 to 1% in stage 4. Diagnostic tools should also be able to distinguish between mere inflammation and precancer or cancer, and between benign and malign lesions.

In some cases biopsy will be unavoidable. To improve the specificity and selectivity of tissue diagnostics, existing techniques must be further developed or combined in a single instrument with multimodal and correlative imaging technologies. To meet rising demand, a high degree of automation will be required to reduce reliance on human labour at all stages, including sampling, recording and evaluation. This will require image-guided biopsy and computer-aided diagnostics.

Treating patients will require more radical but less invasive surgical procedures based on photonic methods. By reducing recurrences of cancer and avoiding side-effects on normal tissue, these will help promote rapid healing and avoid long stays in hospital. Here, externally triggered, image-guided therapy seems to be a promising therapeutic option.

Gentler optical treatments will benefit patients and save costs

Ophthalmology

There is strong evidence that early symptoms of age-related diseases — such as cardiovascular diseases, diabetes and neurodegenerative diseases like Alzheimer's — can be detected in the eye and not only within the affected tissues. One advantage of the eye serving as a so-called 'window' on the body is that it is easily accessible and optical diagnostic techniques are minimally invasive. For example, blood counts can be obtained from the tiny blood vessels on the retina and some diseases can be detected — due to tell-tale metabolic waste products inside the eyeball — before symptoms become apparent. Fluorescence lifetime imaging can be used to distinguish the naturally fluorescent molecules (fluorophores) associated with these products.

On the other hand the eye itself suffers from various age-related visual impairments that often lead to blindness, such as retinopathy or geriatric macular degeneration. With morphological and functional information gained from optical measurements these diseases could be diagnosed earlier and treated in a personalised way.

One challenge is to develop novel optical techniques, suitable for clinical use, that address the functional and metabolic state of the eye, such as multi-spectral and lifetime

Challenges



Fig. 4.3.10
Optical tomography of
the ocular fundus –
a quantum leap in retina
imaging © Carl Zeiss

imaging. These need to be clinically evaluated and used together with established and further refined methods for morphological characterisation, such as optical coherence tomography (OCT).

Another challenge is the fast and ultrasensitive detection of the light returning from an optically sensitive organ. This will require better software for the correlation, evaluation and storage of multidimensional and multimodal data, so that features can be extracted from noisy optical images.

New laser sources will improve minimally invasive therapies and surgical interventions for eye diseases.

Research priorities

A high priority is to combine various optical technologies to create tools that can deliver morphological and functional information in a single measurement. The complex data acquired from such multimodal imaging must be analysed and the extracted features must be correlated with the development of the disease and transformed into clinically useful information.

New and improved markers and enhanced (sensitive, highly specific and quantitative) detection of marker fluorescence and of endogenous fluorescence will strengthen the portfolio of imaging technologies available for research, for screening and diagnosis, and for the monitoring and control of therapy.

Adaptive optics for imaging of the retina and other structures in the eye could improve resolution down to the cellular level. By correlating such data with morphological and functional information we will better understand the pathogenesis of eye diseases. It could also lead to more sensitive detection and earlier diagnosis of disease.

For surgery to the front of the eye, the development of femtosecond lasers specialised for medical treatment together with real-time optical methods for improved therapy control could further reduce irradiation times of the sensitive retina and improve the accuracy of procedures.

Sepsis

Challenges

Second only to improved hygiene in hospitals, the battle against infectious diseases relies first and foremost on rapid identification of pathogens and the determination of their resistance. This is particularly relevant to sepsis, which kills 150 people a day in Germany alone.

The first hour after the onset of sepsis is critical. In that time the hospital-borne infection must be detected, localised and examined, the microbiological findings

interpreted and an appropriate therapy started, otherwise mortality increases drastically, to 50% and above.

Yet the gold standard for diagnosis remains blood culturing, which takes 36 hours to deliver results and yields correct positive results in only 17% of all cases. The more recent alternative, PCR analysis, takes six hours and is two to three times more accurate. Neither of these is fast or sensitive enough to differentiate reliably – within the first hour – among the many different pathogens (bacteria or fungi) that can cause sepsis.

Photonic point-of-care diagnostic tools combined with PCR may be able to identify pathogens within 30 to 60 minutes and detect resistances to certain antibiotics so as to adapt therapy in a personalised and reliable fashion ('theranostics'). If clinicians know the mixture of pathogens characteristic of 'their' clinic before the outbreak of sepsis, an even faster diagnosis is possible. The individual composition of pathogens could be determined from pathogenic biofilms precipitated from ambient air before sepsis occurs and information about possible resistances can be gained.

Photonic tools and methods must be further developed and combined with advanced microfluidic technologies and devices to develop a fast (30 to 60 minutes) and reliable method to differentiate between the various pathogens that might be responsible for the infection. Ideally the photonic point-of-care diagnostic instrument would be combined with PCR to detect resistances to certain antibiotics and to adjust therapy according to the result. This would allow individualised treatment and could drastically cut the mortality rate. Another challenge is to develop fast and automated tools or devices for the examination of pathogenic biofilms, which could allow the composition of pathogens characteristic of the individual clinic to be determined and also help with hygiene control.

Research
priorities

Preclinical research

The ultimate challenge in preclinical research is to develop photonic tools and methods that help us gain a holistic understanding of life processes on the cellular level. This requires continuous observation on all scales from organs and tissues down to the cellular and even sub-cellular level. The corresponding tools and methods must be non-invasive to allow for observation without changing or disturbing the processes to



Fig. 4.3.11
Microscopic
examination of
transdermal drug
forms © Bayer
HealthCare AG

be observed. Observation should be possible in real time, as storage or processing of all the data obtained should also be.

Knowledge gained from the topics described in this section will also benefit clinical research.

An important area of preclinical research, which is increasingly being transferred back to universities and research institutes, is screening candidates for new active agents such as pharmaceuticals. Here the basic challenges are to speed up the screening process and improve handling procedures such as sample preparation.

Another challenge is to meet the special needs of particular applications in preclinical research with instruments that can be used to study a wide variety of problems. These needs range from special geometrical requirements and supporting tools (such as sample preparation, loading and holding) through particular imaging modalities to adapted software solutions. The needs of researchers can change quickly, so photonic tools need to be adaptable to meet future demands.

Challenges

- **Cardiovascular diseases**

Due to growing wealth and globalisation, cardiovascular diseases are expected to be the number one cause of premature death by the year 2020. Basic research is necessary to better understand immunoreactions and the mechanisms of inflammation and to develop diagnostics and therapy. To that end, microscopic tools and the associated software have to be developed to enable in vivo imaging within heart tissue and inside pulsating arteries, at increased penetration depth. That will help us understand interactions between cells, identify micrometre-scale structures in arteries and perform functional assays in-vivo. For heart surgery, endoscopes must be improved to give the surgeon a wider field of vision (not just in the forward direction), to provide more information about depth, and to solve seemingly trivial problems such as the fogging of lenses.

- **Neurodegenerative diseases**

Most neurodegenerative diseases such as Alzheimer's and Parkinson's diseases arise from very complex metabolic mechanisms and generally correlate strongly with the age of the patient. It is well known that these diseases are caused by aggregation of certain proteins, but the exact mechanisms of aggregation and the factors that accelerate, prevent or stop it are not fully understood. Photonics and spectroscopy could become valuable tools for in-vitro studies of protein aggregation, especially if single molecules can be detected. Fluorescence methods, such as FRET, are specially promising here due to their angstrom-scale sensitivity which can detect protein misfolding and aggregation at very early stages.

Knowledge gained from in-vitro examination may also be employed to develop in-vivo technologies for the early identification of affected areas of the brain. To that end, tools for non-invasive (or at least minimally invasive) functional imaging of the brain would be necessary. This is a challenge since optical methods are well adapted to dynamic neuronal imaging but brain tissue is relatively opaque to light.

Basic research is needed to better understand cell organelles (such as the Golgi apparatus) and to identify where neuron targeting is disturbed. Electron microscopy is a useful tool but needs fixed cells and time-consuming sample preparation, both of which limit its value. So-called correlative microscopy, which combines the features of light and electron microscopy, is promising, as is high-resolution dynamic imaging by optical microscopy. It may also be possible to use multiphoton microscopy to detect and monitor small molecular probes that are able to cross the blood-brain barrier.



Fig. 4.3.12
Cardiovascular diseases
will increase over the
next decade © Fotolia

- Identification of pharmacological agents

Since the optimal dose of a drug and its potential side effects strongly depend on individual factors (the amount of the drug needed to achieve the same effect can vary tenfold between patients) it is highly desirable to measure the concentration of the drug at the target organ. This would assist in both personalised therapy and drug development.

Current detection methods such as liquid chromatography coupled with mass spectrometry are time-consuming and complex. Here, photonic point-of-care instruments could provide more flexibility and help to monitor the concentration of agents in blood, whilst the ultimate goal would be to develop a photonic technique to monitor ultralow concentrations (ng/ml) of agents in the target tissue. Sources of bioactive agents could be microbes isolated using optical tweezers. Optics is a key technology for isolating single microbes, which might be impossible to culture, and monitoring the bioactive compounds they produce.

- Safety of pharmaceuticals and food

From developments over the past few years we can expect many more newly developed products from the pharmaceutical industry, especially monoclonal antibodies, vaccines and endovenous liquids. These new pharmaceuticals demand better control of the preparation process, improved detection, quantification and identification of protein aggregation, and better environmental monitoring, which optical technologies could deliver in the future.

In the food industry, quality management must be further improved, including the detection and identification of single microorganisms as well as measuring their concentrations.

- Stem cell therapy

Advanced photonic tools and methods could help ensure the success of cell replacement therapy by tracking cells and analysing their differentiation. In case of a heterotopic transplant they could also monitor the survival rate of transplanted cells and determine

*Photonic
point-of-
care tools
could help
to monitor
agents in
blood*

Photonics can substantially advance cell replacement therapies

whether transplanted cells migrate to the damaged area, especially where cells cannot be labelled or destructively tested.

Non-photonics approaches like magnetic resonance tomography (MRT), computed tomography (CT) and sonography all have specific problems such as injurious radiation and the disproportionate time and cost needed to obtain findings. Again, the challenge of using photonic tools for in-vivo investigations is to penetrate the tissue of interest without losing the cellular level of observation.

For in-vitro work, photonic tools and methods could help control the isolation and culture of cells and to analyse cell differentiation. They could also be used in-vitro for optical selection and activation of specific cells and (possibly) in-vivo after transplantation. Using the cells' own natural properties without having to label them would be a huge step forward in identifying and processing cells for transplanting into a patient.

Photonic techniques can be invaluable in regenerative medicine for the design and testing of biocompatible materials and drugs related to the migration, division, interaction and differentiation of cells. In-vitro expansion of progenitor cells (such as from umbilical cord blood), whilst monitoring them to ensure they stay 'stem like', is of great importance because stem cells are so few in number when harvested from patients.

Research priorities

For a holistic understanding of life processes down to the cellular level it is essential to extend the performance of optical and spectroscopic methods far beyond their current limits. This means higher spatial resolution (submicrometre to a few nanometres) in both the axial and lateral dimensions of the microscope together with major improvements in sensitivity, specificity and contrast. This will permit non-destructive 3-D microscopy of living cells in their natural context with molecular-scale resolution, high dynamics (many frames per second) and high depth-penetration.

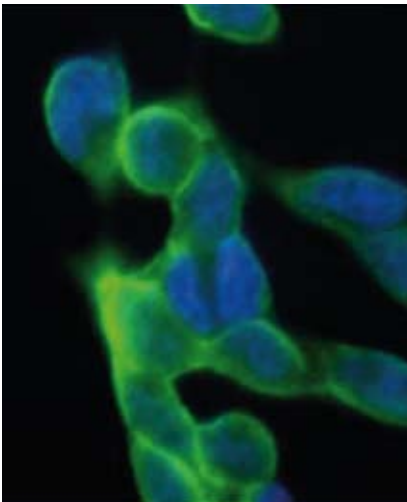

Fig. 4.3.13
Fluorescent transporting proteins in human HEK cells © Prof. Fromm, University of Erlangen

On the technology side the ultimate goal in preclinical research is therefore to expand the 'triangle of compromises':

- speed: detection in 3-D and in real time (30 frames/s), higher throughput, high-content screening, real-time processing, automation;
- resolution: filling the gaps between the macro, micro and nano scales, handling of large amounts of data;
- increasing sensitivity and specificity, higher penetration depths.

New tools and approaches will have to be developed which are less invasive (preferably not invasive at all) with better molecular contrast, higher sensitivity, specificity and precision, and which can yield results on time scales commensurate with biological processes.

These tools or techniques need to be able to process larger numbers of samples using methods adapted from other fields, such as high-throughput, array-based techniques for cell-based assays and rapid imaging and metrology tools for in-vivo studies. The tools must be independent of markers and dyes or at least use them in lower concentrations.

To meet the requirements of biomedical researchers, the next generation of photonic devices will have to be multifunctional or multimodal tools, combining different optical, biological and medical techniques and providing readout for multiple parameters. In addition, photonic tools will be used to culture, isolate and distinguish different types of cells in a non-contacting and therefore gentle and non-destructive way. Similar progress

has to be made with the software employed to control photonic tools and to analyse and evaluate the correspondingly larger amount of resulting data. Further technical challenges are to increase penetration depth of imaging while keeping high 3-D resolution, to miniaturise point-of-care applications, and to improve the signal-to-noise ratio.

For the screening of active agents, better screening platforms have to be developed, with improved sample handling and higher throughput rates. For example:

- microscopes for automated, high-throughput screening (downscaling multiwells, parallel analysis through area sensors, faster scanning, etc.) employing 'biophysical' techniques (FRET, TIRF, FLIM, FRAP);
- miniaturisation of microscopes (modular minimal microscopes), increased flexibility;
- refined analytical tools to investigate morphology;
- screening platforms should allow analysis of the slow processes of cellular plasticity including cell growth, migration, communication and differentiation. Active optical stimulation and control should also be possible to detect subacute toxicity. ●○○

The next generation of photonic devices will have to be multifunctional or multimodal tools



Fig. 4.3.14
Powerful biophotonics tools include microscope imaging and confocal laser microscopy
© Leica Microsystems

Contributors to the Working Group 3 user workshops for the preparation of the Photonics21 Strategic Research Agenda: Prof. Dr. med. Michael Bauer, Dr. Georg Bison, Dr. med. Marcus Blum, Prof. Dr. med. Jürgen Brockmoeller, Dr. med. Frank Martin Brunkhorst, Dr. med. Jens Dawczynski, Prof. Dr. med. Martin Fromm, Prof. Dr. med. Andreas Habenicht, Prof. Dr. Knut Holthoff, Prof. Dr. med. Christian Hübner, Dr. Markus Lankers, Prof. Dr. med. Artur Lichtenberg, Dr. Klaus Neef, Prof. Dr. med. Axel Niendorf, Prof. Dr. med. Wolfgang Pfister, Prof. Dr. Michael Schäfer, Dr. med. Christoph Schimpfennig, Dr. Ing. Oliver Schlüter, Dr. med. Carsten Schmidt, Dr. Ing. Dietrich Schweitzer, Dr. Ing. Mario Stahl, Prof. Dr. Alexander Storch, Prof. Dr. med. Katarina Svanberg, Prof. Dr. med. Otto W. Witte.

Management summary: Healthcare and life science

Market overview

Healthcare

- €23 billion market for optical technologies
- Growth to €43 billion at 8% CAGR by 2015
- Double-digit growth predicted in microscopy, medical imaging and laboratory med-tech systems sectors
- Global healthcare expenditures will rise by a factor of 2.8 between 2005 and 2020
- Oncology: PDT instruments and drugs market was \$9 billion in 2007
- Ophthalmology: market for ophthalmic systems is worth \$3.6 billion at CAGR 7%
- Cost-reduction potential of 20% anticipated by application of photonic technologies¹⁴

Life science

- Entire biophotonics market exceeds \$100 billion
- Life science research market \$10 billion in 2007
- Light microscopy in biomedical research market worth €1.2 billion in 2008 at moderate CAGR of 5%

Europe's position

Healthcare

- People employed in European med-tech industry: 30 000
- Turnover of the European med-tech and life science industry: €5.7 billion in 2005 representing 33% of the world market

Life science

- Strong European presence in light microscopy with 50% market share
- Weakness in the area of medical imaging systems and in-vitro diagnosis with less than 20% of the world market, representing a strong threat

¹⁴ Photonics21, Working Group 3 estimate

Focus areas	Oncology	Ophthalmology	Sepsis	Preclinical research
Challenges	<p>Solutions for minimally-invasive screening and diagnosis (incl. staging and grading)</p> <p>Interactive therapy control</p>	<p>New laser sources for treatment</p> <p>New methods for functional and metabolic mapping</p> <p>Fast and ultrasensitive detection</p> <p>Handling and processing large amounts of data</p>	<p>Methods and tools to identify pathogens</p> <p>Chemometric analysis</p>	<p>Application-specific but flexible research tools</p> <p>Imaging with high penetration depth and high 3-D resolution</p> <p>Multiscale tools (macro, micro, nano)</p> <p>Miniaturisation and coupling to analytical methods for point-of-care applications</p>
Research priorities	<p>Marker-free techniques (e.g. autofluorescence, Raman, CARS) and methods for identification and extraction of specific information</p> <p>New markers for cancer for earlier and improved differential diagnosis</p> <p>Optical biopsy exploiting multimodal microscopy approaches</p> <p>Point-of-care solutions including computer-aided diagnosis</p> <p>Less invasive surgical procedures</p>	<p>Multimodal techniques with optimised sensitivity and specificity for the combination of morphological and functional information and methods for feature extraction</p> <p>New markers and improved use of autofluorescence</p> <p>Cellular resolution for addressing fundamental research issues and for more sensitive detection</p> <p>Improved femtosecond laser treatment</p>	<p>Point-of-care devices for the identification of pathogens in body fluids and as biofilms</p>	<p>High-resolution imaging of living cells in their natural context (penetration, dynamics)</p> <p>Automated solutions including high-throughput, array-based techniques</p> <p>New optical markers and associated techniques</p> <p>Multimodal imaging including optical stimulation and control</p> <p>New and improved point-of-care modalities</p>

4.4

Lighting and displays

4.4.1

Market overview, main drivers and challenges

Introduction to lighting

The invention of the incandescent light bulb in the nineteenth century ushered in the era of artificial lighting. Since then, the conversion of energy into visible light at higher efficiencies and greater brightness has been the aim of major research and development efforts within both academia and industry. Gas discharge lamps, introduced in the middle of the twentieth century, presented the first step towards more efficient lighting, but cannot be fully customised for shape, colour or colour rendering.

The next revolution in lighting is now under way: solid state lighting, or SSL for short. This technology is based on electroluminescence by organic and inorganic semiconductors.

Inorganic light-emitting diodes (LEDs) started their breakthrough in the lighting arena about a decade ago. Initially they were only used for signalling or to illuminate mobile phone keypads. But due to their ever-increasing brightness and efficiency LEDs are now appearing in far more demanding applications such as automotive headlamps.

For lighting purposes, diode lights have outstanding properties. They include robustness, a very long lifetime, options for colour changing, dimming and instantaneous switching. These are the main drivers behind the tremendous improvement which has been made in just a few years. It is expected that LEDs will ultimately be able to outperform all other conventional light sources.

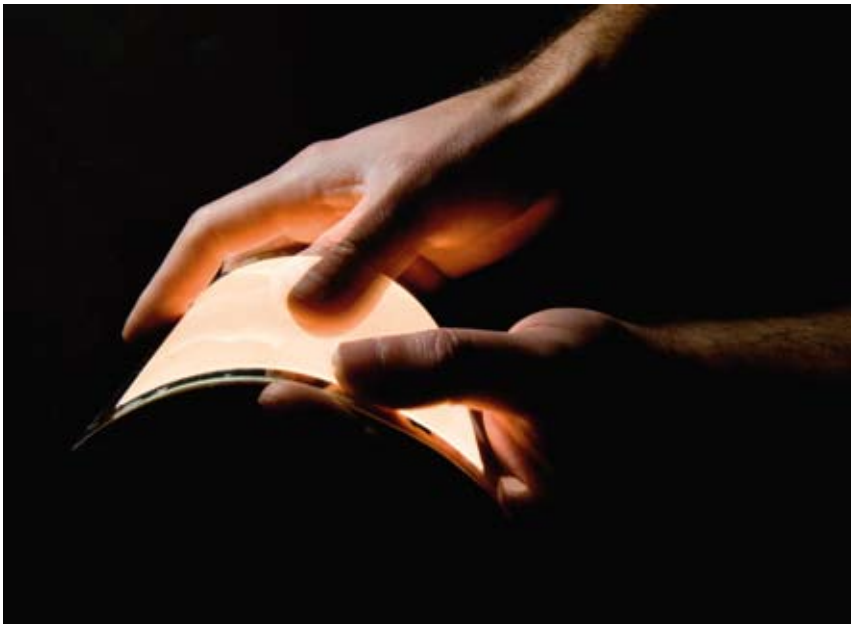

Fig. 4.4.1 OLEDs provide potential for power-efficient, large-area, warm-white light sources with revolutionary properties © Holst Centre/IMEC



Fig. 4.4.2
LED floodlight
illuminates the Lagoa
Martiñez complex
in Puerto de la Cruz,
Tenerife © Philips

LEDs are typically point sources, the perfect complement to another new lighting technology appearing on the horizon: organic LEDs (OLEDs). These are flat and diffuse, large-area light sources based on organic light-emitting molecules. R&D reports show that efficiencies of 50 lumens per watt (lm/W) or more have already been achieved in white-emitting OLEDs¹, augmented by unique lighting features: flexibility and transparency.

Lighting is a global market. In 2007 the lighting market reported €58 billion in turnover. About 63% was accounted for by luminaires, the remaining 37% by components, including all kinds of lamps, LED modules and electronic controls and drivers.

Lighting is also a growth market. In a recent paper based on historical and contemporary data spanning three centuries, six continents, and seven orders of magnitude,

Global lighting
market growth

Figure 4.4.3 Segmentation of the global lighting market 2007

Total: 58 billion euros Source: Philips Lighting, Strategy Overview, November 2007

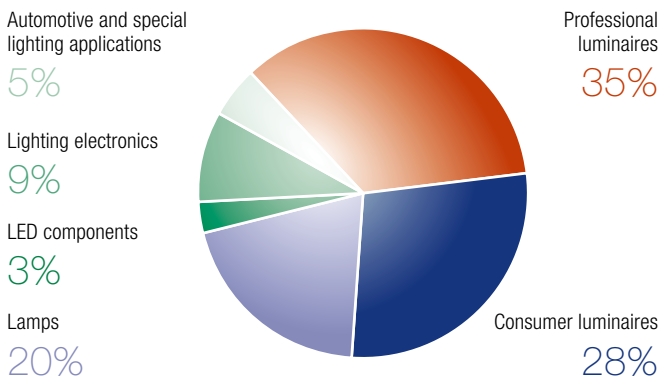

¹ The IST-OLLA project (2008), www.olla-project.org

Tsao and Waide² came to the conclusion that the consumption of artificial light is a linear function of the ratio between GDP (gross domestic product) and the cost of light. Over the last decade the demand for artificial light grew at an average rate of 2.4% a year³. The growth was slower in the IEA (International Energy Agency) member countries (only about 1.8%) than in the rest of the world (3.6%).

An average global growth rate of 2.4% will raise lighting consumption by a factor of 1.4 by 2020 and 2.9 by 2050. Lighting applications already consume 19% of all electrical energy produced. Only by adopting innovative lighting solutions will it be possible to produce more light in a sustainable way. That is why in 2009 the European Commission issued a ban on inefficient incandescent lamps.



Fig. 4.4.4 LED lighting offers new design and form options, as well as new ways to reduce energy consumption © Philips



Fig. 4.4.5 Ingo Maurer, 'Early Future', OLED lamp marketed in 2008 © OSRAM Opto Semiconductors

European market position

In both of the conventional technologies, incandescent lamps and discharge lamps, European institutions and companies played a leading role from an early stage. As a result, the two major players in the lighting industry have a strong R&D and production base in Europe. This is an excellent starting position for Europe's taking a global leading role in SSL but that position will have to be secured by constant innovation.

There are numerous players in the lighting industry in Europe, from LED manufacturers to makers of lamps and luminaires and several suppliers of materials, equipment and electronics.

According to the ELC (European Lamp Companies Federation) and CELMA (Federation of National Manufacturers Associations for Luminaires and Electrotechnical Components for Luminaires) the lighting business employs more than 150 000 people in Europe, generating a turnover of around €20 billion.

LED lighting market growth

The market for high-brightness LEDs reached \$5.1 billion in 2008 and is expected to grow to \$14.9 billion in 2013⁴. In recent years much of this growth has been driven by the increasing use of high-brightness LEDs in mobile applications such as mobile phones and digital cameras, though this is expected to stabilise. With the appearance of LEDs in new applications such as automotive headlights, the market will grow

2 Jeffrey Y. Tsao and Paul Waide, *Nature*, July 21 2007

3 "Light's Labour's Lost — Policies for Energy-efficient Lighting", International Energy Agency (2006)

4 Strategies Unlimited, "High-Brightness LED Market Review and Forecast 2009", Report OM-50,2009

Figure 4.4.6 The market growth for high-brightness LEDs – LED summary forecast by application

Revenues in billions of USD

Source: Strategies Unlimited, High-Brightness LED Market Review and Forecast, Report OM-50, August 2009

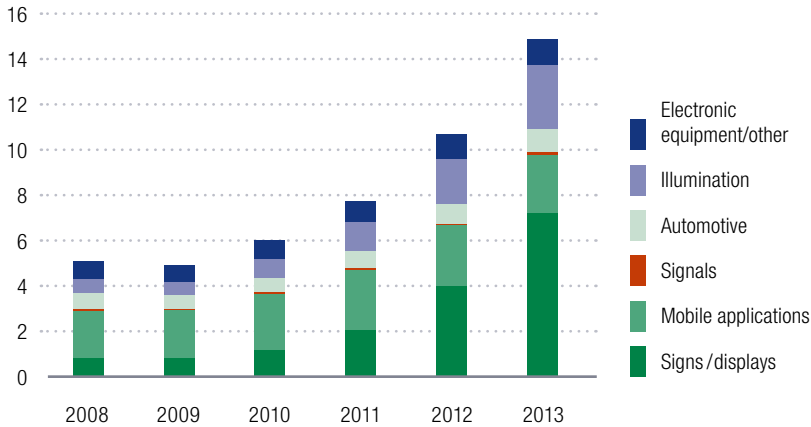

continuously up to 2013. The highest growth rates are expected in the market for signs and displays, with LEDs now being used as new sources for backlighting for laptops and LCD TVs (Figure 4.4.6).

The biggest boost to the LED market, however, is expected to occur when LEDs emerge into the general lighting market, the 'megamarkets' of the future. As LEDs are completely different light sources this also has consequences for the luminaire manufacturers. The luminaire market, which is dominated by SMEs, accounts for more than 60% of the overall lighting market and is today worth €36 billion. It is expected to grow by more than half again and exceed €56 billion by 2015.

The transition to LEDs will start relatively slowly but will then rise rapidly to reach a total market of \$5.3 billion in 2012 with a high CAGR of 28.5% (Figure 4.4.7). Residential and outdoor lighting will show the highest growth rates. The European lighting industry

Figure 4.4.7 LED fixture application forecast

Revenues in billions of USD

Source: Strategies Unlimited, LED Lighting Fixtures, Market Analysis and Forecast, Report OM-45, January 2009

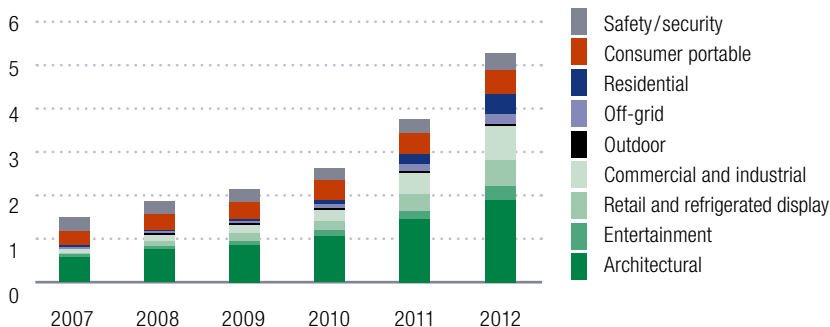
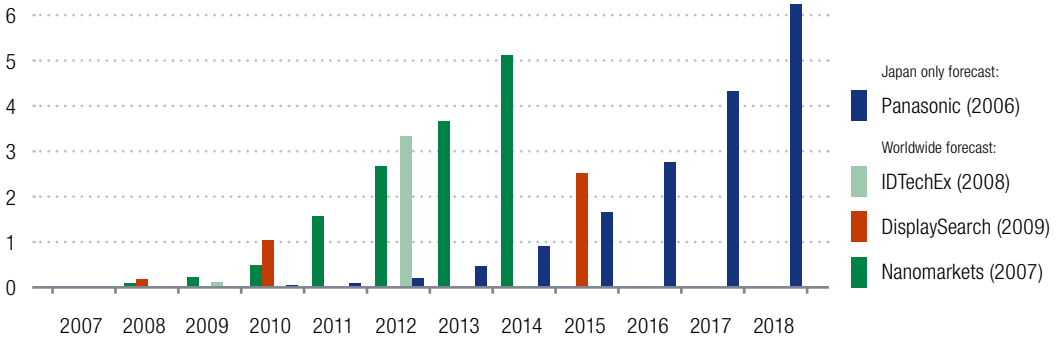

Figure 4.4.8 Predictions about OLED lighting from several perspectives

in billions of USD Source: cintelliq, DisplaySearch 2009, IDTechEx PR 2008, Nanomarkets Report 2007, Panasonic PE2006



is set to defend and even extend its world lead by quickly pushing the transition to SSL and so create highly skilled jobs for Europe.

Emerging
OLED lighting
market

The market for OLED lighting began in 2008 with the introduction of the first European OLED designer lamp by Ingo Maurer, based on OLEDs made by OSRAM Opto Semiconductors. Since then, smaller quantities of OLED 'light tiles' have been produced by Philips Lighting for demonstration and application studies, to pave the way for more OLED lighting products in the near future. The reactions to these early samples of this new light source have been positive, but at the same time the expectations for this novel, flat light source are very high.

Market studies of OLED lighting predict a differentiated but strong growth for the next few years towards a predicted €4 billion market in 2016, equalling about 5% of the total lighting market. Inorganic LEDs have already achieved a 5% level of market penetration and this can be considered as the 'point of no return' for market acceptance. Besides a massive R&D effort, this will require high investments in scaling up production platforms (which are also still under development) as well as in marketing and sales.

A paradigm
shift is need-
ed along the
whole value
addition chain

It is widely expected that many more OLED lighting products will be commercialised from 2010 onwards, targeting demonstrations and special niche markets which are less sensitive to price. From this starting point, the OLED market will gradually spread into general illumination, with stronger growth once the efficacy and cost levels become comparable with fluorescent lamps.

Several cycles of research and development will have to elapse before the market will be offered cheap and efficient OLED systems for general applications. The history of lighting has taught the industry that such a transition will take a long time, and that several types of lamp will co-exist for some decades. But the phasing out of less efficient lighting, such as incandescent and high-pressure mercury lamps, will help shorten this transition and offer Europe an excellent opportunity to strengthen its already strong lighting industry.

Solid-state
lighting
challenges

If LEDs and OLEDs are to reach high market penetration, the biggest challenges are to improve quality and performance while reducing cost.

Apart from the technological problems, the biggest organisational issue will be to manage the paradigm shift across the whole value addition chain. It must be stressed that SSL is a completely different light source from today's products and all the stakeholders will have to learn to adapt quickly. Luminaire manufacturers need to shift their



Fig. 4.4.9 Newer display technologies enhance the visual experience and save energy in operation and at stand-by © Philips

focus towards driver electronics and thermal management, installers need to be trained in control systems, light designers and architects need time to explore the many new opportunities offered in terms of forms. And last but not least, end users need to understand what SSL can offer in terms of energy consumption and total cost.

The new SSL lamps can be dimmed and their colour adjusted. Broad-based demonstration campaigns and acceptance studies are needed to examine the effects on health, well-being and productivity.

In modern societies, display technologies play a prominent role in communication, education and entertainment.

Television sets were first marketed more than sixty years after the first cathode ray tube (CRT) appeared. Flat-panel displays (FPDs) meanwhile are replacing CRTs in the majority of applications such as laptops, computer monitors and television sets. Today, nearly 70% of all TV sets sold incorporate an FPD. Only in emerging markets such as China, Africa and Latin America are CRT televisions still being sold.

Displays play a key role in communication-based societies

Figure 4.4.10 Split of the flat panel market by technology

in billions of USD Source: DisplaySearch 2009

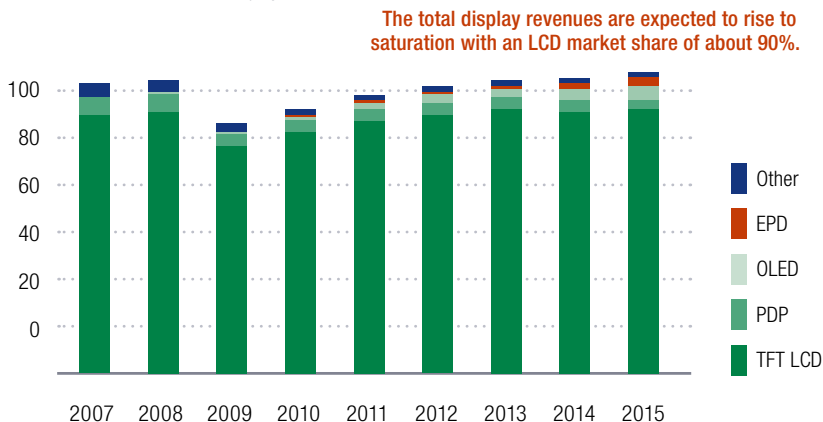

Fig. 4.4.10 Thin film transistor liquid crystal displays (TFT LCD), electronic paper displays (EPD), plasma display panels (PDP), organic light-emitting diodes (OLED)

Although in the past the majority of CRTs were produced in Europe, most display panels are now produced in Asia. In Eastern Europe some TV sets are still being produced using imported panels, accounting for about 30 000 jobs. On the other hand, Europe has established a strong presence within the markets for materials or devices used for displays (Merck, CDT and so on) and production equipment (such as Aixtron and Applied Materials).

Figure 4.4.10 makes it clear that the world market for FPDs will stabilise at turnover of about \$100 billion.

The thinness of LCDs offers very attractive prospects, especially when coupled with LED backlighting, for TV sets and notebook PCs.⁵ This application will also boost revenues for high-brightness LEDs.

The next and very promising flat-panel display technology will be based on OLEDs. OLED displays combine the best properties of LCD and plasma displays in terms of size, switching speed, viewing angle, colour gamut and energy efficiency. Unlike LCDs, OLED displays do not need a backlight, as the pixels produce their own light. They are even thinner than LCDs and can be printed on films to make flexible and unbreakable applications. Several Asian players have already shown OLED displays up to 15 inches and announced larger TV screens by 2010.

The market for OLED displays is expected to remain below \$10 billion until 2015⁶ with most value coming from smaller displays such as those for mobile phones. After 2015 OLED-TV is expected to become the application generating the largest revenue.

Emerging
new display
markets

However, this view on displays is less encompassing than it might be for European technology development. In the recent past several new display markets have emerged: signage and information displays in metropolitan spaces, advertising in retail premises and new mobile display formats such as e-paper for electronic books. Certain types

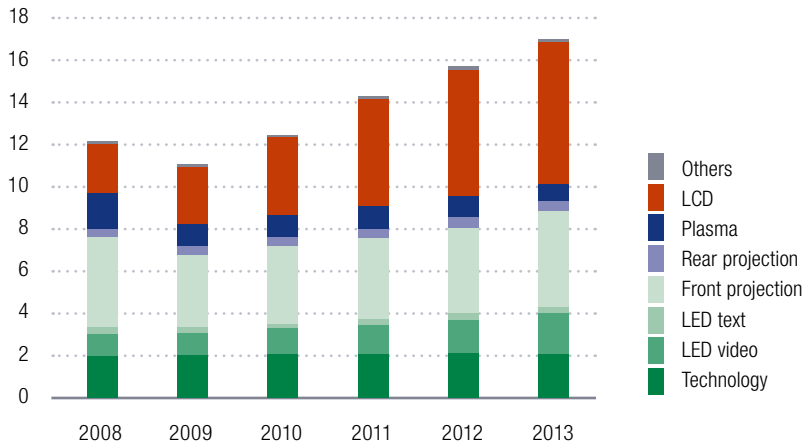

Fig. 4.4.11
Novel displays
enhance the concert
experience during
the recent U2
360° Tour © Barco

⁵ SID Symposium 2009, San Antonio

⁶ DisplaySearch 2009

Figure 4.4.12
Worldwide signage and professional display value, by technology
in billions of USD Source: Quelle: iSuppli 2009



of application are already widely deployed in automotive display instrumentation and in early developments of street furniture but, on the whole, the evolution of new displays reflects the importance and growth of data and information services in modern society.

Future displays together with flexible electronics might create an 'intelligent environment' that will help promote broad, intuitive and eco-friendly use of electronics. Technologies for interaction and collaboration (perhaps using networks) will create the fully immersive environments of the future, driving the demand for more and different kinds of displays, such as seamless tiled displays in any desired shape and format for entertainment and advertising. As this requires multidisciplinary R&D, Europe can certainly play a role in these developments.

The market for signage and professional displays today represents more than €10 billion with steady, average annual growth of 15% in revenues, as depicted in Figure 4.4.12.

Figure 4.4.13 Display technologies ranked by CAGR for 2008 – 2013

Source: Fuji Chimera 2008

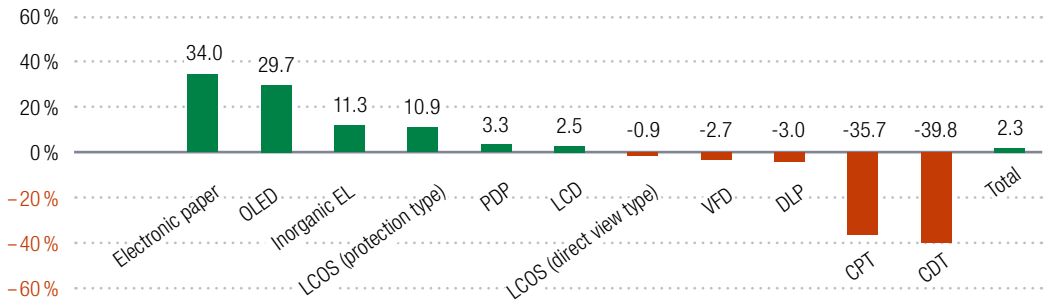

This innovative market is characterised by lower volumes but higher-priced end products, where innovation is driven by image quality, conformability (the ability to be shaped to fit a chosen surface) and energy efficiency, but also by cost-effectiveness. Many technologies will continue to compete with each other, depending on the application. These include LCD, plasma, projection (pulled by the digital cinema transition), LED and OLED (digital billboards) and reflective (electronic paper). High growth rates are expected for reflective and OLED especially, as shown in Figure 4.4.13.

Pico-projectors are arriving on Western markets today as stand-alone devices such as the pocket projector. Either scanning or 2-D imager technologies are being used, combined with solid-state illumination (LED or laser). In future these devices will be embedded in mobile devices such as phones, PDAs or digital cameras. By 2015 pico-projectors are expected to become a huge market of up to 100 million units a year⁷ once limitations on brightness and image quality have been solved, power consumption reduced and satisfactory cost-effectiveness reached. Development of LEDs, laser diodes and CMOS-mounted OLEDs could be the European response to these new markets.

Fig. 4.4.14 Share of luminaire production by European countries is quite fragmented

Figure 4.4.14 The European market for lighting fixtures, 2009 in % of the European market Source: CSIL, Centre for Industrial Studies

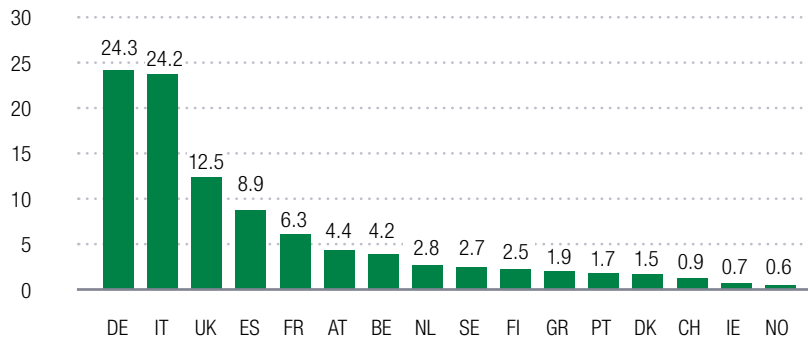
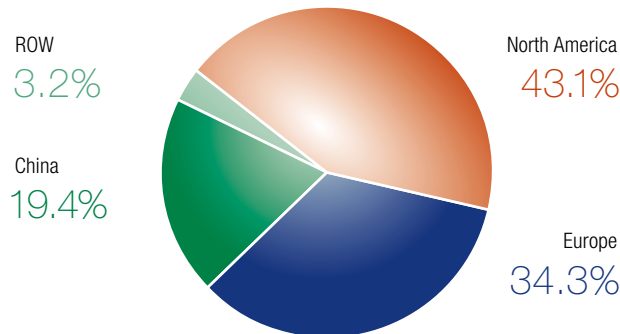

Fig. 4.4.15 Share of LED lighting fixtures revenue by region shows that Europe has a large share of the market

Figure 4.4.15 LED lighting fixture revenue by region 2007 Total 1.51 billion USD Source: Strategies Unlimited, Market Analysis and Forecast, Report OM-45 (January 2009)



7 Insight Media 2009

Europe's position

4.4.2

Lighting

The European lighting industry has established a strong position with a share of about 40% of the world lamp market of €13 billion in 2005. OSRAM and Philips hold equal shares and General Electric (GE) in the U.S. occupies third place.

OSRAM Opto Semiconductors is the world's second largest manufacturer of LEDs with a market share of about 12%. Its main competition comes from Asia and the U.S.. Nichia is the clear market leader with a share of 21%. Other competitors are Cree and Philips LumiLEDs in the U.S. and Seoul Semiconductor in Korea. Many new LED factories are currently under construction in China.

Philips Lighting is the number one player in both professional and consumer luminaires. In this much more fragmented market, with many SMEs, Philips is the only global player, with a 2007 market share of 11% in professional luminaires and 3% in consumer luminaires. The SME-dominated luminaire market is quite scattered across Europe⁸ (Figure 4.4.14 and 4.4.15) with the main players in Italy, Germany, the United Kingdom, Spain and France. In 2007 European companies held a market share of around 35% of the LED lighting fixtures market.

In summary, Europe has an outstanding position in the global lighting market due to its long-standing emphasis on energy-saving solutions. It has gained this number-one position based on incumbent technologies such as fluorescent and high-intensity gas-discharge technology. It was the first large economic region in the world to reach an agreement on banning incandescent lamps. This gives us a head start when taking up the challenge of transitioning to LED and OLED technology and strengthening our position as the global leader in lighting.

Europe has an outstanding position in the global lighting market

Displays

The enormous factories for the mass production of displays and TV sets have left Europe and moved to Asia. In this vein, Asia is spending a considerable amount of private and public money on research and technological development, but with a different emphasis than in Europe. They are continuously striving to reduce the costs of production whilst increasing vertical integration and value-added development within their local countries.⁹ Asian research activities focus on the further development and refinement of technologies for mass production processes.

In Europe, research in advanced displays is driven by radical process and technological innovation and by the creation of novel applications such as e-readers, pico-projectors and immersive displays. As a consequence the prime R&D target is demonstrating the feasibility of new technologies.

As many basic inventions in the area of flat panel displays were made in Europe, Asian manufacturers used to depend heavily on European research and on European suppliers of materials, components, equipment and tools for FPD manufacture. While Europe still holds a great deal of know-how in regard to materials, there is a strong tendency for Asian countries to become independent of foreign suppliers and to increase their production depth and revenues by making key components and equipment in their home region.

Current display trends offer opportunities to regain strength

⁸ CSIL study, "The European Market for Lighting Fixtures", 2007

⁹ Taiwanese Industrial Economics & Knowledge Center, ITIS 2004 and 2008 Taiwan Industrial Outlook

Moreover, this leading position in materials is in question since the EU is investing proportionately less than its main competitors in R&D and lacks world-class production as a source of ideas to drive innovation. While Europe has not capitalised fully on the success of FPDs in the last decade (at least not in production), the current trends towards ambient intelligence and omnipresence of information might offer new opportunities to regain economic clout. Innovative European companies such as Nokia, Thales, Barco and the European car industry are defining requirements from the user end of the value chain.

The display market is currently in considerable turmoil with the rapid development of many innovative technologies and applications born out of the ICT revolution of the past decade. New, flexible display technologies combined with rapid prototyping, low-cost (printed) manufacturing techniques and multi-tiling concepts might offer a rare opportunity to refresh the European industrial and research base in displays.

4.4.3 Technological challenges and research areas

Current and future performance requirements for applications in lighting and displays point to a number of main technological challenges. To meet these challenges several research areas need to be addressed. The following paragraphs describe both the challenges and the research priorities.

Some of these challenges overlap. Both illumination and display technologies need new and better performing materials, new encapsulation methods to achieve flexible shapes and innovative methods to make production cheaper or better tailored to the end user's needs. In this sense, the two sectors could benefit from each other's efforts. Solving the lighting problems could help make Europe's display sector more competitive.

The lighting business is changing dramatically. LEDs and OLEDs are completely different light sources to those in use today and require a different attitude towards lighting. The traditional lamp replacement business will gradually disappear. The market today wants higher quality and more adaptable lighting, while regulations demand more efficient output. This will shift emphasis to the lighting system as a whole. It is not just the light source that determines efficiency of a lighting installation. Lighting control systems



Fig. 4.4.16
Examples of high-
brightness LEDs for
illumination © OSRAM
Opto Semiconductors

will in future be interconnected with building management systems to operate blinds, heating and ventilation as well as the lighting itself in the interest of improving efficiency and reducing carbon dioxide emissions.

SSL offers lighting designers new freedom to create a specific ambience with a large number of individually controllable light sources. The application of LED and OLED lighting systems in general illumination is expected to grow rapidly in coming years. Several technological challenges need to be addressed and significant effort will have to be invested in the corresponding research areas. These are listed separately for LEDs and OLEDs.

Inorganic LED lighting technology

LEDs have improved impressively within the last three years, with a threefold increase in brightness. Today the efficacy of cold white LEDs in production already exceeds than 100 lm/W whilst warm white LEDs emit around 75 lm/W. These white light sources are based on a blue-emitting LED combined with a conversion phosphor. Today the wall-plug efficiency of these white LED components is 35% and is expected to reach more than 55% by 2020. No other light source offers such a high potential for efficiency improvements as SSL. Efficacies exceeding 180 lm/W for cold white LEDs and 150 lm/W for warm white LEDs seem feasible by 2020. High levels of research effort and investment will be needed to reach this ambitious goal.

But when aiming for broad and successful penetration of LEDs into the general lighting market, efficiency is not the only factor that counts. Consumers also want high quality. Visual experience is one of the prime consumer considerations when purchasing lighting systems and true colour rendering will be important. That is why multi-chip modules will be needed. They have two main benefits.

First of all, they are able to generate high light output. The challenge is to densely pack multiple chips on small-scale substrates while allowing the heat to disperse. Light output of up to 5 000 lumens will be required for some applications.

Secondly, multi-chip modules make possible the high colour rendering required for high-quality white light whilst also allowing the end user to adjust the colour. It is possible to add red, orange or yellow emitting LEDs to the colour-converted white-emitting LEDs in order to fill the gaps in the spectrum and so to achieve high colour rendering. Alternatively, the white light can be generated by mixing monochrome red, blue and

High-quality
white LED light
for general
illumination



Fig.4.4.17 LED solutions contribute to impressive modern architecture © Zumtobel

green LEDs. Since this approach does not require any colour conversion, it is inherently more effective. The total output and efficiency of RGB power modules today is limited by the relatively poor efficiency of the green and yellow devices, caused by the 'green gap' between the 'blue' InGaN system and the 'red' InGaAlP system. The performance of high-brightness LEDs in the green-yellow regime must be considerably improved if the ambitious targets for power and efficiency are to be attained.

The generation and the extraction of light need to be raised to more than 90%

The corresponding research priorities are as follows.

- **Increasing LED efficacy to 180 lm/W**

The efficiency of an LED depends on several factors, including the generation of light (internal quantum efficiency) and the extraction of light from the semiconductor (extraction efficiency). Both of these need to be raised to more than 90%. Ohmic losses in turn have to be reduced to a minimum.

LEDs become less efficient at higher currents ('droop') so III-V semiconductor structures need to be optimised for higher current and thus higher operating temperatures and better material quality. Materials that are more reflective and have higher refractive indices are required to increase extraction efficiency. Internal absorption needs to be reduced and surface texturing needs to be optimised.

Improving conversion will require better phosphors. Along with exhibiting high quantum efficiency, they must also minimise scattering without decreasing homogeneity and remain efficient at high operating temperatures (thermal quenching is minimised). New methods for depositing phosphors on the chip need to be explored along with new matrix materials with high thermal conductivity for embedding the phosphor particles.

- **Multi-chip LED modules with high-lumen packages**

To facilitate light mixing, very dense arrays of closely packed LED chips are required. Conventional wire-bond technology and even state-of-the-art soldering techniques will not be suitable. Innovative interconnection technologies, precision assembly and new soldering techniques are needed.

As several thousand lumens are generated it is essential to dissipate heat from the small space occupied by such modules to avoid the efficiency of the LED falling as the temperature rises. Such high-flux applications will need novel interconnect materials with extremely low thermal resistance, low-cost carriers with improved heat spreading properties, such as carbon nanotube composites, and primary optics stable to high-flux light radiation.

- **White LED components with high colour quality**

For high-quality LED solutions the key factor is to increase the colour rendering indices at various colour temperatures while maintaining high efficiency. That can be achieved with new phosphors that have broad emission spectra or emit at various wavelengths with minimised re-absorption. Colour consistency over time has to be guaranteed. Colour conversion requires temperature-stable phosphor solutions while RGB solutions require colour controls (see the discussion below on light engines) which compensate for the divergent ageing properties in LEDs of different colours.

Phosphorless and monolithic white LEDs would offer many advantages. New principles that need to be explored are LEDs based on nanorods, quantum dots or RGB emitting layers in one chip.

Fig. 4.4.18

LED solutions illuminate cultural heritage sites like Helmond Castle
© Philips





Fig.4.4.19 White LEDs illuminate a lecture hall © Spectral Lichttechnik



Fig.4.4.20 LED solutions create a cosy atmosphere © Philips

Besides their superior performance, one of the crucial factors for broad market penetration of LED light solutions is moderate price. The initial costs for LEDs today are usually very high, even though total cost of ownership will be lower due to long service lives and high energy efficiency. The market price for LED lamps tends to be ten times higher than standard lamps with the same performance.

To reduce the initial costs, LEDs must be manufactured on large-area and low-cost substrates in a highly automated production environment. High-throughput fabrication is a prerequisite for cutting costs.

White LEDs of the same type vary in colour and brightness. This is due to the manufacturing processes (metal organic vapour phase epitaxy (MOVPE) and phosphor deposition). LEDs from each colour and brightness group are assigned to a specific bin at the factory. In many applications only selected bins can be used. Solutions for 'smart binning' are urgently needed to make use of all the LEDs produced.

The corresponding research priorities are as follows.

- **Low-cost LED chip manufacturing**

Today, LED chips are usually manufactured on 4-inch substrates. To achieve significant cost reductions in production, LED chips need to be grown on larger size substrates of from 8 inch to even 12 inch and on other types of substrates such as low-cost silicon or glass. The technological challenge is to achieve high-quality epitaxial semiconductor layers grown by MOVPE on these substrates. New, easily controllable low-cost deposition methods would bring the cost breakthrough needed in the long run.

- **Solutions for LED binning**

To use the full production range of LEDs new and simple methods for binning (colour mixing or blending, better control of the production processes) need to be explored to increase the yields in production and so lower the cost.

Due to the long lifetime of LEDs, there will ultimately no longer be a market for replacement lamps. As a consequence the focus of the lighting market will shift towards initial LED 'light engines' for luminaires, LED-based luminaires and systems. The system aspect will become much more important in future, as it is not only the light source proper that determines the performance of the lighting installation.

Low-cost LED component manufacturing

LED light engines and luminaires with high functionality



Fig. 4.4.21 A street lit by high-pressure sodium lamps (left) after conversion to LED lighting (right) © OSRAM Opto Semiconductors

To create a highly efficient light source we need to focus on the whole system, not just on the LED component. This includes thermal management, electronics and optics.

In operation, the LED efficiency will drop significantly as the junction temperature rises. In general, the efficiency falls by 20% but in red LEDs it can drop by almost 50%. New concepts for sophisticated thermal management are the key. The LED itself, the light engine and luminaire must all deal effectively with the heat generated by the LED.

A particularly attractive feature of LED light sources is the ability to regulate the colour mix by tuning the individual RGB drive currents. This offers completely new possibilities to control colour according to personal mood. It will become possible to create adaptable and even dynamic scenes for indoor lighting in bars, restaurants and homes and for outdoor architectural lighting. Due to their tiny size and unique form factor, LEDs offer great freedom to make design a discriminator in the market place.

Electronic power supplies, though bulky, do give basic control of intensity and colour and are available in many versions. The challenge, however, is to optimise their functionality, reliability and efficiency as well as cost and, in particular, to reduce their size. The most important problem, though, is their lifetime. LEDs can easily last for up to 50 000 or even 100 000 hours, far longer than the 20 000 hours expected from conventional power supplies. This is now the limiting factor for the lifetime of LED light engines or luminaries.

Light from an LED can be used more efficiently than from conventional lamps as it emerges in only one direction. The development of integrated optical elements will play an essential role in exploiting this advantage. One application where this directionality is extremely valuable is street lighting. The LED light can be focused on the street directly where it is needed, so reducing light pollution. Even today an LED street luminaire consumes far less power than a luminaire equipped with highly efficient, high-pressure sodium lamps (Figure 4.4.21).

Further challenges for the optics are homogeneous light mixing (to blend the colours of the different LEDs), low losses, advanced beam shaping and glare reduction. For other emerging applications such as automotive headlamps, backlighting of large LCD panels or LED-based projectors, the combination of high flux and directional emission is key. Applications in which the light is imaged by an optical system demand much better directionality than the typical Lambertian emission profile.

The corresponding research priorities are as follows.

- **Advanced thermal management**

Novel concepts for thermal management are required, involving the use of new materials such as polymers, glasses, ceramics or composite materials which provide high

Better electronics, thermal management and optics are needed

thermal conductivity at moderate costs. In addition to passive cooling, special emphasis must be given to new active cooling systems as this is the only way to keep the light engines or luminaires small, even at high light outputs. They will need to be quiet and consume little power.

- **Reliable driver electronics**

Electronics are needed to exploit the unique features of LEDs such as colour steering and dimming. Low-performance electronics may ruin the positive image of LEDs and so driver electronics should be highly reliable but also low-cost and quiet. Innovative driver architectures and circuit solutions that meet the requirements for longer lifetimes will enable successful introduction of new SSL-based lighting products.

The electronic driver has to guarantee that colour coordinates remain stable over time for LED light engines and luminaires. The emission colour must be controlled by sensors and steered by smart microcontrollers. Integrated intelligent electronics can control colour and also compensate for ageing of individual LEDs in the module itself. The combination of the photonics III-V world with the silicon world is highly attractive in that respect.

LEDs can also be dimmed. Special attention needs to be paid to the colour temperature adaptation during dimming since LEDs, as opposed to incandescent lamps, do not change their correlated colour temperature (CCT) with brightness. Acceptance studies are needed to determine users' requirements.

- **Low-loss optics and advanced beam shaping**

The optics will have to produce various beam shapes and put the light where it is needed, thus reducing waste and light pollution.

We need to explore optically optimised solutions which cut losses to less than 10% and can be fabricated by highly automated, standard methods such as injection moulding. Special nano-coatings may enhance the performance of these optical elements.

Colour homogenisation is extremely important if LED luminaires are to be accepted, so this is one of the major requirements of the optics. Colour fringes must be avoided. Sophisticated lenses, reflectors or a combination of the two have to be explored for the integrated primary optics of the LED light engine as well as for secondary optics of the luminaire. New ways are needed to mix light homogeneously while conserving the etendue.

- **Standardised LED light engines**

A standardised LED light engine with a defined thermal and optical interface that could be used in various luminaires would stimulate the LED luminaire business and is essential to reducing cost. This will help European luminaire manufacturers adopt LED technology.

Lighting accounts for 25% of the total energy consumed in commercial buildings and 39% of that in offices. The overall efficiency of lighting, especially in buildings, can be further increased by combining efficient SSL solutions with intelligent light management systems in which lighting is controlled according to the presence of people in the room or the ambient daylight. Some 20 to 50% of the energy used in buildings could be saved in this way. While individual systems and some sensors already exist, standardised communication protocols are lacking as are intelligent light control algorithms, integrated controllers and intuitive interfaces.

Intelligent light
management
systems

The corresponding research priorities are as follows.

- **Sensors**

Appropriate sensors and sensor networks must be developed before LED modules and luminaires can be incorporated into energy-efficient lighting systems. Sensors and algorithms should be smart and intuitive, creating a good user experience. Low-energy and autonomous wireless sensors could have a part to play.

- **Standardised protocols**

Integrated controllers and standardised communication protocols guarantee the interoperability of components from different suppliers.

- **User acceptance studies**

LEDs offer new opportunities, through controlled colour changing, to imitate the natural rhythms of night and day. Acceptance studies are needed to explore the biological impact and opportunities offered by these effects.

OLEDs open the way to large-area lighting built in to walls and ceilings

OLED lighting technology

OLEDs also have a strong potential for lighting. They promise novel lighting systems with functionalities that go beyond what is achievable with LEDs. Their broad emission spectrum makes OLEDs a very pleasant source of light. Because they are flat, OLEDs offer new options for design and open the way for large-surface-area lighting built in to walls and ceilings. And once OLEDs can be manufactured on plastic substrates as well as glass, conformable and flexible light sources will also come within reach. Last but not least, there are tremendous opportunities for using transparent OLEDs in windows and facades. These will allow each room to have a single source of light, natural light during the day and electrical light after sunset.

Much research on OLEDs has been performed around the world. One main finding is that the efficiency, lifetime, brightness and size of the active areas are hard to reconcile with each other. It has been possible to achieve record values for efficiency, brightness and lifetime, and thus to demonstrate the potential offered by OLED technology, but not all at the same time. The challenge now is to combine all these properties into high-quality devices with high flux, high efficiency and lifetimes exceeding 5 000 hours and all at moderate cost. Only then will OLED lighting be ready for the market. Thus special attention must be paid to the early standardisation of OLED metrics, devices and electronic drivers so that interoperability issues can be tackled in an early market phase.

High quality white OLED light for general lighting

To enter the market for general illumination, the efficacy and lifetime of OLED lighting must be increased to the level of inorganic LEDs. At the same time, the brightness should match that of fluorescent lighting. The combination of these properties is a very daunting challenge to materials technology.

The biggest challenge is to develop a highly efficient blue emitter with a long lifetime. Although some phosphorescent blue emitters are available, these either have short lifetimes or the wrong colour coordinates for building reliable white light products. Some others require licences from non-European companies. And sourcing from a single material manufacturer makes production very unpredictable and risky.

Another materials challenge is to make OLEDs with a long lifetime and high brightness. This requires charge transport and injection materials especially suited for high efficiency and long lifetime at higher brightness levels.

Another challenge specific to OLEDs lies with their external quantum efficiency. Without any light-out coupling measures, 80% of generated light will not escape from the

front surface of the device, as required, but will be lost through waveguiding to the side. Efficient light-out coupling methods are needed, and this is the fastest way to improve OLED efficiency.

Research priorities are as follows.

- **Highly efficient OLED devices**

The highest priority should be given to maximising the external quantum efficiency at the long lifetime of OLEDs, with targets beyond 100 lm/W and 20 000 hours of lifetime (defined as T_{70}) at brightness levels in the order of 5 000 cd/m². With OLED tiles made to this specification, smaller and cheaper modules can be built for uses such as office illumination. This requires tremendous work in OLED stack development and integral solutions for luminaires such as OLED tiling concepts.

- **Highly efficient OLED materials**

To reach these levels of performance, projects are needed to target breakthrough materials such as highly efficient emitters (especially deep blue), charge transport and injection materials, and materials specially suited for processing at high speed or optimised for high-temperature vapour phase deposition. This will shorten manufacturing throughput times. Materials with higher electrical conductivity are also desirable since they can be used in thicker layers to make more robust designs.

Secondly, it would be interesting to speed up development by computer simulation of the various materials and stack options. Simulation tools with good predictive power for optical and electrical OLED stacks will help reduce the workload during stack development. Novel methods for predictive quantitative analysis of material properties are also needed and will support the screening of novel OLED materials.

Special attention should be given to cost-effective alternatives to (printable) indium tin oxides (ITO), to transparent electrode materials and to low-cost bendable substrates for OLED lighting. These are needed if OLEDs are to be used in flexible and transparent light sources.

- **Efficient light-out coupling**

Efficient and cost-effective light-out coupling for flat light sources could be tackled by exploring 2-D and 3-D nano-structured materials, or by including suitable plasmonic structures within the OLED structure. Theoretical studies show that this approach gives a large boost in external quantum efficiency but it needs to be evaluated in practice.

OLED lighting products are still so expensive that massive action is required to bring the investment cost per lumen down to the level of today's LEDs, let alone the conventional lighting technologies used at present. Several types of action are needed. Priority should be given to all research and development that brings the OLED deposition costs below €100/m² in a mass-production environment.

The corresponding research priorities are as follows.

- **Cost-effective OLED manufacturing methods**

More cost-effective methods of production could be based on low-cost gas-phase deposition with high material utilisation, manufacturing by lamination or printing of dif-



Fig. 4.4.22
The latest transparent
OLED light source
(17 x 17 cm) © OSRAM
Opto Semiconductors

Low-cost
OLED
manufacturing



Fig 4.4.23 Visual inspection during OLED pilot production in Aachen, Germany © Philips

ferent layers, and ultimately by roll-to-roll (R2R) manufacturing. The thickness of the layers is crucial for the final efficacy of OLED devices, so special attention should be paid to aspects of R2R manufacturing, as well as know-how and development in processes for large-scale industrialised production, such as modelling and process control systems for fabrication.

- **High-performance OLED materials suited for high-speed processing**

This will require the development of novel, high-performance materials suitable for high-speed vapour phase processing, as well as similar materials suitable for R2R processing. Materials need to be stable and optimised for the high temperatures used during vapour phase deposition. These novel materials have the same requirements for lighting and for displays.

- **OLED reliability and lifetime**

In operation OLEDs tend to fail by short circuiting. Eliminating this failure mode will require further research and exploration on how

devices perform in practice. This could be achieved with novel materials exhibiting higher conductivity, so that thicker layers can be used during processing. Another way to improve reliability is through more robust designs such as stacking or special fault-tolerant layouts. Both methods need to be studied in close relation to novel production methods.

We also need to establish general engineering reliability practices for manufacturing. For example, dependable test procedures are needed to predict the behaviour of OLEDs during their life as well as studies of the root causes of failure in OLED materials and devices.

Conformable, flexible and transparent OLEDs

For designers, the ultimate functionalities unique to OLED lighting are transparency and flexibility. This requires transparent electrodes with high conductivity, as well as suitable substrates and barrier layers to protect the sensitive OLED materials from degradation and scratches.

To achieve this, the following research areas need to be addressed.

- **Flexible substrates and transparent barrier materials**

It is necessary to examine substrates that meet the processing and product requirements for the changes needed in the design of the OLED stack and choice of materials.

- **Encapsulation methods**

Reliable encapsulation methods for both rigid and flexible substrates will give future applications a shelf life of at least 10-15 years.

Display technology

Although Europe has ceded the flat-panel display market to Asia, there are still plenty of growth opportunities for Europe in areas related to displays. Many of these opportunities are in more advanced sectors such as high information density displays and 3-D, immersive or head-up displays. As these technologies mature, they are gradually moving from military applications into the consumer and automotive markets.

The number of applications for low-information displays is also growing and some of these could be supplied in very large volumes. One example is displays integrated into

food packaging which change colour when the 'use by' date has passed or when the product has otherwise deteriorated.

Europe should also be able to defend its leading position in the value addition chain especially in supplying materials or devices (LEDs for backlighting) and assembling special, high-value products. Constant innovation driven either by research on materials and equipment, or by a dedicated focus on the needs of customers and the market, is required to develop a market for speciality display products.

In modern societies, displays will play important roles in communication and decision making involving people in different physical locations. More advanced, high-quality, high-resolution displays will bring closer the advent of fully immersive environments. The challenge lies in creating displays that are truly immersive or 'photo-realistic' to give individuals or multiple users the illusion of true, real-time interaction. It will also give rise to much more intuitive collaboration techniques, suitable for many other domains such as remote surgery.

The first head-up displays are already being integrated into high-end cars. Although the time to widespread market acceptance is thought to be quite long in this case, the aging of the population could quickly bring about a need for information to be easily accessible while driving a car safely.

Research priorities are as follows.

- **3-D stereo visioning**

Stereo vision requires the development of 3-D displays (including auto-stereoscopic viewing and its related computational rendering) or novel designs for head-up or head-mounted displays.

- **Full colour and size-adaptable displays**

Advanced information displays need to be adapted for quality or size. At present the colour gamut and refresh rate are barely capable of meeting the visual quality factors the eye can detect. OLED displays have an advantage over LCD displays in that respect. A constant focus on innovation could give European companies a firm foothold in the value addition chain for OLED displays.

European players at the supply end of the value chain can contribute here as long as good relationships with Asian panel makers can be created. At the other end of the chain, European speciality and niche display makers (avionic, automotive, professional and industrial) may profit from state-of-the-art OLED technology, materials and lighting infrastructure available in Europe as long as they can maintain good access to OLED backplanes from Asia.

- **Novel liquid-crystal materials**

New classes of liquid-crystal materials will be required to achieve the colour fidelity and speed required. Within Europe we have a very rich history of understanding the system-level challenges that such developments drive, as well as the measurement and understanding of the human factors involved. These areas all offer opportunities for European innovation to create new business developments and value within Europe and worldwide.

- **Data management solutions**

Very fast and very high-resolution displays will create opportunities not only in content provision but also in data management,

Advanced information displays

A constant focus on innovation could give European companies a firm foothold in the value addition chain

Fig. 4.4.24 Electrowetting displays make new applications possible, like this socket power meter © Liquavista & Daan Pothoven





Fig. 4.4.25 Pico-projectors are energy-efficient, small and lightweight, and provide new ways of making large-area displays for mobile applications © Fraunhofer IPMS

hardware distribution and communications. A modern display has over a million pixels. Moving towards tens or hundreds millions of pixels will create data management challenges at the systems level that will transform requirements for the backplane and system design.

Low-cost flexible displays

A substantial market is also expected for low-cost flexible displays with medium to low information density. Some of these challenges are already being addressed and the European retail sector has engaged technology providers in field trials of such systems for point-of-sale labelling on edges of shelves and counter tops. However, much still needs to be done before these types of display can be further commercialised.

The challenge for a fully reflective, full-colour display is immense. There is no such display available today that meets the needs of the wider market, even though European initiatives in chiral nematic liquid crystal displays have been subjected to trials. A market already exists for shelf-edge labelling and for information displays in street furniture and retail premises. Extending this to a wider deployment in packaging and in very large area displays for outdoor display advertising is a further challenge in a field where Europe has technological leadership and a powerful business advantage.

This work will support complementary developments in distributed electronics and functional manufacturing platforms based upon printing.

The following research challenges should be addressed to make this happen:

- displays with better image quality (for use in direct sunlight), higher reflectivity or higher contrast ratio;
- full colour capabilities (for advertisements);
- increased operating speed for better real-time interaction;
- minimised energy consumption for stand-alone or non-serviced applications;

- improved reliability and lifetime for rugged products that are also suitable for outdoor applications;
- development of novel liquid crystal technologies such as smectic-A, ferro-electric LC and chiral nematic LC;
- new printable transparent conductors and functional electronic inks as well as substrates and printing materials. Innovations in such technologies will also stimulate the design and graphic industries, as has already happened in some sectors of the architectural and advertising design communities.

A second-order research area is to tackle the problem of screens of different sizes within interactive environments. Research on solutions for seamless tiling and smart interconnection of multiple high-quality displays would be welcome.

A common technical challenge for all segments of the display market is the further improvement of energy efficiency. Much work has already been done on the stand-by energy consumption of displays. The average stand-by power has decreased from 3 watts in 1999 to less than 0.5 watt in 2007. Now the technological challenge is to limit energy consumption during operational use. Examples include e-paper and electrowetting displays, or projection systems based on lasers or LEDs. Special attention should be given to the environmental issues for mobile displays as more and more devices with larger screens appear on the market.

Energy-efficient (mobile) displays



Fig. 4.4.26 LED-based mobile pico-projectors © Sypro Optics

Research priorities are as follows.

- Development of novel display technologies with minimal energy consumption, such as self-emissive OLED displays or reflective displays that do not need a backlight. This enables stand-alone operation for a very long time on batteries or renewable energy sources such as solar power.
- Development of colour versions of displays fore-readers, able to play content at video rate quality.
- In order to make laser-based projection a commercially viable display, there is great need for a green laser. This could be based on direct green emission lasers or on efficient frequency conversion of IR or Blue/UV type lasers.
- Highly efficient LEDs for mobile projection. ●○○



Fig. 4.4.27 Urban illumination with LED technology in Millennium Park, Chicago © Hedrich Blessing

Market overview	<p>Lighting</p> <ul style="list-style-type: none"> • €58 billion global market (2007). • Global lighting needs will increase by a factor of 1.4 from 2005 to 2020 and by a factor of 2.9 by 2050. • High-brightness LED market is expected to grow to \$14.9 billion in 2013. • Luminaire market was €36 billion in 2007 and will exceed €56 billion in 2015. • 2012: LED-based luminaire market estimated to be \$5.3 billion. • OLED lighting market predicted to hit the \$5 billion mark between 2014 and 2018. <p>Displays</p> <ul style="list-style-type: none"> • FPD market around €100 billion. • OLED display market less than €5 billion in 2015. • Fast-growing market in reflective and OLED displays and pico-projectors. 		
Europe's position	<p>Lighting</p> <ul style="list-style-type: none"> • People employed in Europe: over 150 000 • Turnover of the European lighting industry: €20 billion • European world market share: 40% in lamps • Market share of European companies: 35% of global fixture market • OSRAM Opto Semiconductors is the world's second largest LED manufacturer with a market share of 12% • Philips Lighting is the number one company in luminaires and the only global player with a market share of 11% in the professional market and of 3% in consumer luminaires <p>Displays</p> <ul style="list-style-type: none"> • FPD market completely dominated by the Asian-Pacific region • EU strong in specialised, high-value display segments (OLED visors, professional displays, LEDs for backlighting) as well as LC materials and production equipment • Smaller portion of TV set making within Eastern Europe. 		
Focus areas:	LED	OLED	Displays
Techno-logical challenges	<ul style="list-style-type: none"> • High-quality white light for general illumination • Low-cost LED manufacturing • LED light engines and luminaires with high functionality 	<ul style="list-style-type: none"> • High-quality white light for general illumination • Low-cost OLED manufacturing • Conformable, flexible and transparent OLEDs 	<ul style="list-style-type: none"> • Advanced information displays • Low-cost, flexible displays • Energy-efficient (mobile) displays
Research areas	<ul style="list-style-type: none"> • Inorganic LEDs aiming for >180 lm/W efficacy • LED light sources with high light quality and high lumen package • Low-cost LED chip and package manufacturing • LED luminaires • Intelligent light management 	<ul style="list-style-type: none"> • Efficient OLED devices, materials and efficient light out-coupling • Low-cost manufacturing solutions • OLED reliability and lifetime • Substrates, barriers and encapsulation for flexible and transparent devices 	<ul style="list-style-type: none"> • 3-D displays, novel LC materials with full colour gamut • Colour reflective displays • Sizeable and tileable displays • Efficient green lasers

4.5

Photonics for safety and security

4.5.1

Market overview, main drivers and challenges

Continuous advances in wealth and welfare, the result of more than sixty years of peace in Europe, has brought with them a demand for safety. Due to the huge improvement in European standards of living, we are less willing to accept risk as a natural fact of life. Even in natural disasters, which in the past were considered to be acts of God, we tend to look for someone to hold responsible, perhaps due to 'negligence'.

Europe's open, democratic, welfare societies, combined with globalisation and the end of the cold war, expose us to several security risks such as organised crime, terrorism and trafficking in drugs, people and hazardous materials. The security challenge has been taken up at European level and is now a specific priority in the EU's Seventh Framework Programme.

We distinguish between 'safety', which protects people against accidental harm, and 'security', which protects people against intentional harm from others.

The challenge of security has been taken up at European level

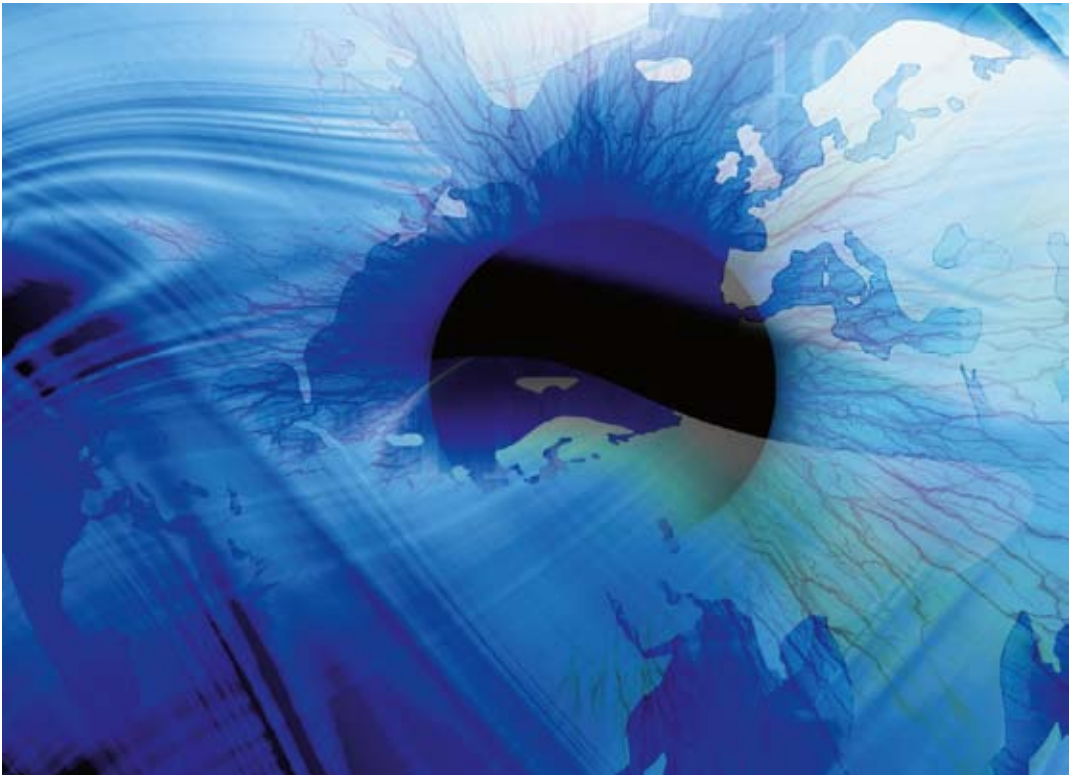

Fig. 4.5.1 The importance of safety and security in Europe © Fotolia

There is no such thing as ‘zero risk’ in safety and in security, and no solution can be 100% safe or secure. The best results are obtained with:

- organisations or infrastructure designed to minimise any risk, such as using less-flammable materials in buildings or trans-border political cooperation to reduce illegal border crossings;
- improved situational awareness to an incident from becoming a disaster and triggering a crisis;
- well-prepared and equipped first responders driven by an efficient crisis management organisation.

These measures must not infringe on citizens’ rights and should intrude as little as possible.

Photonics can play a prominent role, especially in situational awareness, for three reasons.

- The use of light is ideal for remote, contactless detection and measurement that imposes no burden or load on the object being surveyed.
- The short wavelength of light can be used to sense the detailed geometry of objects for more reliable recognition and fewer false alarms.
- Molecular or atomic interactions with light can provide spectral signatures of substances, allowing a sharp distinction between acceptable and prohibited goods. New developments in photonic sources, such as quantum cascade lasers and novel terahertz sources, allow unprecedented, highly selective detection of organic and non-organic substances.

Imaging, such as that used in video surveillance, will continue to play a major role as it is a natural way to convey complex information to the brain. Photonics can enrich images with other data such as polarisation, distances and multispectral information. These can improve situational awareness either visually to a human operator or by downstream computing. Low-cost, high-performance optical surveillance sensors will emerge from novel techniques using structured optical materials for all-optical processing or pre-processing and from fundamentally different image processing methods.

Until now photonics technology for safety and security has been based on military research that started just after the Second World War. As a result the defence photonics sector in Europe has turnover of €3 billion a year compared to €20 billion in global turnover, which is dominated by the United States. Most of these industries are now adapting their ‘situational awareness’ and photonics knowledge to the civilian world of safety and security.

Over the past few years the photonics-driven security market (video surveillance, biometrics and so on) has experienced double-digit growth and will soon exceed the stagnating military market. Companies not working in the defence sector have also had an opportunity to take a big share of this new market.

Although commercial rules in the safety and security market differ from those in the defence market, national governments and the EU have an important role to play beyond supporting research. As governments are ultimately in charge of safety and security, the market is split into three main parts:

- Direct purchase by governments to improve their ‘functions as sovereign states’, such as border control and surveillance, policing and surveillance in urban areas.
- Improving safety and security through regulation. Competitive pressure does not normally encourage private companies to improve their safety and security. The question

Photonics can enrich images with information beyond the range of the human senses

The photonics-driven security market has experienced double-digit growth

is, “as an individual, how do I benefit from improving local safety and security?” The role of governments and the EU is to define by way of regulation the equipment that private enterprises have to procure (such as baggage screening equipment at airports) without jeopardising healthy competition. Such processes are rather long and drawn-out and need mature technologies, this being due to the involvement of governments or international organisations.

- Open market: such a situation is reached when safety and security equipment brings immediate advantages to the purchaser (video surveillance against burglary is one example). Even then, government may have a role in ensuring that the equipment does not infringe on citizens' rights.

Safety and security equipment often uses leading-edge technology that governments may wish to restrict for reasons of national security or to protect commercial interests. Such situations may lead to distorted competition in the market. Photonics has many examples of where such 'sovereignty technologies' are needed to design and build leading-edge competitive equipment.

4.5.2 Europe's position

The total world market for safety and security equipment using photonic sensing is €22 billion. The safety market accounts for €7 billion, including €2 billion for air pollution detection and €5 billion for the automotive sector.

The €15 billion security market, with an expected growth of 15% CAGR, is a very attractive market which has grown to 75% of the size of the slow-growing defence market for photonic sensing and in a few years will surpass the defence market. In such an environment European industry has chosen well, as it takes 30% of the whole market but only 15% of the defence sector. For the two larger segments Europe holds a revenue share which is higher than the 30% mean value:

- Europe's share of the biometric market is 45% of €5 billion¹;
- Europe's share of the video surveillance camera market is 40% of €1.7 billion.

This position has been achieved mainly by large industrial groups coming from the defence sector which are accustomed to large, capital-intensive technical and commercial developments. They include, among others, EADS, Finmeccanica, Sagem, Siemens, Smith Detection and Thales.

These companies compete mainly with large groups from North America. Their relative success compared to the defence sector is due to Europe's good technical skills, both in industry and research, and fewer commercial barriers. These large groups, which earn the bulk of European revenues, sell systems, equipment and services. They purchase many of their parts from a large number of smaller companies and buy their photonics components on the world market to obtain the best prices. These components often come from the United States and Asia. There are no restrictions on supply at present, but as certain high-performance components gain in strategic value they could become subject to export restrictions as has already happened in the civil aeronautics sector. For that reason it is vital that Europe maintains its technological capabilities in photonic sensors through leading-edge research.

Europe should maintain its technological capabilities in photonic sensors through leading-edge research

¹ Frost and Sullivan Reports, 2007-2008

There is a large and growing market in safety and security.

- The security segment for equipment using photonic sensing amounts to €15 billion, with expected growth of 15% CAGR.
- The biometrics market amounts to €5 billion, with expected growth of 18% CAGR.
- The video surveillance market amounts to €5 billion, with expected growth of 12% CAGR (surveillance cameras represent 40% of this segment)².

Europe already has a strong position in safety and security.

- Europe has a 30% share of the worldwide safety and security market.
- Europe's share of the biometric market is even higher, at 45%.
- Photonic sensors are key components that strongly influence the competitiveness of the equipment.
- Future high-performance components might become subject to export restriction, leading to market manipulation.
- Europe has to master the optical sensor 'sovereignty technologies' to retain its market share and enhance competitiveness.

Europe has a strong position in safety and security

Current markets and trends

In this section we give more information on some important, specific segments with market figures, trends and technological needs.

4.5.3

Video surveillance

The video surveillance market, by definition, relies on photonic sensors. The market is split into two parts:

- Equipment (see below for the market figures).
- System installation and support. This is estimated to be 1.5 times the size of the equipment market, mainly due to the engineering works still needed for power and video cables even though video on IP (video over the internet) is growing strongly.

4.5.2 Video surveillance enhances public safety
© Sagem

The future market needs are threefold:

- Image quality and operation over a wide range of lighting conditions is a driver for cameras, where Europe has a very large share. Today's cameras need supplementary illumination at night and when light levels are low, so new methods in image processing and compression and optical design are needed. Future practice will supersede traditional rules and will have to integrate image processing capabilities into the optical design process from the very beginning.
- Embedded intelligence and novel procedures for wavefront processing and optical preprocessing will reduce workload and improve operator efficiency.
- Autonomous operation (self-assembling, wireless systems without human intervention) will make systems cheaper and easier to install as they are self-contained and consume little energy.

The market for video surveillance equipment consists of cameras, storage, encoders, video servers, monitors and software.

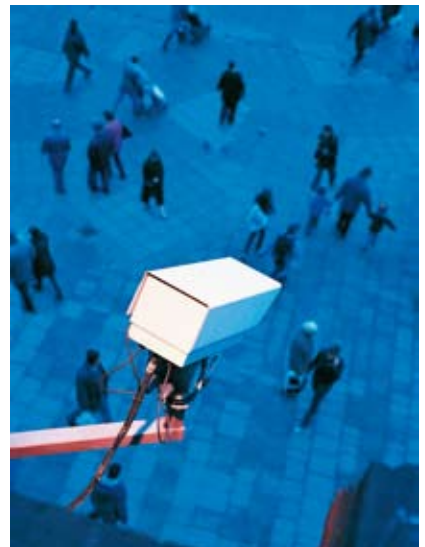

² Frost and Sullivan Reports, 2007-2008

Growth in the government and public surveillance market is less likely to have been affected by the global recession.

Innovative image sensors will have an impact on the video surveillance market

- **Cameras** (both analogue and network): There is a mature market, especially in parts of North America and Europe, equivalent to 40% of the total video surveillance market. Europe has a strong position, providing 40% of the camera market.
- **Storage** (network or digital video recorders): Around 37% of the total video surveillance market. North America is one of the best-developed regions, with 10% CAGR expected for 2009-14. Europe is growing more slowly, with 4% CAGR expected to 2014. North Asia (outside Japan) has the highest growth rate of 15% to 2014. However, regions with the highest growth may be more vulnerable to the economic downturn.
- **Monitors**: Aggregate market revenues in North America are expected to reach €4.3 billion by 2014.
- **Encoders**: The global market is up to €2.4 billion with 21.2% CAGR (the forecast for Europe is unknown).
- **Software**: This includes video management and video content analytics, augmented reality, and real-time modelling of scenes captured by video surveillance systems. It is the fastest growing segment, at 26.5%, due largely to the North American market. It is still in the early stages of introduction in North Asia. (European market is unknown).³

Figure 4.5.3 Video surveillance market (2009 – 2014)

in billions of euros Source: Frost & Sullivan Reports (2007–2008)

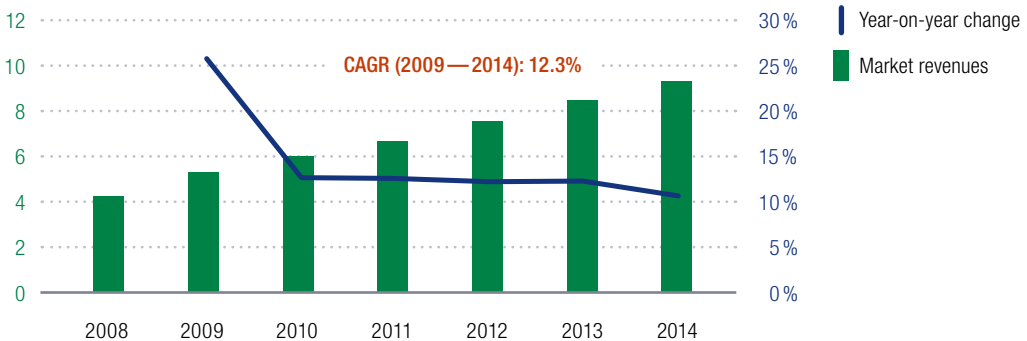

Figure 4.5.3 shows the importance of video surveillance. Account must be taken of the entire video surveillance market as innovation in photonic image sensors will affect the entire chain. In future the encoders will be in the image sensor and part of the software.

Border surveillance and control

For several years border surveillance has been an attractive market for photonic sensors. Although photonics sensors are not the only ones used in surveillance systems, they are essential since visual images are needed by the operator to confirm any intrusion and decide on the course of action.

³ Frost and Sullivan Reports, 2007-2008

At present the cost of border surveillance is driven by salaries and every country is aiming to introduce more automation. Watching a display screen for any length of time is fatiguing, so automated detection will free operators for the more productive tasks of interpretation and decision-making. Most of the technical improvement in video surveillance would also benefit border surveillance even though border surveillance has its own unique requirements.

Photonics sensors are essential for border surveillance

Many countries, including those in Europe, need to prevent illegal emigration, immigration and smuggling, and the trafficking in people and goods which feeds international crime and terrorism. The first customers are the developed countries because they can afford to buy such equipment and are attractive destinations for illegal immigration and all kinds of trafficking. The example of the border between the United States and Mexico is well known. The European Union is also developing surveillance and control at its external border, as defined by the Schengen area. The first step is to introduce biometric passports and visas to curb illegal immigration by those who enter legally but do not leave. This is currently the highest contributor. Borders in low-population areas can be protected by video equipment and other sensors. One example is the southern stretch of the border between Finland and Russia.



Fig. 4.5.4 Finger and iris biometrics rely on photonic sensors © Sagem

The cost of surveillance equipment for land borders is roughly €115 000 per kilometre, of which 10% is for photonics-based equipment, mainly cameras. The potential market is therefore very large but experience shows that only rich countries (the Western world and oil-producing countries) are buying the large systems provided by the large industrial groups. Such contracts can be worth as much as a few billion euros each.

At the moment the photonics equipment itself is not the selling point for these contracts as the engineering work needed to put the system together is the most expensive part. Technical progress in wireless video sensor networks, for both communication and power, will dramatically reduce the cost of the entire system by obviating the need for expensive wired connections. This is a trend shared with video surveillance.

Figure 4.5.5 Global biometrics market (2009 – 2014)

in billions of euros Source: World AFIS Market 2008 (Frost & Sullivan), Identification Market 2007 (Pira), Sagem Sécurité estimation 2008

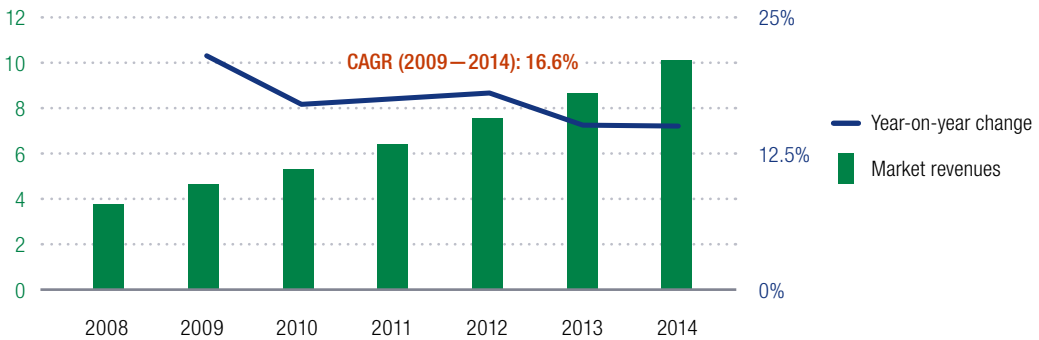

Biometrics and related applications

Photonic sensors are key to biometrics as they capture the basic information to be processed. Huge progress has been made in algorithms related to various biometric techniques such as fingerprints, iris and retina scans, facial recognition, hand geometry analysis and vascular pattern analysis. At the same time, work needs to continue on photonic sensors for information capture that are contactless, quick, insensitive to lighting conditions and require little or no action on the part of the person being screened. Equipment is also becoming smaller and costs are falling.

Applications for photonic-based biometric systems include:

- access control and attendance monitoring for safety and security systems and information systems associated with emergency assistance and rescue in case of fire or accident;
- identification systems enabling rapid response in case of medical emergency;
- biometric signatures for cashless payment.

Fig. 4.5.6 X-ray baggage checks are used to detect prohibited items © Sagem



Detection of dangerous or prohibited goods

Detection of hidden dangerous or prohibited goods applies to:

- screening air cargo co-loaded on scheduled passenger flights;
- screening cabin baggage at airports;
- screening at secure facilities;
- screening postal items;
- screening freight in supply chains;
- bomb searches by emergency services.

This can be achieved through two main methods:

- X-ray detection can penetrate most coverings. The main parameters detected are shape, mass and density. Since most prohibited substances have a narrow range of densities there is a good chance of detecting suspect items.
- The analysis of the spectral signature of the molecule (by ultraviolet to infrared spectrometry) is much more accurate and reliable but needs an air sample. The main problem is to obtain the sample easily and efficiently in any environment

Figure 4.5.7 U.S. market for X-ray detection equipment

in millions of USD Source: Homeland Security Research Corporation forecasts

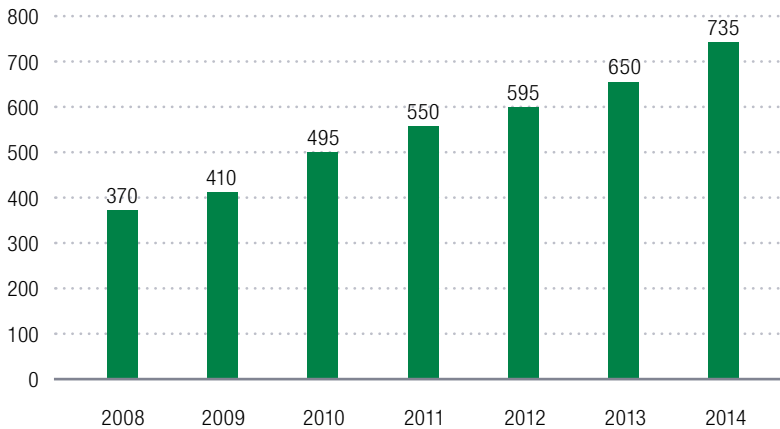

and to analyse it quickly. Molecules of concern are likely to be present only at very low levels.

Currently the bulk of the market is made up of X-ray equipment (Figure 4.5.7), complemented by equipment for molecular signatures. Millimetre (up to 100 GHz) and sub-millimetre (up to 1 THz) wave imaging (also known as terahertz imaging) is a growing market, especially for passenger screening, as the radiation is safer than X-rays yet can pass through non-metallic coverings and perform some signature analysis. Although market share is small, a growth rate of 29% is predicted to 2014.

There are no consolidated figures for the global market for security and screening but it has been estimated at 2.5 times the size of the U.S. market, namely €900 million in 2008, and is expected to rise to €1800 million in 2014, at more than 12% CAGR.

Photonic sensors are key components in present-day X-ray equipment and future terahertz equipment. They are also used in some molecular signature analysis devices from ultraviolet to infrared. The trend there is the same as in other domains:

- more sensitivity so emitted power can be minimised;
- higher resolution images (more pixels);
- 'smart pixel' technology (where pixels perform additional functions) for sophisticated measurement methods such as time resolution, spectral sensitivity and so on.

Photonic sensors are key components of present-day X-ray equipment

As regards active methods (X-ray, ultraviolet to infrared spectrometry and terahertz) the first challenge is reliable, compact and cheap sources. All of these components are tailored to the application.

Detection of pollution

When analysing pollutants, the main methods are:

- chemical analysis;
- chromatography;
- spectrometry;
- remote sensing methods.

Photonics is involved directly in spectrometry and remote sensing methods

Photonics is involved directly in spectrometry and remote sensing methods but also indirectly in chemical analysis and chromatography to read the results.

The market for pollution detection is divided into four parts:

- air pollution;
- water pollution;
- soil pollution;
- chemical warfare agents.

Figures are available in the literature only for air pollution, which is the main market sector (Figure 4.5.8). The world market for air pollution detection will reach about \$25 billion in 2012, according to BCC Research, and this includes both photonic and non-photonic equipment.

Figure 4.5.8 World market for detection, control and prevention of air pollution

in billions of USD Source: BCC Research

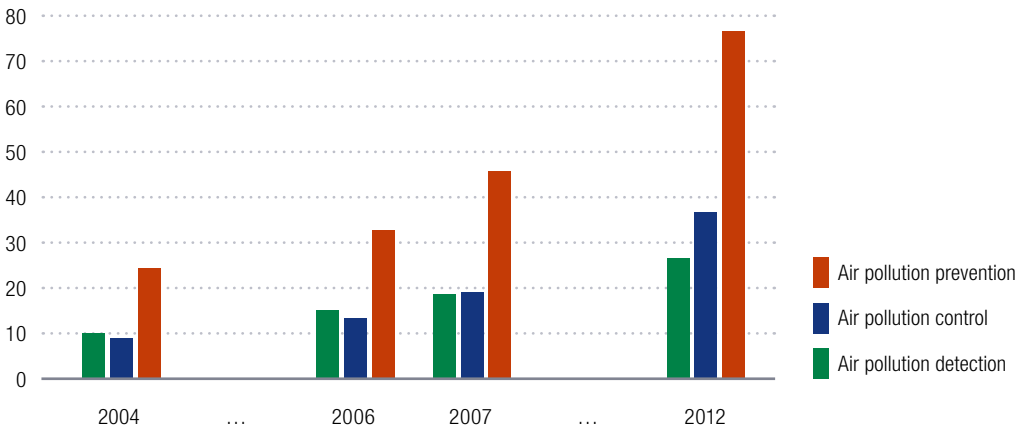

The U.S. leads the market. European industry has established a good position but is rather fragmented, including some large groups but also many SMEs. Among the European players are Atis, Bertin, Dräger Sensors, Environnement SA, Gasoptics, Horiba Jobin Yvon, Leosphere, Oldham, Philips, Seres, Specim, Spectris/Servomex, Thales and Vojenský technický ústav.

Pollution detection uses a broad range of photonic components and systems from the ultraviolet to the infrared.

Pollution detection uses a broad range of photonic components and systems

There are three main photonic technologies used in sampling collection devices:

- One of the most widely used methods relies on ultraviolet spectroscopy, with detectors measuring the strength of absorption lines for such pollutants as sulfur dioxide, nitrous oxides and ozone.
- Fluorescence spectroscopy allows detection of extremely small amounts of pollutants such as benzene, toluene, xylene and sulfur oxides. These can be measured at parts-per-billion levels.

- Another sensitive technique is chemiluminescence, in which a reactant is introduced that selectively combines with a pollutant, producing a faint luminescence in the process. Large active areas and low noise levels are required for detectors in such applications.

The main photonic technologies used for remote sensing are as follows:

- Passive or active plume-imaging systems permit qualitative and sometimes quantitative measures. Passive imaging measures the difference in radiance between the gas and the background. Active imaging is not always intrinsically safe and requires a permit to work with the equipment.
- OP-FTIR (open-path Fourier transform infrared) can identify and measure more than 100 compounds simultaneously at a distance of from 500 to 1000 metres but requires a large number of calibration runs.
- LIDAR (light detection and ranging) maps the location of pollution over large areas and has good spatial resolution. Its use is increasing but it can be affected by weather conditions.
- DOAS (differential optical absorption spectroscopy) is used in instruments that can measure a number of different pollutants along a single light beam up to 800 metres long. Data analysis is not easy and requires sophisticated software.
- LIBS (laser-induced breakdown spectroscopy) utilises a highly energetic laser focused to form a plasma which atomises and excites samples. It is used to detect soil pollution.
- Space-based environmental monitoring, both for tracking pollutants and for weather and climate analysis, makes greater demands on detectors, both for sensitivity and for compactness.

Among the many emerging needs in pollution detection are:

- characterisation of aerosols (chemical, size, concentration);
- remote leak detection (few hundred metres, 1 to 10 ppm);
- compact and portable systems for multi-gas measuring;
- compact and portable systems for soil pollution detection;
- new substances and chemical parameters to be measured in water;
- networked sensors with continuous measurement;
- long-range active imagers.

Emerging needs and trends in pollution detection

Driving assistance

The statistics on road accidents are alarming. Each year nearly 1.7 million people in the EU are injured in 1.3 million traffic accidents and more than 42 000 people die as a result (Figure 4.5.9). There are more and more vehicles on the roads and traffic situations are more complex. In the northern countries, especially, darkness and harsh weather conditions during a large part of the year make driving a risky activity.

For these reasons, because of the growing numbers of elderly drivers, driving assistance systems have come into focus. The main types are:

- driver vision enhancement (DVE) systems, usually a synonym for automotive night vision systems, that use far- or near-infrared systems;
- surveillance cameras to detect driver drowsiness and passenger body position (for airbag control);
- breath alcohol ignition interlock devices (BIID);
- collision avoidance systems;
- ice detectors for sensing slippery roads.

Each year there are more than 42 000 traffic fatalities in the EU

Figure 4.5.9 Annual number of fatalities, injuries and accidents involving casualties (EU-25), 1996 – 2005

Source: CARE (EU road accident database), national publications⁴

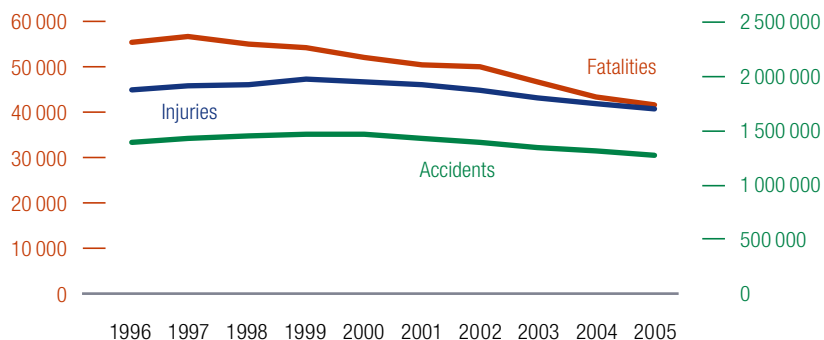

Most of these systems can use either photonic or purely electronic solutions. DVEs all use photonics. Automotive night vision systems can be either passive or active, the former using far-infrared and the latter near-infrared (a light source and an imaging detector). They have both advantages and drawbacks. Passive systems use uncooled infrared cameras which usually employ microbolometers. The technology was originally developed for the military and the main challenge is to keep down the costs of producing the detectors. In order to do this, innovative technical solutions are needed for the design of the detector and for the fabrication process.



Fig. 4.5.10 A driver vision enhancement system for pedestrian protection © BMW

⁴ http://ec.europa.eu/transport/roadsafety_library/care/doc/safetynet/2007/sn-1-3-asr-2007_final.pdf



Fig. 4.5.11 A night vision system for pedestrian safety
© Siemens

The automotive market for photonic systems includes 17 million vehicles a year in Europe alone. Both near- and far-infrared systems are available today as stand-alone systems for DVE and blind spot detection (Figures 4.5.10 and 4.5.11). However, today's consumer DVE systems are too expensive (around €2000) and the focus must be on cutting costs. Another approach is to extend the functionality of the system to warn the driver of dangerous situations ahead. In the longer term, the system could function as a collision avoidance system with autonomous braking and triggering countermeasures, such as airbags, where an accident is unavoidable.

DVE and collision avoidance

Driver vision enhancement systems are expected to grow at more than 40% CAGR in the U.S. and more than 60% in the rest of the world (including Europe). It is the fastest-growing market segment for uncooled infrared applications (the other segments are expected to grow by only 15 to 18% CAGR).

Driving under the influence of alcohol is one of the major reasons for the large number of fatal traffic accidents every year. At present, alcohol interlocks are used mainly for repeat DUI offenders, but also in quality assurance programmes for taxis and school buses. About forty thousand interlocks for commercial applications have been installed in Sweden alone. Interlocks will soon be installed in school buses in France and there are programmes running in Japan and the U.S.. One example is the initiative led by ACTS in the U.S. aiming for a massive introduction of unobtrusive alcohol sensing systems.

Alcohol sensors (BIID)

Today's interlocks use fuel-cell or semiconductor technologies, though there are shortcomings in reliability and cost. New infrared systems are under development and are expected to take a significant share of the market especially for high-volume, low-cost applications.

It is estimated that three million (5%) new vehicles in 2015 will be fitted with alcohol sensing systems or interlocks (or both) and nine million (15%) in 2020. We can expect at least half of these to be based on infrared technology.

Figure 4.5.12 World market forecast for uncooled infrared systems (U.S. excluded)
in billions of USD Source: Maxtech Int. (2008)

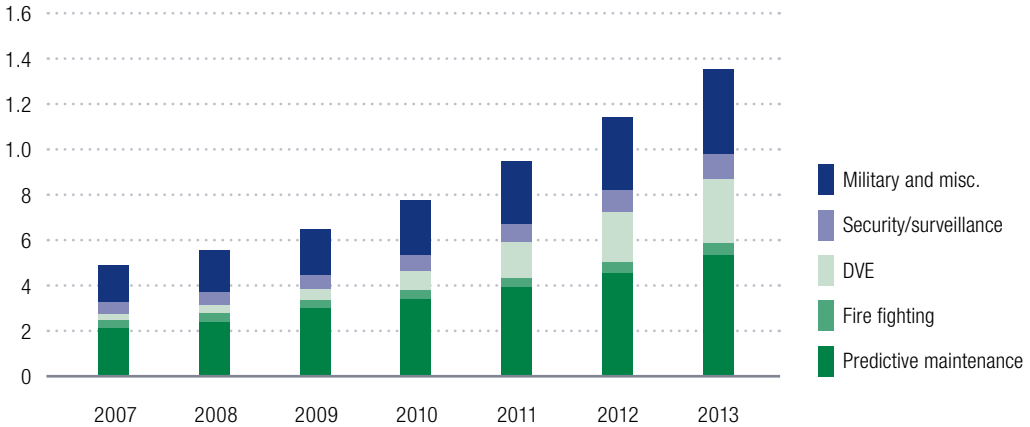

Drowsiness detection

Drowsiness has been identified as a contributing factor in up to 12% of traffic accidents.⁵ Drowsiness systems issue a warning if they sense that the driver is becoming too tired to drive safely. They monitor the movement of the steering wheel or the movement of the vehicle relative to the road.

Much of today's research efforts are to find more accurate ways to determine if the driver is getting drowsy. One approach is to use a camera system to monitor the driver's eyelids and measure how often they blink. Variation between drivers is large, however, and spectacles can cause problems. Further development of low-cost cameras and related algorithms for combining other vehicle information with driver monitoring will be necessary.

Today, about 10% of new vehicles offer drowsiness detection equipment that monitors the driver through signals from the car. The figure is expected to grow very rapidly, especially if the systems become more accurate through video monitoring of the driver.

Conclusion and recommended action

Traffic accidents are the leading cause of death and hospital admissions for EU citizens under 45 years old. With 39 000 road traffic deaths in 2008 and socio-economic costs of around 2% of GDP (€180 billion), road safety continues to be a priority area for action in the EU.⁶

The main challenge is to develop a 'low cost' uncooled infrared camera that can be used in several different driving assistance devices. New innovative technical solutions for the detector design and the fabrication process are needed to keep down production costs.

5 Dingus et al., "The 100-Car Naturalistic Driving Study, Phase II – Result of the 100-Car Field Experiment", NHTSA Report, 2006, DOT HS 810 593

6 http://ec.europa.eu/transport/road_safety/consultations/2009_11_20_ersap_2011_2020__en.htm

Technological challenges and research priorities

4.5.4

The technological challenges in photonics for safety and security use lie at two levels: the signal capture level and the equipment and system level. The following paragraphs concentrate on signal capture.

Signal capture, sensors and sources

Today's suppliers of safety and security equipment and systems normally use photonic components and technologies which have not been specifically designed for such applications. But as competition pushes manufacturers to seek better performance, demand will rise for new components such as more sensitive detectors for video surveillance at lower light levels. Therefore Europe must research and develop the basic technologies that support its already very good commercial and industrial position. Three main priorities have been identified and ranked.

1. Affordable single-photon electronic imaging

CMOS-compatible semiconductor technology, novel pixel designs and new image sensor architectures make it possible to create affordable image sensors that can detect single photons at room temperature and at video-rate readout speeds. High optical sensitivity should be complemented by very high dynamic range (exceeding 130 dB) and particularly low power consumption (only a few tens of milliwatts). The sensors should be cheap enough (a few €100 for a multi-megapixel imager) to employ in major application areas such as more intelligent cameras for next-generation video surveillance and biometrics.

2. Functional ('smart') pixels

Smart pixel concepts and designs should be developed to extend the optoelectronic functionality of conventional CMOS or CCD detectors. Of particular interest are temporal resolution with sub-picosecond timing precision, pixel-level hyperspectral and multispectral resolution, and sensitivity to polarisation. The ability to convert between analogue and digital signals within the pixel itself will be needed for more intelligent cameras for next-generation video surveillance and biometrics.

3. Specific wavelength detectors for active or passive systems and related sources

Many promising applications require high-performance sources and detectors in specific bands.

- X-ray: Compact sources and energy-resolving detectors for explosives and prohibited goods.
- Terahertz: Broadband sources and matrix detectors for detecting explosives and concealed weapons, pharmaceutical and biomedical research, and materials inspection.
- Far-infrared: Low-cost and compact imaging systems (such as microbolometers) for automotive (driver vision enhancement and collision avoidance systems) and surveillance applications.
- Near and mid-infrared: Focal plane arrays, compact and tuneable sources for various applications such as pollution detection and security.

Fig. 4.5.13 Examination of microscopic devices, especially micro-electro-mechanical systems (MEMS) © Polytec GmbH



Figure 4.5.14 Time relationships between proposed actions and the main target markets

Source: Sagem

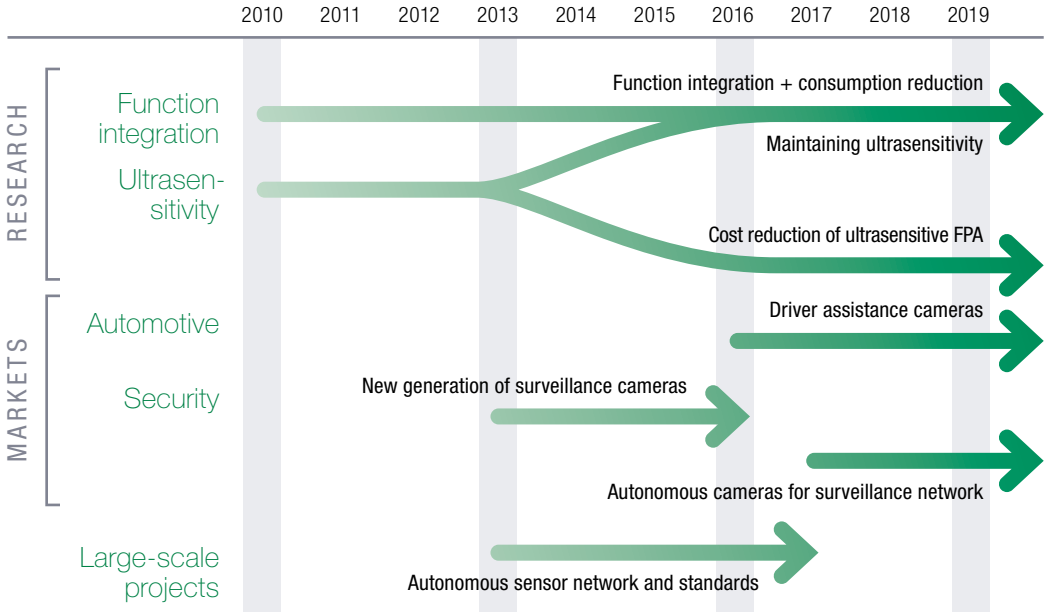

Equipment and systems

The level of equipment and systems is further described in the large scale action in Chapter 3.

Putting the vision into practice

Improvement of photonic components is a long process of many incremental changes dealing with materials and processes. Many small technological projects will be needed to realise the vision presented above at the 'signal capture' level.

On the other hand, as applications are strong drivers for development, work on the wireless sensor networks (as described in Chapter 3) will have to be started quickly. First applications will be those where a wire-free environment is highly advantageous, such as temporary working sites, large events and national frontiers, but they will spread to all types of video surveillance. This subject must be tackled in a large-scale action with a demonstration of an operational prototype.

Figure 4.5.14 shows timeline for proposed activities and the main targeted markets. ●○○

Applications are strong drivers for development such as wireless sensor networks

Management summary: Sensors for safety and security

<p>Market overview</p>	<ul style="list-style-type: none"> • €22 billion yearly market for equipment using optical technologies • Growth to €48 billion at 12% CAGR by 2015 • Double-digit growth predicted in almost all sectors <p>Security</p> <p>€15 billion in 2007 including</p> <ul style="list-style-type: none"> • Video surveillance • Border control • Biometry • Detection of dangerous and prohibited goods <p>Safety</p> <p>€7 billion in 2007 including</p> <ul style="list-style-type: none"> • Detection of pollution • Driving assistance 			
<p>Europe's position</p>	<p>Security</p> <ul style="list-style-type: none"> • People employed in European optics-driven security equipment: 45 000⁷ • Europe accounts for 30% of the world market <p>Safety</p> <ul style="list-style-type: none"> • People employed in European optics-driven safety equipment: 20 000 • Europe accounts for 30% of the world market 			
<p>Focus areas</p>	<p>Video surveillance Border Biometrics</p>	<p>Detection of dangerous and prohibited good</p>	<p>Detection of pollution</p>	<p>Driving assistance</p>
<p>Challenges</p>	<p>High image quality without supplementary illumination</p> <p>Autonomous sensors</p>	<p>Miniaturisation</p> <p>Remote detection</p>	<p>Remote detection</p>	<p>High image quality without supplementary illumination</p> <p>Embedded intelligence</p>
<p>Research priorities</p>	<p>(1) Affordable single photon imaging</p> <p>(2) Functional (smart) pixels</p> <p>Large scale project on sensor network</p>	<p>(1) Affordable single photon imaging</p> <p>(3) Specific wave-length detectors and related sources</p>	<p>(3) Specific wave-length detectors and related sources</p>	<p>(1) Affordable single photon imaging</p> <p>(2) Functional (smart) pixels</p>

⁷ Estimate by Sagem DS

4.6

Cutting-edge materials and technologies

Large-scale investments are required to develop technologies at the leading edge of current knowledge

The European Commission has recently identified a number of ‘key enabling technologies’, a set of all-purpose technologies that will support industrial deployment. Photonics is included in this set, along with nanotechnology and advanced materials, in recognition of its ability to make a major contribution to European economic development, future competitiveness, quality of life and the environment. Within the field of photonics our aim is to identify key areas of research that have the potential to improve EU industrial performance and to have a beneficial effect on society in all of the above respects. Large-scale investments are required to develop technologies that are at the frontiers of current knowledge. Supporting long-term research activities will help preserve the balance between near-mid-term and far-edge research. In photonics there has always been a strong link between basic research and technology. Further strengthening this link is a priority for the photonics community throughout Europe.

The application-oriented sections of this document provide numerous examples that demonstrate the importance of innovative device technologies and advanced materials in providing the basis for wealth creation in Europe. Many vital fields of modern engineering, including semiconductors and photonics, were built on fundamental breakthroughs in the past decades. In the same way, it is clear that there will be a set of new technology developments, not described in the applications-oriented sections, that will provide the basis for disruptive innovation across a very wide field of applications.

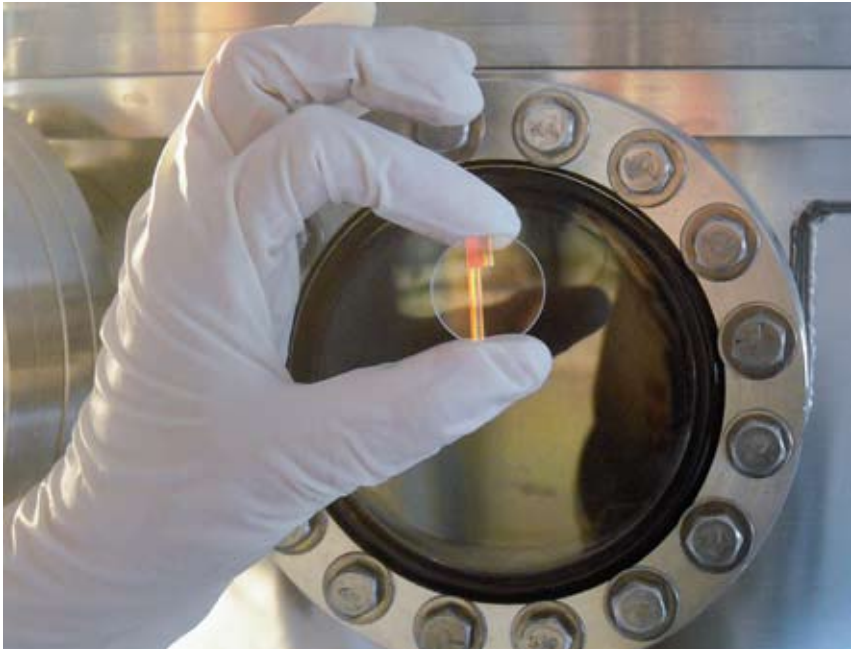

Fig. 4.6.1 Spatially variable transmission filter manufactured by radiofrequency sputtering © ENEA

We have identified two fields of research in photonics that have particular strategic importance for the European economy and society. One is emerging photonic materials; the other concentrates on new technologies and devices. In the following sections we focus on applications in fields not otherwise covered in this document and on longer-term research. Naturally the division is not always clear cut, as may be expected in a field which, although already very important economically, is still young and involved in lively innovation. The following topics do not constitute an exhaustive list and we must expect that new research areas will emerge in the future.

Emerging photonic materials

Progress in materials has always been central to photonics, with III-V semiconductors, heterostructures, ferroelectric crystals and optical fibres as important examples. The development of photonics over the past few decades has certainly been very impressive, due partly to leveraging the massive knowledge relating to silicon-based integrated circuit technology.

New photonics materials should enhance the performance of photonics and broaden its applications. This usually means improving functionality and reducing cost. In many applications one also has to address the physical size of the device (the 'footprint') and, of increasing importance, power dissipation. The following areas of materials research have been identified as being of particular significance. Many important developments will be based on synergies among various elements in this list, sometimes in combination with existing technology.

- Metamaterials (synthetic materials, mostly nanostructured). The issues here are partly theoretical, aiming to understand the electromagnetic properties and physics of the materials, but the accompanying technology development is equally important. Examples are photonic crystals, quantum dots including composite colloidal nanoparticles in a glass or polymer matrix or semiconductor media, and materials exhibiting negative permittivity or permeability or both. A major objective is to achieve lower losses than is the case for existing materials such as metals, since many important applications are currently hampered by the optical losses accompanying the special optical properties stated above. Theoretical understanding and experimental effort are both needed to overcome this crucial obstacle and allow photonics to follow in the footsteps of the electronics industry with respect to development and integration.
- Group IV photonics. This includes silicon (Si) and its combination with germanium (Ge) and tin (Sn) for applications such as modulators and light sources. The goal would be a low cost, CMOS-compatible material technology that could rival III-V materials in optical functionality and performance. Parallel research on heterogeneous integration of a variety of functional materials with silicon, again in a CMOS-compatible fashion, should also be pursued.
- Carbon nanotubes and graphene, which offer new vistas in photonics with their high absorption and mobility, complementing their use in non-photonic fields such as catalysis.
- Material engineering in oxides and chalcogenides. While these materials have been known for a long time, nanotechnology offers new possibilities to utilise phenomena such as phase changes to significantly alter optical characteristics in a way not achieved with other materials.

4.6.1

New photonic materials enhance the performance of photonics and broaden its applications

Fig. 4.6.2 A silicon wafer © IMEC



New materials, structures and phenomena offer endless possibilities for creating novel devices

- Materials for ultraviolet and mid-infrared devices and fibres, including acousto-optic materials and Faraday rotators for optical isolators.
- Organic phosphor materials for solid-state lighting, to achieve higher light conversion efficiencies than inorganic materials at significantly lower cost. The push for new and more efficient light generation will lead to breakthroughs in basic knowledge of electroluminescence in organic materials and innovations in fabrication technologies.
- Nanoparticle integration in dielectric coating matrices. This opens new horizons for the development of improved optical switches, laser concepts and sensors.
- Tremendous innovations are also expected from polymer coatings which exhibit superior functional properties for photonic devices at low cost. It is possible to modify the physical, mechanical and chemical characteristics of polymers in order to increase the functionality of optical devices. One example is including nanoparticles in the polymer matrix. Polymers also provide the key to flexible optical devices whilst the combination of polymers with semiconductor materials will give rise to novel components such as those based on optofluidics.

4.6.2

New technologies and functional devices

While new materials, new structures and new phenomena offer endless possibilities for creating novel devices, concomitant development of new technologies is also needed. There is no doubt that micro- or nano-structuring will lead to more compact and more energy-efficient photonic devices. Micro-structured fibres have already proved their value for high-power fibre lasers and shown great promise for many other applications. Nano-structured materials such as semiconductors, metal nanoparticles and carbon nanotubes have also enhanced energy conversion in thin-film solar cells.

Great progress has also been made in the use of complementary materials within the same device to take advantage of specific properties of the materials. One example is the

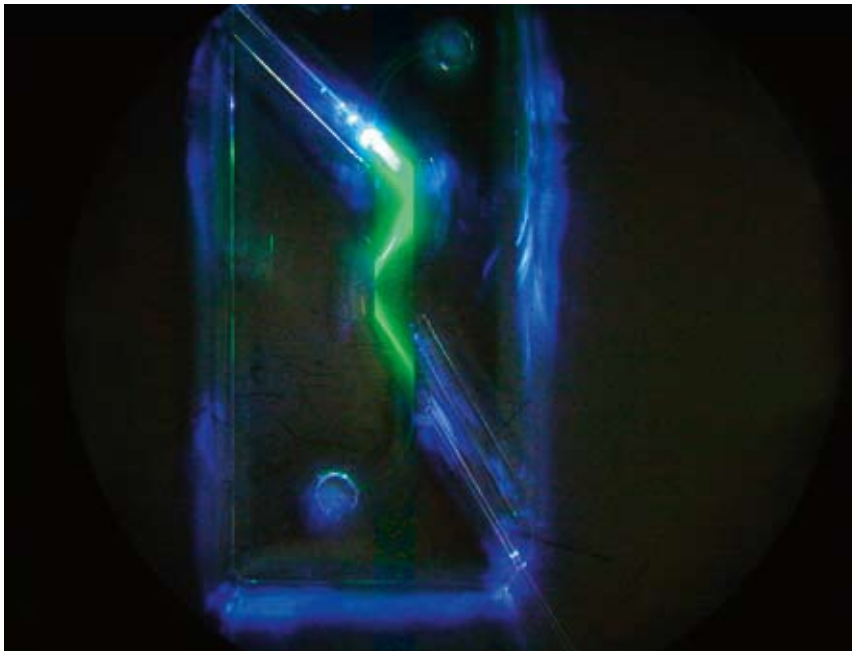

Fig. 4.6.3 Multiple internal reflectance device used as part of a 'lab-on-a-chip' © CSIC

introduction of gases, liquids, metals, semiconductors or liquid crystals into silica-based optical fibres, combining ease of splicing with low-loss connections. Another example is the photonic system-on-chip combining micro/nano-electro-mechanical systems (MEMS/NEMS), micro-fluidic and acoustic functions. In general, heterogeneous material combinations, including nanomaterials, will require the development of new manufacturing processes and additional research efforts will be needed in these fields.

Selected research areas to be addressed, related to devices and technologies and chosen on the basis of the present strengths and potential for Europe, are listed below.

- Advanced sources. Solid-state lasers are usually more efficient, more stable and often more compact and economical than other types of lasers and are finding uses nearly everywhere. Diode lasers are ideal in many applications, even for high-power industrial lasers, and advanced diode laser concepts are emerging, achieving high power together with high spatial or temporal beam coherence (or both). There is an emphasis on integrated approaches to achieve economies of scale. Nevertheless, diode-pumped fibre lasers and micro-chip lasers will be a required complement to the direct use of diode lasers, especially for reaching wavelengths in the mid-infrared. They are also needed to achieve the necessary power levels, beam quality and brilliance required in many applications, as mentioned in Section 4.2 on industrial manufacturing and quality. Ultimate solid-state laser efficiency will require the development of narrow-band, solid-state emitters and photon recycling. Growth or integration of semiconductor lasers and optics on silicon for the mid-infrared is deemed to be very important, as are femtosecond (fs) and attosecond (as) laser technology, new optical parametric oscillators, ultraviolet sources, millimetre-wave and terahertz sources, along with super-continuum sources and comb generators.
- Super-polishing of ultra-high damage threshold, ultra-low-loss surfaces to make possible pioneering technologies such as laser-induced nuclear fusion.
- New functions integrated in optical fibres (using, for example, silicon in fibres, liquid crystals, liquids, gases and highly non-linear glasses integrated in silica fibres).
- Fibre-based components for very high-power applications such as combiners, isolators, modulators and amplifiers.
- Drawn-glass integrated devices.
- Opto-mechanical devices in which optical forces induce or inhibit mechanical oscillations.
- Highly sensitive optical sensors for selective detection of molecules and bio-molecules in a gaseous or liquid environment, with integrated read-out devices.
- Nanophotonic devices allowing the convergence of photonic and electronic technologies and offering reductions in footprint, switching delay and power dissipation.

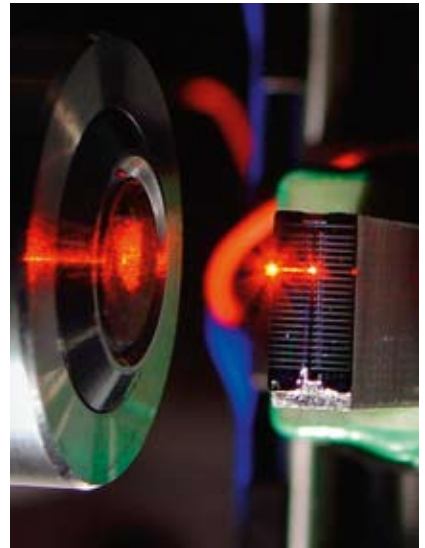

Fig. 4.6.4 Optical waveguide cantilever, light is injected through a lens and into the structure © CSIC



Fig. 4.6.5 Engineer with photonics wafer © IQE plc

- Plasmonics and nano-optics for highly integrated devices and for sensors with nano-metre-scale spatial resolution and single-molecule sensitivity.
- Adaptive optics systems based on deformable mirrors with improved reliability, compactness and cost-effectiveness.
- Miniaturised X-ray optics and X-ray phase imaging.
- Innovative dye-sensitised solar cells (DSSC) with the introduction of nanostructured materials (metal, semiconductor nanoparticles, carbon-based nanostructures).

*There is a
real need
to drive the
advancement
of basic
integration
technologies*

Integration technologies and competitive manufacturing

Photonic integration is relevant for many of these proposed ideas and thus requires a more detailed description. Over and above the application-specific, shorter-term developments detailed in the application-oriented sections of this document, there is a real need to drive the advancement of basic integration technologies, develop radically new techniques to continue to expand the boundaries of performance, functionality and cost-effectiveness, and to develop new ways of working with these technologies to realise new systems and applications concepts. The following priorities have been identified:

- Development of a new science of optical circuit research, based on design at the circuit level and including entire devices, as well, culminating in new levels of innovation in circuit functionality and complexity. This will be achieved by building upon the generic design environment and foundry platforms in InP and silicon, highlighted in Section 4.1 on information and communication.
- The density of integrated photonic circuitry is at present limited to a spatial scale of around 1 μm . This is due to the optical field confinement imposed by current waveguide technologies and by the wavelength of light in the medium. We strongly encourage developments to break these barriers and thus allow smaller and more complex circuits to be made. Important developments here include:
 - plasmonic waveguides and circuits, including applications to photodetectors, modulators and lasers (such as nano-laser arrays and circuits) as well as sensors;
 - optical circuits based on metamaterials and other novel structures; and
 - technologies to exploit the third spatial dimension in integrated optics; that is, integration of optical coating structures and fundamental research in the production of 'stem cell' coatings which hold the potential to adopt different functions by the application of different treatments.
- Integrating photonics into new semiconductor materials, especially for new spectral regions (such as visible light and the infrared region beyond 2 μm) and to improve the performance of active elements at high temperatures, thus reducing cooling requirements and power demands.
- Competitive, cost-effective manufacturing of photonics components and systems in Europe. This is a strategic objective that assures the foundation for further component innovation and development. Roll-to-roll continuous processing is a key element in this strategy and will enable photovoltaic panels to be produced for affordable renewable energy generation. Continuous processing is also key to the manufacture of commercially viable OLED lighting and displays, as reported in Section 4.4 on lighting and displays.
- New approaches to packaging and interfacing which can solve the problems of micro-alignment, coupling to external devices and optical fibres, and cost-effective assembly in a single package. This should include new technologies to allow reliable operation in non-hermetic environments, as well as scaling down conventional assembly strategies and innovative use of MEMS technology.
- Improvements in electro-optic modulators and signal processing devices through better materials, novel waveguide structures and exploitation of slow-wave effects. This will lead to higher bandwidths and lower power requirements for electrical drivers.
- Synergistic use of microelectronics to complement optical functionality and integration of electronics with photonic elements for on-chip signal routing in silicon-type integrated circuits, for example, and localised electronic processing within photonic integrated systems.

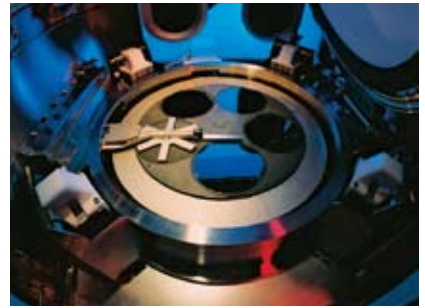

Fig. 4.6.6 IQE MOCVD reactor © IQE plc

Some topics have the potential for disruptive innovation triggering unexpected improvements in the market

Research in these areas will offer new opportunities for all the applications described in the previous sections and some topics have the potential for disruptive innovation triggering unexpected improvements in the market. ●○○



5.0

Education, training and research infrastructures in photonics

Fig. 5 Experiments
in primary schools
create an interest
in photonics © VDI
Technologiezentrum



There is a shortage of highly qualified employees in photonics

Human resources and a qualified workforce

The photonics industry in Europe employs approximately 290 000 people and there are at least as many other employees working with photonics in industries that use photonics. There are no reliable figures for the exact personnel requirements of this fast-growing industry, or for the numbers of graduates with photonics expertise available in Europe, but by universal agreement there is a shortage of highly qualified employees in photonics. In this chapter we identify the requirements for education and training, from primary school to PhD level and including learning, and suggest how industry and public authorities, as well as educational institutions, can contribute and play an active role. We also comment on the need to invest strongly in curiosity-driven frontier research to maintain and improve the level of scholarship in European universities so that graduates receive the highest level of education and training.

At a time when innovation and technology are advancing rapidly and the demand for specialists in photonics is greater than ever, education providers at all levels have to strike a balance between industry's short-term requirements and the need to provide students with a strong grounding in the physical sciences and mathematics, for example, as well as professional skills.

Primary and secondary education, typically up to age 18 or 19, focus on basic skills. Most national curricula include some elementary optics and photonics but as a rule the widespread uses and applications of photonics are not presented to students, often because teachers themselves are unaware of them. We recommend that the photonics community address this issue.

Academic education at the post-18 level is carried out in universities and at the technical level in other colleges. Technical education is more closely specialised but academic education traditionally involves the core disciplines in science and engineering, or example. We recommend in the section entitled 'Third and fourth level education' that the



Fig. 5.1 Dr. Sporea, Director of the Centre for Science Education and Training National Institute for Laser, Plasma and Radiation Physics, Bucharest, introduces the magic of the 'laser light' during a demonstration at a kindergarten in Râmnicu Vâlcea © National Institute for Laser, Plasma and Radiation Physics, Bucharest

more traditional academic disciplines include photonics, and that there be an increase in the number of specialist photonics degrees offered, both academic (in universities) and technical (in other colleges). PhD education in photonics is relatively strong in Europe, involving industry where appropriate, but could be strengthened with industry mentoring and through other initiatives in innovation and entrepreneurship.

The pace of technological change demands a workforce whose education and training is a lifelong process. We recommend that regional clusters take a key role in lifelong learning in photonics, engaging with specialists from both universities and industry to deliver courses, incorporating general approaches defined at the European level.

The photonics industry has a key role to play in education and training. It must articulate its needs to public authorities in realistic and precise terms and be more proactive in its interaction with education providers at all levels. Direct sponsorship, scholarships and prizes for students would raise the profile of photonics.

Since education and training are very largely state-funded, regional, national and European public authorities have a responsibility to establish the needs of society and industry in photonics. There is an urgent need to gather accurate data on industry's current and projected requirements, and on the courses offered by education providers (see the section on 'Photonics education and training'). At the regional level, public authorities should promote and support industry clusters, as they play a key role in the link between industry and training.

Finally, we emphasise that the highest level of scholarship in educational institutions is essential if Europe is to continue to be at the forefront of photonics innovation. Almost every major innovation in photonics (the laser, fibre Bragg gratings, photonic crystal fibres, metamaterials...) was the result of basic research driven by curiosity. With the ever-decreasing time between new discoveries and commercial exploitation, it is important that researchers be encouraged to pursue new ideas and concepts in optical physics and photonics, free of the culture characterised by mission-oriented milestones and deliverables. This highest level of scholarship will provide the best environment in which to educate and train future photonics innovators.

Role and contribution of industry

The enabling role of photonics means that 'industry', in the context of education, training and research infrastructure, must be understood to encompass not only companies whose core business is photonics (laser manufacturers and optical component manufacturers, for example) but also companies for whom photonics plays a key part in their business (medical device companies and semiconductor companies, for instance). This is of particular importance for education and training, since photonics knowledge and skills are required by those working in both photonics applications and in the core business. Furthermore, many people working in photonics applications need multi-disciplinary to let them understand the context of photonics in, for example, the healthcare and manufacturing industries. The term 'industry' in this chapter includes both the core photonics companies and the applications companies.

Industry has to play a strong role in assisting and promoting education and training, addressing three target groups: government and public authorities, education and training providers, and individuals.

Throughout Europe, education and training are funded to a large extent by government. It is therefore important for industry to articulate its needs to government and to those public authorities with responsibility for education and training. This applies at the international level in making industry's requirement clear to the European

We should increase the number of specialist photonics degrees

Direct sponsorship, scholarships and prizes for students increase the profile of photonics

Employees in photonics applications need multi-disciplinary training

Government and public authorities

Commission, for example, and also at national and local levels. Without a clear statement of industry's requirements for training and education, which often has to be quite local or regional, government cannot allocate the financial resources necessary to meet the demand.

Education and training providers

Industry can be proactive in supporting education and training providers (universities, technical colleges and schools) by

- serving on advisory boards;
- providing entrepreneurship courses and skills;
- assisting in the selection of students for industry-related projects;
- providing equipment;
- offering visits and field trips;
- offering undergraduate projects and
- providing short courses and/or master classes in specialist topics.

Individuals

The principal action that industry can make on behalf of individual students is to provide direct financial support such as sponsorship or scholarships. This is essential to attract bright students from around the world to European photonics in order to fulfil the growing needs of research and industry.

Although individual companies can address all three target groups, effective contributions can be made through regional industrial clusters and through national and international organisations such as Photonics21. Several industrial clusters already provide local training and this could be greatly extended throughout Europe. At the international level, Photonics21 is acting as a collecting point for information about internships throughout Europe and this programme could also be expanded.

Regardless of the route to involvement with education and training, the photonics industry as a whole must be considerably more proactive than at present: as educators know, it is not always easy to obtain any significant business involvement in education and training, as each company is focused on its own business. At the technician level, there is a need to create a common syllabus for the new skills that industry has to develop.

A combined university-industry PhD should be adopted throughout Europe

The photonics industry has a stronger interest in engaging in R&D projects. In several countries there are formal funding mechanisms that involve the training a PhD research assistant in a project with industry, often involving a secondment to the company for a period. This combined university-industry PhD should be adopted throughout Europe by way of appropriate funding mechanisms.

Role and contribution of public authorities

When it comes to education, training and research infrastructure, public authorities play a pivotal role in supporting initiatives and designing programmes. A commitment by public authorities at European, national and regional levels is required to better support photonics and bring it into mainstream education and vocational training. This would send a clear signal that the strategic importance of photonics is fully understood in the light of the needs of society.

The photonics community suggests that public authorities face four major issues:

- support innovation to turn research into products;
- attract and develop a qualified workforce;
- promote and facilitate lifelong learning;
- address the lack of education in basic optics and photonics.

The photonics community has identified three key factors in addressing these issues:

- industry involvement is beneficial to the students and to the quality of the research;
- education in science and optics in primary and secondary schools raises interest in these subjects;
- clusters play a decisive role in improving knowledge transfer and mobility.



Fig. 5.2
PhD students at work
in the CNR-INFM
ultra-fast photonics
laboratory at the
Physics Department
of the Politecnico
di Milano, Italy
© Politecnico di
Milano

Photonics education and training

Photonics is an interdisciplinary subject requiring knowledge and expertise from several fields including physics, materials science and computer science. Depending on the application, it may also need a good understanding of engineering, biotechnology, nanotechnology, electronics or medicine. However, the photonics community is keen to stress the importance of specialised photonics education and training to support the growing need for a qualified and highly skilled workforce in the optics and photonics industry. The notable improvement in photonics education in Europe over the past few years is encouraging and provides a solid basis for the future. However, there is still room for improvement and the European Union can play a major role in promoting photonics education and training at European, national and regional levels.

At the [European level](#) there is still a need for greater transnational cooperation in order to establish a European Research Area in photonics. For example, over the past five years several Master's of Science curricula in photonics have been established under the Erasmus Mundus programme, letting both EU and non-EU students participate in international photonics courses. In a similar vein, specific funds should be granted to photonics students at PhD level. We support extending the Erasmus Mundus programme to international PhD education, with industry participation where appropriate.

At the [national level](#) heightened awareness of and basic education in optics should be promoted at all levels, including primary and secondary education. This would ensure that teaching materials are in the local language and fit into the specific national context. Optics has a long history in European research. This makes it important to communicate it to children in a meaningful and enjoyable way. National authorities also play a key role in promoting undergraduate level courses in optical science, including vocational training.

At the [regional level](#) the photonics community is keen to build upon the photonics clusters that have developed across Europe in an effort to structure R&D and link industry more thoroughly with academia and research organisations. The community believes that regional clusters bringing together industry, academia and public authorities play a

*There is a
need for more
transnational
cooperation*

Heightened awareness of and basic education in optics should be promoted at all levels

crucial role in encouraging the involvement of public authorities at the local and regional levels and better equipping research and academia to meet the needs of the economy. Public authorities can engage the research and industrial communities in mutual learning at cluster level by funding internships, mobility and lifelong learning.

Therefore the photonics community recommends that public authorities:

- conduct a survey of the European universities and offer optics- or photonics-related courses and quantify the number of graduates they expect to produce;
- conduct a survey of photonics-related industries to explore new and missing skills and thus develop new education and training opportunities;
- encourage education in photonics for the benefit of the photonics industry, launch awareness-raising campaigns in primary and secondary levels, install optics courses at undergraduate level, and support transnational PhD programmes in photonics;
- build upon successful transnational initiatives to promote student mobility (within and outside the EU);
- outline best-practice models for public authority involvement at regional and cluster level.

Primary and secondary education

The decision for or against a career in science and engineering is often made very early in life. Some educational systems in Europe require children at the age of around 15 to specialise either in natural science or other fields, such as humanities, a decision that very often sets the direction for their entire professional lives. Even if secondary school students decide to take advanced classes in physical sciences, their education in photonics can end with the work of Planck and Einstein. This reflects the state of the art a century ago and is unlikely to attract many young people to study this subject at university. Only in exceptional cases do school pupils learn about light-related technologies

developed within the last fifty years, such as the laser, fibre-optic communication (that drives the internet), DVD optical storage, liquid crystal displays or modern LED lighting. However, the same young people use these technologies every day. In comparison, the similarly young field of genetic engineering is much better represented in European curricula, although far fewer people directly employ this technology.

Teachers as well as those writing the national curricula are often not aware of the importance of photonics in a society driven by technology. Too often, teachers themselves do not understand the applications of modern photonics. They need training and adequate equipment before they can teach their students about up-to-date technologies.

Several committed individuals and institutions have launched initiatives to provide such support to schools. They invest time, effort and financial resources in order to bring photonics into the classroom. However, the impact of their efforts remains too local and too brief. The European photonics community needs a coherent and better coordinated approach to improve the way

photonics is taught in primary and secondary schools. With the pan-European job market in mind, it is increasingly important to give students all over Europe an equal opportunity to learn about career options in photonics. A coherent outreach programme could then help universities and companies to attract students and employees from a far wider area than local initiatives can reach. Such initiatives would strongly benefit from

Photonics is important for a society driven by technology



Fig. 5.3 A girl in Wilcannia, New South Wales, discovers how optical fibres work © Vrije Universiteit Brussel



Fig. 5.4 A group of students sets up an optical illusion © National Institute for Laser, Plasma and Radiation Physics, Bucharest

greater coordination at the European level to provide continuous communication about important developments in photonics. New science teachers, in particular, should know about the importance of photonics before they start working in schools. This organisation should therefore launch activities in those institutions where future generations of teachers are educated. It could also support experienced teachers with a job development programme, offering teacher training courses on photonics within the existing national frameworks.

Photonics kits are another important way to improve photonics education in primary and secondary schools. Children have a better opportunity to recognise their own abilities and talents in science and engineering if they can experience the excitement of working with light with their own hands. Pupils should be shown how optical phenomena translate into interdisciplinary applications that transform their everyday lives. By sponsoring this programme, the photonics industry can demonstrate its serious interest in the long-term improvement of photonics education in schools. European and national photonics associations should be actively involved in this programme.

Photonics kits improve education at primary and secondary levels

Third and fourth level education

Third level education refers to that normally offered to school leavers at age 18 or 19, and fourth level to PhD education. Third-level education may be technical or academic. Despite the Bologna agreement, which aims to harmonise the plethora of qualifications throughout Europe, there is little uniformity from country to country, either in the education system or the names of the qualifications. For the purposes of this chapter we shall refer to:

- technical certificate, for technical training courses, typically taking one to three years;
- bachelor's degree (e.g. BS, BSc, BEng), for university level academic courses of three to four years;

- master's degree (e.g. MS, MSc, MEng) for post-bachelor's courses taking one to two years;
- PhD, for research degrees, lasting for three to five years.

In some countries master's degrees may be earned either via coursework (lectures, practical and project work) or purely through research.

Technical certificate level

Third-level technical education (non-academic) is provided by technical colleges and vocational schools offering qualification courses of one to three years' duration and which cater for either school leavers or experienced workers seeking additional qualification. These qualifications are vocation-oriented and designed for entry-level employment, so the content is mainly related to practice in certain fields of technology such as mechanics, automotive or electronics. As photonics is underrepresented at this level, employees working in photonics have to obtain specialised knowledge on the job.

We should develop certified courses in photonics

To avoid a shortage of skilled personnel that could hinder the growth of the photonics industry, we recommend bringing photonics into the curricula of third level technical education. Beyond that the development of certified courses in photonics should be taken into consideration. As prescribed in the Copenhagen Process¹, these activities are to be coordinated Europe-wide to assure transparency and comparability.

The availability of training in photonics at the technical certificate level varies widely across Europe. Technical schools at post-secondary level (such as BTS or IUT in France and the *Fachhochschule* in Germany) can offer some training and education in fields related to photonics but there is a need to improve the framework and subjects available at these centres.

Bachelor's degree level

The majority of people whose career develops into some aspect of photonics holds a bachelor's degree or equivalent in a basic science or in engineering. Although these degrees are not intended to produce specialists in photonics, all students enrolled in these programmes should have the opportunity to study sufficient photonics to enable them to move on to postgraduate studies in the subject or to take up employment in photonics companies. To this end, the programme should offer a number of photonics courses with laboratory experiments. In the interests of a balanced education such courses should not dominate the curriculum (except for the specialist courses described below), and therefore our recommended guideline would be to offer at least one photonics course per year. The academic content of this course should be a balance between theory and applications, in order to put photonics into a practical context.

Others who pursue a career in photonics have graduated from specialist undergraduate degree courses in photonics. These courses focus on both basic science and photonics. There is a general consensus that a number of such specialist photonics degree options should be available in every country in Europe, recognising that the most common route to a career in photonics will be through courses in basic science or engineering.

In all cases, bachelor-level courses should include the opportunity for students to take one or more courses in business, innovation and entrepreneurship, and these courses should always be supported with the active involvement of industry and commerce.

1 The Copenhagen Declaration is the basis for European co-operation in the field of Vocational Education and Training (VET). A central part of the process is the development of common European frameworks and tools to enhance the transparency, recognition and quality of competences and qualifications, making the mobility of learners and workers easier. See http://ec.europa.eu/education/vocational-education/doc1143_en.htm.

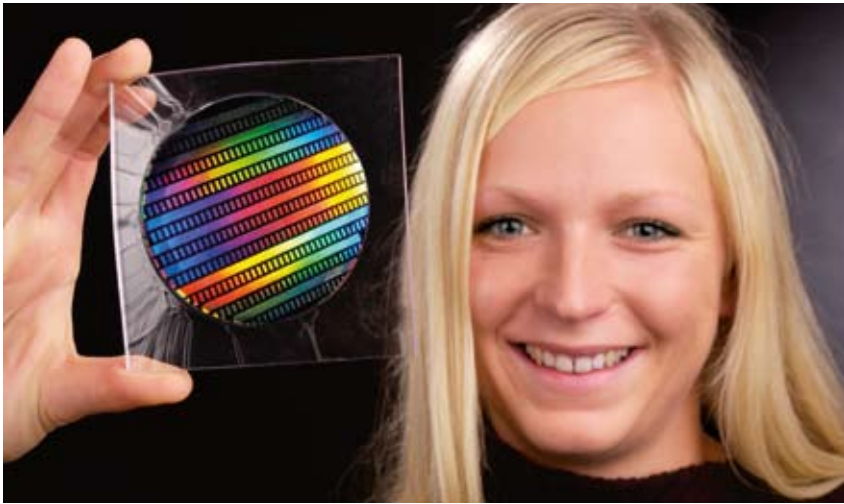

Fig. 5.5
 Growing interest in photonic studies and master's programmes will increase the skilled workforce © University of Freiburg

Master's-level specialist courses in photonics have been offered for decades at a small number of universities (for example, Institut d'Optique Graduate School, Paris, and Imperial College, London) and new high-level courses have recently been established (such as Abbe School of Photonics, Jena). These courses have been supplemented by European-level cooperation through the Erasmus Mundus programme, with several such networks concentrating on photonics. All courses at this level have historically strong links with industry and nowadays provide optional training in innovation. With the slow but growing movement towards the Bologna model, such courses should be encouraged and supported and master's-level courses in photonics should be established in every country in the EU. The development of a master's curriculum in photonics would be a useful reference document, although there is no desire or need for uniformity, and regional needs and availability of local expertise require the curriculum to be flexible. One important aim of this curriculum would be to encourage the development of programmes covering the whole range of fundamentals and technologies that will underpin future innovation in photonics. These programmes could be developed locally or by alliances of several universities with

Master's degree level



Fig. 5.6
 Europe offers several master's programmes in photonics © Max-Born-Institut

Master's-level courses in photonics should be established in all the EU countries

complementary strengths. This is essential if the growing needs of industry in the various aspects of photonics are to be satisfied. This also addresses the needs of master's candidates for an education that opens up many career opportunities in the long term.

In addition to specialist master's courses in photonics, there is a need to include photonics skills in other technological master's degrees – a knowledge of laser machining, for example, in a master's-level course on production. The ubiquitous role of photonics in industry and society requires photonics knowledge to be shared with a wider group than photonics specialists alone.

PhD degree level

The PhD degree is usually taken after a master's-level course (as recommended in the Bologna agreement) but in some countries it can be taken straight after a bachelor's degree. The primary purpose of this degree is to allow the student freedom to develop as an independent, creative researcher, and there is a strong consensus in the academic community that the research thesis is by far the most important element of this degree. There is also agreement that some element of academic coursework may be desirable (in particular for students who have not taken a master's in photonics) and also that courses in professional skills (presentation, writing, time management and so on) are essential. Optional courses in business, innovation and entrepreneurship should be offered for those researchers with an interest in this direction. All courses in innovation should involve the active participation of industry, particularly SMEs and entrepreneurs in photonics.

Lifelong learning

Formal education and training is a process that is usually completed by the age of 18 to 30, depending upon the level to which it is pursued. However, the need for education and training lasts throughout a person's working life (and probably beyond). This is true at both the professional level ('continuing education') and technical level ('lifelong learning'), where the latter helps industry and individuals improve their competence and competitiveness.

Within Europe there is a wide variation in the level and quality of lifelong training available to employees, whether in mainstream photonics companies or in photonics-related companies. We need to establish Europe-wide lifelong training opportunities, based on existing examples of best practice, though continuing education at the technicians' level may have to be conducted in the local language.

The pace of change in science and technology requires a workforce that is continually acquiring new knowledge and skills. Given the need for European industry to invest in continuing education for its employees, solutions requiring some element of financial

incentive or legislative action from national or regional public authorities are called for. These are already available in some regions but need to be extended throughout Europe, and the photonics community needs to take full advantage of existing incentives.

We propose that the most effective means for providing continuing education to employees in European industry is via regional clusters, which can enlist the assistance of both companies and universities for the delivery of the course material. Focusing on clusters makes it possible to address local needs. Networks of clusters should coordinate the course material and content and enable best practice to be distributed to all clusters.

Frontier research strategy

A feature of photonics is the strong link between leading-edge research, technology and applications; there is a functioning

Fig. 5.7 A skilled workforce in photonics will lead Europe into the future
© Laser Zentrum Hannover



continuum from frontier research to commercial products. If we are to compete globally we need to promote frontier research as well as industry-related research. To this end, we believe that a cultural change in research funding is desirable in many funding bodies, one which pushes curiosity and imagination. Breakthroughs in fundamental science are highly unpredictable and most often occur either through curiosity-driven research by creative scientists or by fortuitous discovery, allied to keen observation and interpretation. As we approach the fiftieth anniversary of the invention of the laser – LaserFest celebrates this in 2010 – it is appropriate to recall that this innovation, which has totally transformed science, technology and society, arose from curiosity-driven research, not strategic R&D. Indeed, the mentality of strategic R&D, with its culture of milestones and deliverables, is the exact opposite of basic research, where advances cannot be programmed or predicted. There are many examples of frontier research leading to commercial exploitation in photonics, including Bragg gratings in optical fibres, super-continuum generation in photonic crystal fibre and electroluminescent polymer LEDs.

New, additional funding models or instruments may be needed to meet this challenge, both at national level and in the European Framework Programmes. In order to better characterise and define the funding strategy for frontier research in photonics, research proposals must have the potential to make a considerable long-term impact on the strategic agenda of the Photonics21 working groups, together with significant innovative knowledge content. This should ensure on the one hand that frontier research is linked to targeted technologies without, however, neglecting the needs of pure frontier research itself. Some areas of great potential were described in a report from WG7 by Photonics21.²

Frontier research leads to commercial exploitation in photonics

Changes in science and technology require a continually learning workforce

Recommendations

1. Industry must be more proactive in engaging with education and training providers if its manpower needs are to be met. More scholarships and internships should be offered. The specific requirements at both regional and national levels must be voiced more aggressively vis-à-vis local and national governments and the European Commission.
2. Governments and public bodies must act strategically to support education and training in optics in order to satisfy regional, national and international needs.
3. Education providers at primary and secondary levels should be assisted by photonics outreach activities from universities, industry and regional industry clusters to include modern applications of optics and photonics in national science curricula. Industry should provide equipment for educational kits.
4. European outreach activities in photonics, at all levels, would greatly benefit from a better degree of coordination. A suitable organisation, possibly with infrastructures distributed across the EU, should be established with such a mandate. Materials should be available in local languages from a central website.
5. Universities and others involved in third- and fourth-level education should continue to engage with the photonics industry, particularly to help them offer courses in business, innovation and entrepreneurship. They should ensure that mainstream physics and engineering courses at third level offer at least one course related to photonics in each year of education, to emphasise both the academic and practical importance of the subject.
6. Regional clusters have a strong role to play in education and training in their local communities, particularly for lifelong learning. By supporting Europe-wide networks of clusters, the European Commission could help increase the number and quality of continuing education courses they provide. ●○○

² "Workshop on Future Areas of Research in Photonics" (October 1-2, 2007, Cork, Ireland). See also, D. Gevaux, "Charting the Future for Europe," *Nature Photonics* 2, March 2008, pp. 125–127 [doi:10.1038/nphoton.2008.07]



6.0

Implementing the Strategic Research Agenda

Conclusions

During the past four years Photonics21 has provided for an innovation environment capable of accelerating photonics research, enhancing cooperation, increasing R&D investments and mobilising a critical mass of resources throughout Europe. By establishing a constantly growing photonics community and developing a coordinated strategy, Photonics21 has led the way to technological breakthroughs in lighting, healthcare, information and communication, and the manufacturing sector within Europe. These breakthroughs will be ultimately transformed into marketable products and services that are competitive on world markets. The Photonics21 community has grown from 250 members in 2005 to more than 1400 members today. They speak as a strong voice for further innovation and development in photonics in Europe and for European society.

Industry, science and public authorities have recognised photonics as a key enabling technology for Europe, one which has the potential to respond to major social challenges. The work of the past four years has encouraged the European photonics community to follow a common approach and to address megatrends such as solid-state lighting, green communication networks, photonics-related cancer diagnosis, mass customisation in manufacturing and autonomous sensor networks. These megatrends will lead Europe to economic growth and into an energy-efficient and sustainable future.

Today photonics employs about 290 000 people in Europe and supports many more through subcontractors. More than 5 000 companies are involved in manufacturing photonics products, most of them small and medium-sized enterprises. During the last four years, the European photonics industry invested €4 billion a year in R&D. The European photonics industry is ready to further strengthen Europe as a world leader in photonics.

Public funding for photonics in the EU member states has not improved significantly over the past four years. Only three countries have meaningful photonics programmes, namely Germany, the Netherlands and the United Kingdom. Considering the economic and social impact of photonics, this is an unsatisfactory situation, especially when we see competing regions of the world investing heavily in this sector.

In September 2009 the European Commission identified photonics as a key enabling technology. This was a major breakthrough for Europe's photonics community. However, current investments in photonics within the Seventh Framework Programme, around €50 million a year, need to be increased to reflect the strategic importance of this area.

The photonics community has established several national platforms throughout Europe, including those in Italy, Greece, Spain, Switzerland, Slovenia and Poland. The establishment of national platforms in France, Sweden and Ireland is under discussion.

Photonics21 has taken responsibility for bringing together all the European stakeholders to further develop a joint European strategy focused on photonics applications. The European photonics community is willing to play its part in responding to the 'grand challenges' facing our society. However, these goals can only be achieved with the strong support and commitment of national public authorities and the European Commission. Photonics21 will continue to cooperate closely with those entities in order to strengthen transnational cooperation.

Key challenges

Building on progress to date, the European photonics industry, science and policy-makers together urgently need to respond to challenges such as energy efficiency, the ageing society, and public safety and security. During the last four years the photonics community has established the technological basis. Now it is time to focus on further applications for photonics and to support the development of new business models.

Photonics will create energy-efficient communications networks

Optical networks make possible true broadband communications virtually everywhere. Photonic systems and component technologies, both for access and for core and metropolitan networks, will be developed to support speeds of from 40 Gb/s to 100 Gb/s and beyond. Networks of the future will be wholly optical and more dynamic and so more efficient and offer a richer range of services. New, energy-efficient network architectures will make optical networks and data transmission greener than they are today. Optical networks will be the key to energy-efficient information and communication technologies of the future.

Laser manufacturing will respond to individual customer preferences

Industrial production increasingly has to satisfy individual customer preferences. Companies will focus more on 'mass customisation' and rapid production using the laser as a fast and flexible manufacturing tool. Laser systems themselves will be produced at lower costs whilst becoming much more flexible and individually adaptable. This development will be relevant for many areas of manufacturing, including photovoltaics, aeronautics and the automotive sector.

Biophotonics will support the ageing society

New solutions in biophotonics will play a key role in Europe's ageing society. Their application in life science and medicine will help to detect and treat serious diseases such as cancer and eye diseases more efficiently and reliably. Biophotonics will also be used to gain more precise understanding of the origin of diseases in order to prevent them. Future healthcare will focus on personalised medicine which responds to the needs of individual patients. These developments will contribute to a more efficient healthcare system and help contain the rising costs of caring for an ageing population.

Solid-state lighting will improve energy efficiency

Europe must lead the transition into the era of solid-state lighting in order to contribute to an energy-efficient future. Next-generation light sources such as LEDs and OLEDs will be more efficient and more cost-effective than today's technologies. To preserve and strengthen the leading position of our lighting and luminaire industry, we must make sure that new energy-efficient light sources are produced in Europe. As lighting will become even more important in the future, Europe must take a comprehensive approach to developing innovative lighting solutions — from research, through deployment and to the market.

Photonic sensors will enhance safety and security

The future development of optical components and sensors will further improve driver assistance systems and so make our streets and roads safer. Photonic components will also be used to detect pollution of the air, water and soil, making the environment cleaner and safer. Photonic sensors for biometrics and for baggage screening will improve security at airports and railway stations. Autonomous sensor surveillance networks will protect borders and other sensitive areas.

Educational materials will encourage young people to study photonics

Education and research in photonics is a key issue for industry, science and public policy. Europe must take immediate action to overcome the current shortage of qualified employees in photonics in order to stay competitive with Asia and the United States. Distributing educational material to schools, in several European languages, via the internet and providing photonics products for educational kits will stimulate broader interest in photonics and increase the number of photonics students in Europe.

Attractive master's programmes will retain expertise in Europe

Europe offers several master's programmes in photonics. Today, many non-European students participate in these curricula and Europe will lose their skills when they go back to their home countries. One of the challenges for the EU member states is to make these master's programmes more attractive to European students so that knowledge about photonics will stay in Europe and strengthen the development of photonic technologies. Companies should also cooperate closely with academia to offer business-relevant courses on entrepreneurship and industrial case studies.

Internships will help train a skilled workforce

The photonics community will offer more internships and publicise them more widely. Industry will take on the role of mentor to train young students in internships during their photonics studies. Also of importance are increasing cooperation between companies and universities and supporting student internships in commercial firms. This will lead to an improved exchange of findings and knowledge in photonics research relevant to industry.

Key recommendations

On the basis of these key challenges, the photonics community has drawn up the following seven key recommendations which are addressed to the photonics industry, research institutions, the EU member states and the European Commission. They refer to actions which should be taken at a European level to prepare the way for future applications of photonics.

1. We must establish effective instruments for photonics

The European photonics community urgently needs effective instruments which combine transnational research with demonstrations of new technologies. These instruments will help the photonics community achieve its goals and respond to the pressing needs of society. Strategically relevant areas, such as solid-state lighting, need a large-scale, joint effort between industry, academia and public authorities. Such instruments would support development from basic research through to deployment and the market launch of products. European funding in photonics should combine research and deployment more strongly.

2. EU member states should set up photonics programmes

The EU member states should increase their national investments in photonics. Although countries like France, Italy and Spain have a particularly strong industrial base in photonics they have not yet set up national funding programmes that address the field as a whole. Many member states have world-class scientific excellence in photonics but national strategies are needed to translate such excellence into marketable products. Member states should further enhance cooperation with their European partners and support transnational research to bring together distinguished partners from industry and academia.

3. The European Commission should double its funding for photonics

Photonics is a key enabling technology in Europe. EU funding is directed to those research topics which are riskier or take longer than what industry could normally support, but which are still vital for the future of the photonics industry. It also facilitates greater cooperation amongst players at European level than would otherwise occur. However, the current budget dedicated to photonics by the European Commission does not match the field's strategic importance. This budget supports several sectors where there is significant market potential, but does not achieve the critical mass needed for leadership in any one of these sectors. Europe needs to at least double its public investment in photonics.

4. The photonics industry should invest 10% of turnover in R&D

The European photonics industry is especially supportive of short- and medium-term research which is vital for bringing new products to market. Investment in R&D is essential for European companies to stay competitive. The photonics industry should be prepared to increase its investment in R&D to 10% of its overall annual turnover, or some €5 billion. This will stimulate and support research and deployment in lighting, healthcare, information and communication, safety and security, and industrial manufacturing.

5. SMEs should have access to a capital fund for photonics

The further development of the photonics industry in Europe depends on improved access to capital markets, especially for SMEs with limited capital resources. Flexible financing concepts for industrial photonics are needed which respect the special needs of SMEs during the seed and growth phases. A dedicated European industrial photonics seed and growth fund providing long-term financial support would be a suitable instrument to foster growth in industrial photonics. Such a fund could also ensure the supervision and support needed by management at start-up companies. Financing could be provided by the European Investment Bank in cooperation with investment banks in the EU member states.

6. We must cooperate with other parts of the world to develop green photonics

EU member states and the European Commission should set up a framework for international cooperation especially with the United States. This cooperation should concentrate on selected areas in green photonics, principally solid-state lighting and photovoltaics. Close international cooperation will drive further advances in R&D and stimulate the growth of the photonics industry. It will also set the standards required for widespread adoption of the new lighting and photovoltaic technologies.

7. We must work together to develop a skilled workforce for photonics

Estimates indicate that, in the next ten years, Europe will need 80 000 new and qualified experts in photonics to cope with rapid industry growth and the retirement of skilled workers. EU member states, public authorities and the photonics community should pool their efforts so as to develop a workforce with the skills needed to meet the challenges of the future. If photonics is to thrive in Europe, then we have no alternative. ●○○



7.0

Glossary

adaptive optics	Optical systems that improve resolution by compensating for distortions in the optics.
autofluorescence	Fluorescence arising from fluorophores naturally present in living cells.
biophotonics	Photonics as applied to healthcare, life science and biotechnology.
broadband	Any of a number of technologies used to provide internet access at speeds significantly faster than are possible using a dial-up modem.
chalcogenide compounds	Compounds containing elements of group VI of the periodic table. Chalcogenide glass is transparent to infrared light and can be used to make fibre optics to transport infrared laser beams.
charge-coupled device (CCD)	An imaging sensor array commonly used in digital cameras and other imaging devices.
chemiluminescence	The emission of light resulting from a chemical reaction.
CMOS	Complementary metal oxide semiconductor, a technology used for making integrated circuits.
coherent anti-Stokes Raman spectroscopy (CARS)	A technique developed from Raman spectroscopy which is several orders of magnitude more sensitive and thus suitable for examining biological materials.
computed tomography (CT)	A medical imaging technique that uses X-rays to build up a cross-sectional image of part of the body.
correlated colour temperature (CCT)	A measure of the quality of 'white' light emitted from a source, expressed as the temperature of a black body of the same colour.
differential optical absorption spectroscopy (DOAS)	A technique for measuring trace amounts of polluting molecules in the atmosphere.
digital microscopy	The use of an optical microscope with a digital imaging system such as a charge-coupled device .
diode laser	A compact laser based on a semiconductor diode.
disc laser	A high-power, solid-state laser based on a very thin laser medium which can be efficiently cooled and allows for high brilliance.
dynamicity	The ability of a telecommunications network to automatically manage and control its own connections.

efficacy	A measure of the effectiveness of a lamp in converting electrical power to light. It is measured in lumens per watt (lm/W).
fibre laser	A laser constructed within an optical fibre.
fluorescence	The emission of light of a longer wavelength (lower energy) than the light absorbed. Most commonly an object exposed to ultra-violet light will fluoresce in visible light.
fluorescence endoscopy	A technique using fluorescence to diagnosis cancer within the body.
fluorescence life-time imaging microscopy (FLIM)	A technique of fluorescence microscopy for identifying parts of a specimen by measuring the time taken for fluorescence to fade.
fluorescence microscopy	A microscopic technique that employs fluorescence to study selected parts of a specimen.
fluorescence recovery after photobleaching (FRAP)	A technique in fluorescence microscopy for measuring the ability of a fluorescent molecule to move within a film or membrane.
fluorescence resonance energy transfer (FRET)	A technique in fluorescence microscopy for identifying where and when molecules with two different fluorophores are interacting with each other.
fluorophore	A molecule with fluorescent properties, often used as a label.
Gb/s	Gigabit per second, a unit of data transfer rate equal to 10^9 b/s.
green photonics	Photonic solutions that generate or conserve energy, cut greenhouse gas emissions, reduce pollution, produce environmentally sustainable output or improve public health.
Tb/s	Terabit per second, a unit of data transfer rate equal to 10^{12} b/s.
III-V semiconductors	Semiconductors formed from elements in groups III and V of the period table.
total internal reflection fluorescence microscope (TIRF)	A microscope designed to observe fluorescence in a thin surface layer of a specimen, thus avoiding being flooded by light from deeper layers.
laser-induced breakdown spectroscopy (LIBS)	A technique for analysing a sample by heating it with a laser to ionise a small amount and then observing the spectral emission lines as the gas cools.
light detection and ranging (LIDAR)	A technique analogous to radar that uses laser pulses to measure distances to objects. It can be used to monitor atmospheric pollution.

light-emitting diode (LED)	A semiconductor device that emits light.
liquid-crystal display (LCD)	A flat-panel display in which liquid crystals change opacity when exposed to an electric field.
luminaire	A complete light fixture.
magnetic resonance tomography (MRT)	A medical imaging technique that uses magnetism, radio waves, and a computer to produce images of body structures.
metal organic vapour phase epitaxy (MOVPE)	A method for depositing thin layers of crystalline materials used in the construction of light-emitting diodes .
metamaterial	A synthetic material designed to have specific properties such as a negative refractive index.
micro-electro-mechanical systems (MEMS)	Electromechanical devices on a scale of 0.02 to 1 millimetre in size.
microfluidics	A technology dealing with the movements of fluids through narrow passages, used for 'lab on a chip' applications.
multimodal imaging	A combination of different imaging techniques.
multiphoton microscopy	A technique in fluorescence microscopy where several (usually two) low-energy photons are used to cause fluorescence instead of one high-energy photon. It does less damage to living cells.
multiplexing	Any of a number of techniques for sending two or more separate signals along an optical fibre.
OP-FTIR (open-path Fourier transform infrared spectroscopy)	A spectroscopic technique for detecting molecules in air by their absorption of an infrared beam.
optical coherence tomography	A medical imaging technique analogous to ultrasound, used to obtain subsurface images at high resolution (better than 10 μm), commonly used for diagnosis of eye conditions.
organic light-emitting diode (OLED)	A light-emitting diode that employs organic compounds.
photodynamic therapy (PDT)	A treatment for cancer in which light is directed towards a tumour that has been primed with a light-sensitive chemical.

photovoltaic cell	A semiconductor device that generates a voltage when exposed to light. Also known as a solar cell.
positron emission tomography (PET)	A medical imaging technique using a radioactive tracer which emits positrons. The positrons react with electrons in the body to produce gamma rays, which are then detected.
Raman spectroscopy	A spectroscopic technique that uses the scattering of light from a specimen to identify the species of molecules present.
solid-state lighting (SSL)	Lighting that uses light-emitting diodes or organic light-emitting diodes .
terahertz (THz)	A unit of frequency equal to 10^{12} Hz.
time-division multiplexing (TDM)	A multiplexing technique in which a single signal is separated into many segments, each very short in duration.
transparency	In a communications network, a condition where all the links are optical, with no electrical conversions.
vertical-cavity surface-emitting laser (VCSEL)	A type of diode laser that emits a beam of light at right angles to the chip.
wavelength agility	The ability of an optical communications system to change the wavelength at which it operates.
wavelength-division multiplexing (WDM)	A multiplexing technique in which each signal is transmitted at a slightly different wavelength.

