

# STRATEGIC RESEARCH AGENDA

## OVERVIEW

**Waterborne Transport & Operations  
Key for Europe's Development and Future**



**WATERBORNE<sup>TP</sup>**  
WATERBORNE<sup>TP</sup>

#### DISCLAIMER

This document has been prepared on behalf of the Support Group and the Mirror Group of the European Technology Platform Waterborne.

The information and views contained in this document are the collective view of the European Technology Platform Waterborne and not of its individual members, or of the European Commission.

Neither the Support Group, the Mirror Group, the European Commission, nor any person acting on their behalf is responsible or liable in any way whatsoever for the use that might be made of the information contained in this publication.

# Table of Contents

I INTRODUCTION . . . . .	4
1.1 Achieving VISION 2020 . . . . .	4
1.2 Delivering the Waterborne Strategic Research Agenda . . . . .	6
2 KEY PRIORITIES FOR RESEARCH, DEVELOPMENT AND INNOVATION (RD&I) . . . . .	7
2.1 Safe, Sustainable and Efficient Waterborne Operations . . . . .	7
2.1.1 Implementing Goal Based / Risk Based Frameworks for Cost Efficient Safety . . . . .	8
2.1.2 The “Zero Accidents” Target. . . . .	9
2.1.3 The “Crashworthy” Vessel . . . . .	11
2.1.4 “Low Emission” Vessels and Waterborne Activities . . . . .	12
2.1.5 Enhanced Waterborne Security . . . . .	14
2.2 A Competitive European Maritime Industry . . . . .	15
2.2.1 Innovative Vessels and Floating Structures . . . . .	16
2.2.2 Innovative Marine Equipment and Systems . . . . .	18
2.2.3 Tools for Accelerated Innovation . . . . .	20
2.2.4 Next Generation Production Processes . . . . .	21
2.2.5 Effective Waterborne Operations . . . . .	23
2.2.6 Technologies for New and Extended Marine Operations . . . . .	25
2.3 Manage & Facilitate Growth And Changing Trade Patterns. . . . .	26
2.3.1 Accelerated Development of New Port and Infrastructure Facilities . . . . .	27
2.3.2 Interoperability between Modes. . . . .	28
2.3.3 More Effective Ports and Infrastructure . . . . .	30
2.3.4 Intelligent Transportation Technologies and Integrated ICT solutions . . . . .	31
2.3.5 Understand Environmental Impact of Infrastructure Building and Dredging . . . . .	32
2.3.6 Traffic Management Strategies . . . . .	34
3 IMPLEMENTATION STRATEGY . . . . .	35
3.1 Critical Enablers . . . . .	35
3.1.1 Human Resources, Education and Training. . . . .	35
3.1.2 Defending Intellectual Property (IPR) . . . . .	36
3.1.3 Political Framework: Joint Initiatives and Level Playing Field . . . . .	36
3.2 Implementation Summary . . . . .	37
4 ANNEXES. . . . .	38

# I. Introduction

The WATERBORNE Technology Platform was launched in January 2005. It builds on the successful efforts of the Maritime Industry Forum (MIF) in publishing two volumes of maritime R&D Master Plans since 1994. WATERBORNE brings together the industry stakeholders with the EU member states, the European Commission services and stakeholders from science and society. A vision of the year 2020 (Vision 2020) was developed and is now followed by this WATERBORNE Strategic Research Agenda (WSRA).

The WSRA addresses the innovation challenges in the next 15 years, summarised under the 3 pillars of the Waterborne Vision 2020:

- Safe, Sustainable and Efficient Waterborne Operations
- A Competitive European Maritime Industry
- Manage and Facilitate Growth and Changing Trade Patterns

The key priority themes for Research, Development and Innovation (RD&I) are presented under these headings. Some of these themes have an impact on more than one pillar, not only the main one they are listed under. The key research themes are not stand-alone issues, but will be integrated through innovative interdisciplinary research into larger demonstrator programmes.

## I.1 Achieving VISION 2020

Europe is a maritime superpower as has been illustrated in the Vision 2020 document. The WSRA will stimulate the growth of all the sectors within the European maritime cluster and thereby contribute to the continuation of this global leadership position. This translates into setting the quality standards for safe and sustainable maritime operations as well as the increase in the pace of maritime innovations.

European companies understand that an integral cluster approach at a European level is a critical condition for achieving the ambitious objectives set out in the Vision 2020 document. The Waterborne Technology Platform is an important step forward on the road to forge ties between European maritime companies, sectors and national clusters. The unifying force is now spreading rapidly and it will facilitate cross border cooperation, not only between leading firms, but also between SME networks. As the pace of innovation increases, the transaction costs of participating in the innovation networks will go down. More and more small and medium enterprises will be able to become part of the successful European research area. The heightened economic dynamics will translate into increased exports, employment and value added. The WSRA and the work programmes based on it, are thus an important instrument to unite the European maritime industry, embracing deep sea, short sea and inland transportation of goods and people as well as off-shore technology and recreational craft, and to defend its current and future competitive advantage.



### A European Round Table for Waterborne R&D Policy

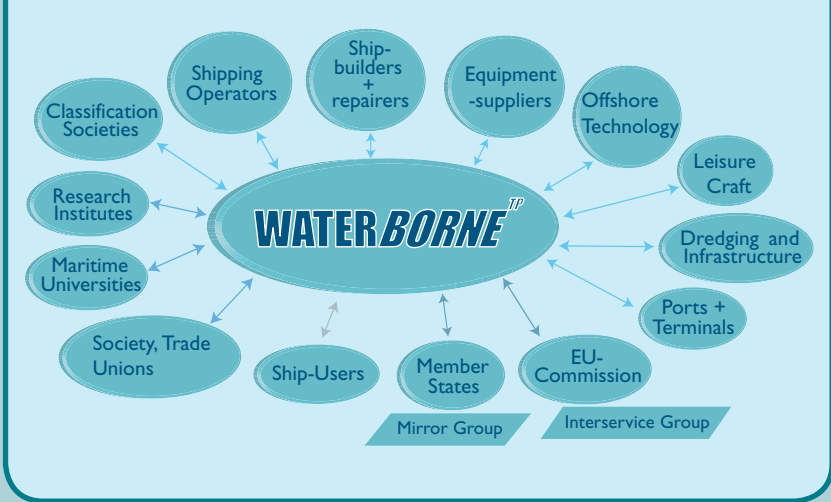

What is the expected impact of the implementation of the SRA of the Waterborne TP in 2020? Its' outcomes provide the means by which Europe will retain the foremost positions in shipping, the offshore industry, ports, including terminals and berths, dredging, shipbuilding, marine equipment, naval, inland shipping, yachting, fisheries and the maritime services sectors. Given the global growth opportunities in these key sectors, this means that the turnover and value added by the European maritime cluster will probably increase by 50 percent (in real terms) during the time horizon of the WSRA.

Maritime markets have shown strong global growth and are expected to grow further in the coming decades, which creates opportunities for European

industries. European engineering companies are world leading in terms of market share, turnover and innovative technologies. There is a strong causal relationship between these factors: and a continuous high-level of RD&I expenditure. The strong European position in industries such as offshore engineering cannot be maintained without a comprehensive RD&I strategy. Seizing the opportunities in global maritime markets in the short and medium term requires a strong emphasis on RD&I.

The WSRA is a means to realise a common vision within Europe, and at the same time create a sense of urgency within European industry, member states and the European Commission to join forces. The Waterborne TP is the permanent network organisation to facilitate this process in co-operation with the efforts of national platforms. Structural increase in RD&I expenditure by the industry should be supported by the member states and the EU Commission. The maritime cluster should be recognised in national R&D plans and European Framework Programmes as a separate entity with dedicated and earmarked funding. The WSRA has been primarily compiled to address the market and society challenges for the waterborne sector, not to satisfy political expectations. However, it supports by its nature many aspects of major policy lines and initiatives of the EU Commission, such as safety, security and sustainability in transport, and avoiding traffic congestions by modal shift.

This document provides a platform for a detailed implementation plan. The intention of the WSRA is to summarize and introduce to the executive level the numerous RD&I challenges. The acknowledgement of the importance of continued and enlarged RD&I efforts in the Waterborne sector is essential for European society and the competitiveness of the European maritime industry, as well as to contribute to the mobilisation and effective use of the necessary resources and funding.

## 1.2 Delivering the Waterborne Strategic Research Agenda

Individual member states have to increase the perception of themselves as part of a single identity that is Europe. This is also reflected across the Waterborne sectors. However, if one looks at a higher level, then it is self-evident that the large, complex, but often fragmented, European Maritime Cluster is the most complete and advanced in the world. The WSRA will help strengthen this European identity, as well as provide initiatives to create and reinforce European maritime cluster networks. The European Maritime Policy initiative by President Barroso and Commissioner Borg, will also form an important stimulus in strengthening the unity and identity of the European maritime cluster.

Implementing the SRA will require a minimum level of industry/research networks across Europe. This will support thorough dissemination of research and development results to the business units and accelerate practical implementation in daily life. This can only be achieved if sufficient funds are available to organize these networks and maintain their dynamics. The WSRA can only be implemented successfully if the coordination tasks for organising the maritime networks are supported through public funding.

There are various ways to assess the necessary level of funding for the WSRA implementation activities. An approximate cost can be based on the causal relationship between turnover and RD&I expenditure. The turnover of the European maritime cluster is in the range of €200 bn. The private RD&I expenditures, as a percentage of turnover (RD&I quote), varies between

sectors and countries. Recent work by the European maritime industries points to an RD&I quote of 10 percent. An estimated 1 to 2 percent is spent on the “R” (Research). In the offshore industry this percentage is much higher, as well as in the marine equipment sector and the naval sector. Other sectors may have lower percentages of “R” expenditure.

If one assumes an average private research spending of 1.5 percent of the turnover of the entire maritime cluster, then the current level of maritime related research within Europe is €3 bn (1.5 % of €200 bn). The industry will have to maintain at least this level of private expenditure in the future. In order to create the European maritime future, as outlined in the Waterborne TP Vision 2020 document and the WSRA, an extra effort will have to be supported by public funding. A conservative estimate is an increase of 10 to 15 percent, or €300 - €450 million per annum.



(From left to right) P. Boissier, CESA President • Dr. J. Potočník, Commissioner Science and Research  
 Prof. J. Buzek, MEP, former Prime Minister of Poland • G. Hamers, EMEC President

The aim of the Waterborne TP is not only to create this common vision of the future, but also to be recognized within the European Framework Programs as an integral whole. The world leading position of the European maritime cluster, with its' current level of RD&I expenditure as well as its' future needs, warrants such a position and recognition.

## 2. Key Priorities for Research, Development and Innovation

### 2.1 Safe, Sustainable and Efficient Waterborne Operations

Waterborne transport is the most sustainable transport mode from the economic and environmental points of view. In recent years there has been a lot of work done to reduce accident rates and consequences in waterborne transport and operations. The effect on some vessel types has been stunning; for example, bulk carrier losses have fallen to a third of the level they were in 1990. In tanker shipping the average number of large oil spills (>700 tons) during the 1970s was 3 times that during the 1990s. This was approximately 162,000 tons in 1992 and reduced to 79,000 tons in 1996, 12,000 tons in 2000 and 15,000 tons in 2004. This is against an increase by some 40% in total ocean transport of which 45% was oil and oil products.

The challenge for the marine industries is to sustain this achievement with a massive increase in waterborne transport. This is driven by ever-increasing globalisation, increasing population demand for energy and food, shifting trade patterns and the environmental need to move freight from roads to rail and water in Europe. Waterborne industries need to enable this increase, by ensuring that continuous and cost effective improvements are made in competitiveness, as well as reducing risk and keeping the environmental footprint of waterborne transport and operations to a minimum.

It is also important to continue using the principles so effectively applied to safety, for example “As Low As Reasonably Practicable”, and the “Implied Cost of Averting a Fatality”, to the environmental risk aspects of production,

operation and decommissioning activities. European society demands that all industries shoulder their responsibilities in the important environmental impact debate and that they work towards a greener, more sustainable future. Work on the low emission technologies in the shipping world, could eventually lead to the “zero emission” vessel, as and when technologies become available. Any developments however, must take into account the efficiency of the transport chain as well as the economic consequences for European industry. European companies should operate in a regulatory and financial framework that supports their international competitiveness.

RD&I priority areas have been identified for **Safe, Sustainable and Efficient Waterborne Operations** and are described hereafter.



## 2.1.1 Implementing Goal Based / Risk Based Frameworks for Cost Efficient Safety

Research is needed into the underlying frameworks of risk based design, operation and regulation. At present there is much debate about the structure, interactions and even the correct terminology of the elements of a goal based / risk based framework, as initiated at the IMO. Europe must lead the way forward in the search for international agreement in these areas through the use of reasoned argument supported by high quality research.

The potential benefits for waterborne industries of successfully agreeing an internationally accepted framework for risk based design, operation and regulation is staggering. It will free the industries' professionals to push the design envelope and allow them to produce cost effective and functionally superior products enabling Europe to remain a world leader.

### 2.1.1.1 Implementing Risk Based Regulation and Approval

Research efforts are needed to support the establishment of an internationally agreed risk-based regulatory framework including appropriate risk acceptance criteria at the top level. Effort should also be put into reducing the cost and improving the quality of the risk based approval to encourage wider application. Educating the regulator and avoiding non-uniform interpretations are the main challenges. On the other hand internationally agreed risk acceptance criteria should also be exploited to establish modern and efficient prescriptive and risk-based rules for standard designs. The European Commission funded Integrated Project SAFEDOR (FP6) for maritime transport has made a good start in this area but more effort is needed in the future, in particular related to the operation of risk-based designed and approved ships.

To help researchers advance risk based regulation and approval, effort should be given to the creation of databases for the compulsory recording of waterborne accidents. This will allow sufficient analysis to be conducted and to feedback from accidents into the risk analysis process. This task is not to supply historical data for risk analysis but to better inform the experts taking decisions regarding safety regulation by giving them a single database of accident reports to supplement their personal knowledge. The European Commission funded project CREATING for inland navigation, recently started work in this field. This is an essential and important first step towards global understanding and agreement.



### 2.1.1.2 Implementing Risk Based Design

Further research needs to be conducted into the development, and integration of risk based design tools and methodologies into existing design processes. These tools should be accompanied by strategies to collect reliability data for equipment found on vessels, as well as strategies to verify and benchmark probabilistic design tools. Research and development projects should be conducted into how to best exploit risk based design tools and methodologies. These projects should also produce designs, systems and equipment for the next generation of products for each of the waterborne sectors as case studies to demonstrate the progress made within the projects.

## 2.1.2 The “Zero Accidents” Target

The “zero accidents” target is a continuation of the excellent work done in Europe that has made shipping, arguably, the safest form of transportation available. Risk is the product of the probability of an event happening and the consequence of that event. This target aims to reduce the risks related to waterborne transport and operations by continuously aiming to reduce the probability of an accident occurring.

### 2.1.2.1 Improving Vessel Usability and Maintainability

Research and development need to be conducted on the usability of vessels, their equipment and the ship / port interface. Advanced cargo handling and lashing equipment may be developed to optimise performance and challenges of the future. Another dimension contributing to the “zero accidents” target is related to high quality maintenance of vessels, which may require innovative methods, systems and technologies addressing the safety performance of vessels during their lifetime.

An important element in ship design is the man / machine interface during the operation of the ship. Vessels built or operated in Europe may need to use intelligent bridge design. This will enable the crew and shore bases to have full situational awareness, performance monitoring and decision support based on the actual condition of vessel, cargo, , waterway, sea and weather. This can be enhanced by implementation of evolving technologies such as automation enabled by smart sensing and intelligent control systems. These technologies may lead to different manning situations on board and optimise ship’s performance.

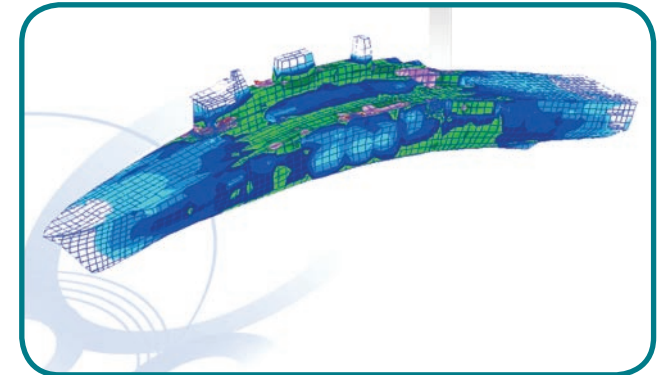



### 2.1.2.2 New Systems and Procedures for Safe Waterborne Operations.

The ever-increasing demand for maritime transport may lead to more and larger ships in European waters sea and inland ports, as well as terminals and berths. Research and development is needed to assess these developments, the reliability of infrastructure and the possible need for new systems and procedures from shore. Ultra large passenger ships will need advanced systems and procedures to support safe operation and evacuation.



Increasing European and International safety requirements often necessitate the implementation of redundancy of vital systems, e.g. propulsion or manoeuvring systems. Cost effective fail-safe manoeuvring and propulsion systems will be needed to ensure the operability of vessels under all circumstances. However the benefit of redundancy is not always obvious. Therefore research is needed to model or demonstrate the benefit of ships systems redundancy with an increase in the economic efficiency of vessel operation. For example, a more flexible arrangement of the vital vessel systems could enlarge the potential payload capacity and simultaneously significantly reduce the risk of a vessel loss

### 2.1.2.3 Enhanced Vessel Operations under Severe Conditions

An important priority area to achieve “zero accidents” is to enhance the survivability of ships. International regulations already include the challenges and loads caused by the changing environment and by harsh weather conditions. New insights into, for instance, freak waves or hurricane force storms may lead to the need for even better designed ships and off-shore installations. Robust and safe vessel, equipment and system designs will be required that can operate under extreme working conditions, for example supporting offshore exploration in deep sea and in arctic environment. Continued research must be conducted to ensure that the vessels of tomorrow and their cargos and passengers can withstand the rigours of the natural world.



## 2.1.3 The “Crashworthy” Vessel

The “crashworthy” vessel target focuses on the consequences side of risk. It is inevitable that some accidents will always occur. This stream of research and development aims to create vessels that, once an accident has occurred, will perform the vital functions required to save lives and minimise environmental impact.

### 2.1.3.1 Collision and Grounding Scenario Research

Realistic collision and grounding statistics and scenarios are difficult to establish due to poor access to data. The support of accurate and compulsory reporting of accidents by means of research and modern technology (e.g. black boxes and data logging from traffic control stations) should be introduced to vessels operating in European waters or operated by European companies. The goal is that such reports would require only a minimum in crew efforts. It would help designers to more clearly understand the accidents their products are involved in, for example collision or grounding, and allow designs to be tailored to cope with realistic accident scenarios. (Incident investigation is to be enhanced by the proposed EU Directive on the investigation of accidents in the maritime industry sector.)

### 2.1.3.2 Failure Mechanisms Research and Modelling

Once the industry has a clear picture of the type and frequency of accidents that may occur, risk based design standards can be used to define requirements for further development of accident modelling. This could include further research into the failure mechanisms of the vessel’s systems, for example the hull structure or cargo loss modelling. Existing theoretical structural models are only of very limited use today due to excessive computational efforts needed. They would need to be developed to provide practical prediction of material fracture in vessel structures under crash conditions. This modelling will then allow designers to examine how their design will perform in an emergency situation.

Prediction of accident probability and consequences will also help society and governments to prepare for emergencies. This will ensure minimum impact for the wider community by allowing planning in areas such as coastline shoreline pollution control.

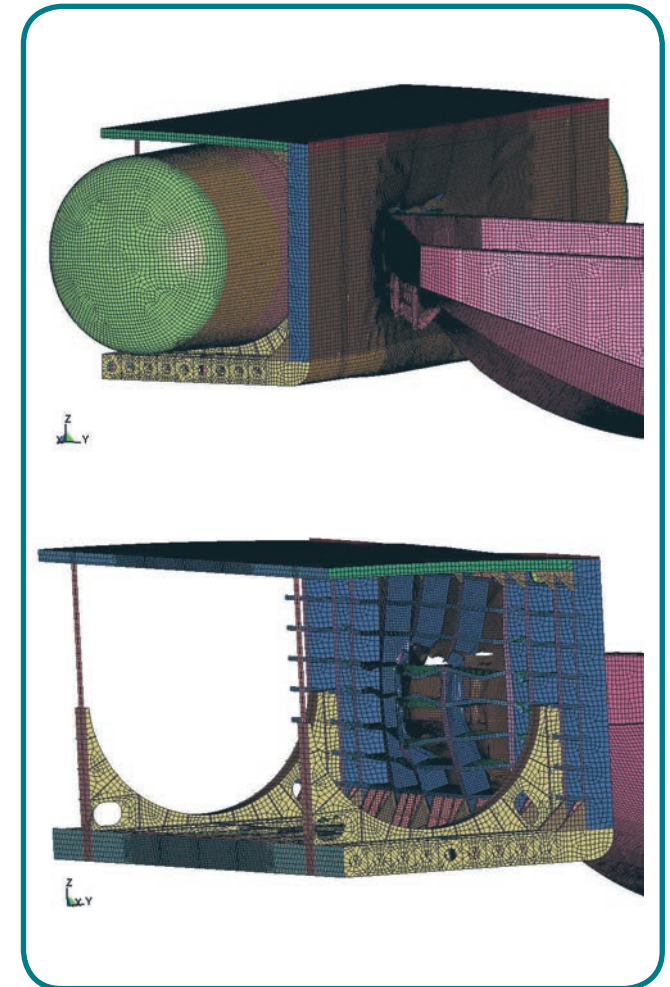

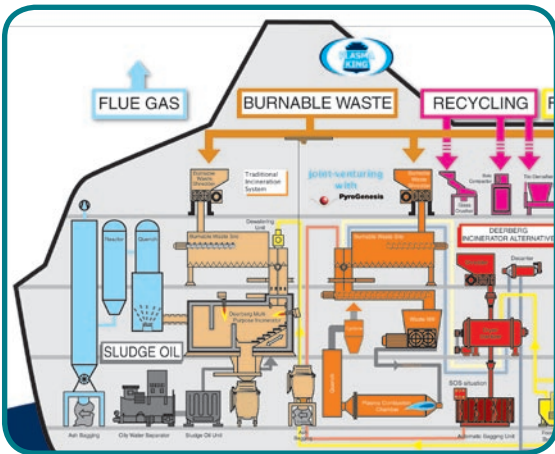
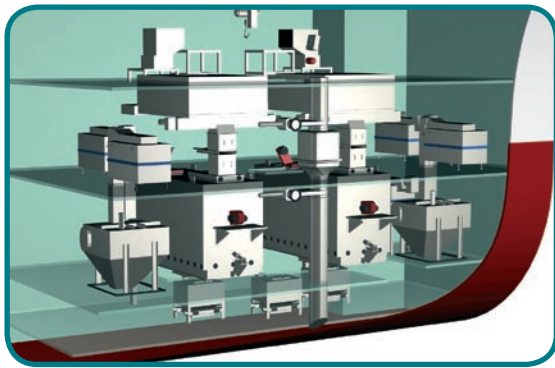
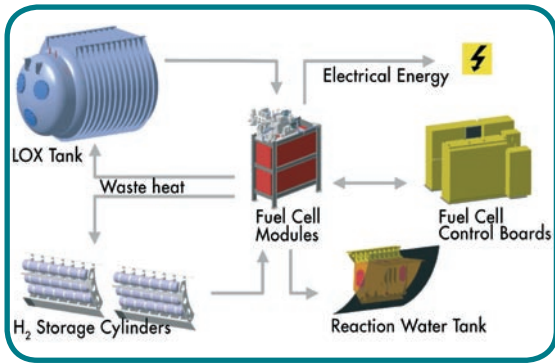

## 2.1.4 “Low Emission” Vessels and Waterborne Activities

Shipping and offshore operations are already very “green”. By several measures shipping is the most sustainable form of mass transportation available. However, due to the massive increase of ships and recreational craft, there is the challenge to keep the environmental footprint of waterborne operations within acceptable limits.

There is a need to look into all types of emissions from waterborne activities, ranging from exhaust gases, oil / ballast water pollution and waste treatment, to noise caused by recreational motor boats and wash from high speed craft. We have a responsibility to those around us. The waterborne industries must take this onboard to minimise the effect of their activities on their neighbours and the environment they live in

### 2.1.4.1 Minimising Airborne Emissions

When comparing emissions, of one ton of a cargo transported over one kilometre on a fully laden vehicle, ships produce only a fraction of airborne emissions compared to other forms of transportation. However, considering the overall increase of population and mobility as well as the increase of industrial/transport activities, every sector has to minimise its contribution. Larger ships are frequently dependent on very poor quality fuel, e.g. with a high sulphur content, that has a negative impact on emissions.

Airborne emissions will be minimised by using smaller quantities of new cleaner fuels and capturing harmful emissions. The main areas of research to minimise fuel consumption will be: propulsor/hull design integration to reduce drag and improved on board power generation efficiency and management. Improved fuel treatment and prime mover combustion performance, and better scrubbing of exhaust gases will ensure that only the minimum levels of harmful gases are released in to the atmosphere. Research in this area needs to address the current lack of adequate measuring devices of air pollutants. Simple and robust on board monitoring systems will help optimise the overall performance of engines and their emissions. For longer-term progress in this area, continued research should be completed into novel forms of power generation such as, but not limited to, LNG fuelled systems and fuel cell technology.

### 2.1.4.2 Cost Effective Waste Management and Ballast Water Treatment

Land based sources are still the largest polluter of our European waters. Nevertheless, all parties within the maritime industry need to reduce their negative contribution to the marine environment. Marine litter, anti-fouling paints, operational discharges and the transfer of alien aquatic species through ballast water are a concern of the maritime industry. Improved technologies and systems for on board waste management and effluent-/ballast water treatment are essential areas of research and development. They must be cost effective, simple and reliable to reduce the threshold of worldwide application on board. Marinisation of land based technologies need to be investigated. On board waste management needs to be treated holistically as an integrated system to minimise emissions. In the longer term research is needed into the costs and benefits of ballast free ships.

### 2.1.4.3 Minimising Wash, Noise and Vibration

Wash effects, in particular from high-speed craft, lead to the erosion and damage of shorelines and estuaries. There are sometimes serious effects on other water users. This is an important reason for the lack of acceptance for new waterborne coastal and inland transport projects. This illustrates the need to continue appropriate research and development efforts to reduce wash and its effects.

Noise of operations on the water, in particular those of recreational craft, or in ports, have wider impact on public acceptability. Strategies and technologies for the minimisation of noise due to waterborne operations have to be the subject of continued RD&I efforts. Vibration on board vessels is a cause for passenger and crew discomfort and may also lead to safety related fatigue phenomena. This is important in the context of the implementation of new materials, hull and propulsion concepts. It is necessary to understand the related vibration characteristics to be able to develop low noise and vibration solutions.

### 2.1.4.4 “Life Cycle Minimum Emissions” and Environmental Protection

Emissions should be minimised during the entire life cycle of a vessel and also in emergency situations. Research should be conducted into modelling and complete life cycle environmental impact assessments of infrastructure (such as port and dredging activities) and vessels. This will help designers to include cost efficient, active and passive mitigation in their designs, to ensure the minimum impact on the wider world.

However, accidents will still happen and it is essential that the technology exists to identify and combat emissions such as oil or other harmful substances, as and when they occur. Further research needs to be conducted into the modelling of emissions and the resultant spread of pollution. Designers must consider during the concept phase, how their products will perform during disasters. This is a particular challenge for the offshore industry as it moves into deeper waters in the search for new energy resources. Emphasis must be given to development of pollution combat equipment and vessels, which can be operated under rough weather and sea conditions and would contribute to the necessary emergency preparedness of coastal states, in cases of oil and harmful and noxious substances pollution.



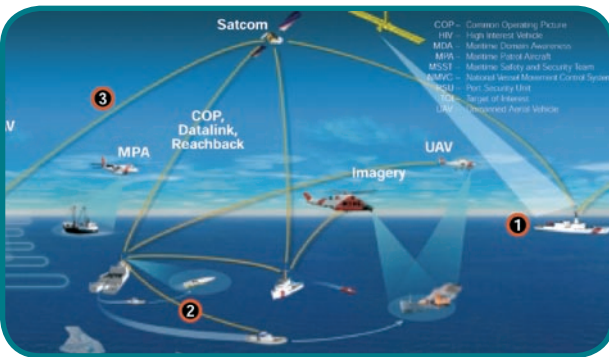

## 2.1.5 Enhanced Waterborne Security

Security research has become more important with the increased asymmetrical threats of terrorism and piracy. Individuals or small teams can today command the means to hijack, destroy, or block large systems. Security is becoming far more important and European society must understand that it affects European interests worldwide, as well as in European ports, coastal and inland waterways. Designers and operators should continue to research ways of limiting the exposure to the threat. The waterborne industry must also address the issues of drug smuggling and people trafficking. Port and Cargo security is a prerequisite for modern and integrated transport chain.

### 2.1.5.1 Monitoring and Data Logging

Europe must continue to develop monitoring, data gathering and management systems to combat the misuse of waterborne transport. This includes the development of international standards for practicable cargo inspection strategies and automatic tracking of goods to ensure they cannot be tampered with prior to or during transportation.

### 2.1.5.2 Simulation Support and Identification of Vulnerability Issues

Simulation models should be researched to analyse the sensitivity of the waterborne transport chain to piracy, terrorists, smuggling and stowaways. The research should assess not only personal safety, but also the potential economic impact on shipping operations and on society at large. This will serve to identify critical points in the waterborne network and allow for protection and mitigation should a threat materialize.

### 2.1.5.3 Development of Efficient and Economically Viable Security Strategies Equipment and Specialised Vessels

The best prevention strategy can minimise the risk of terrorist or pirate attacks, but can never exclude it totally. Ships and infrastructure; e.g. large cruise ships and ferries, oil and gas terminals, VLCCs and gas carriers may become potential disaster zones, if no appropriate responses to such attacks are developed and implemented. Research and development efforts must be spent on crisis management strategies. This research should ensure that there are sufficient plans in place in all areas of the waterborne network to deal with an attack. It should also provide operators and authorities with integrated data management systems that allow for the monitoring of incidents, and improved decision support systems in order to facilitate the best possible response to any situation. Special attention should be given to the development of equipment and vessels for frequent operation under rough weather and scarce visibility to combat the risk of terrorist and pirate attacks.

## 2.2 A Competitive European Maritime Industry

The maritime industry embraces deep sea, short sea and inland transportation of goods and people, ship building and ship repair, ports infrastructures, marine equipment, plus off-shore structures and operations as well as recreational craft. Such a diverse range of activities demands an equally diverse range of custom and series designs, vessels, support services and infrastructures. European companies belong to the world leaders in all fields of the maritime industry and waterborne operations. However, constantly changing market, society and environmental conditions create new opportunities and new challenges. The European maritime industry, based in an area of wealth and high social and environment protection standards, must address these challenges by means of technological and commercial research, development and innovation to maintain leadership and competitiveness.

Waterborne RD&I is the key to European competitiveness and covers parallel development of the supply chains, equipment and materials, manufacturing and support infrastructure. It deals with all vessel types from high volume and specialised cargo vessels, large cruise ships and ferries through special service supply ships, ice breakers, tugs and dredgers, research and coast guard vessels to super yachts, sail and power boats.

The economic impact of the maritime industry cannot be overstated. More than 3 million people work directly in the European waterborne sector and generate a turnover of about

€200 billion with a value added totalling about €100 billion. This represents more than 1% of the EU's GDP<sup>1</sup>. Maritime transport continues to grow at twice the rate of global GDP, with between 80 to 90% of all goods imported and exported by Europe being transported by sea. Within the EU more than 40% of goods are carried by water.

High quality, efficient vessels and waterborne systems mean cost effective and environmentally sustainable transport, especially where integration with other transport modes is optimised. On average, the external cost of waterborne transport is less than 1/5 of the cost of road transport. A shift of larger transport quantities from road to waterborne transport could save hundreds of million € in the external costs of transport<sup>2</sup>. This modal shift will be enabled by integrated vessel and cargo handling system designs, focused on the cargo, to deliver rapid logistics handling from ship to shore.

By its very nature, the sector is already global in its manufacturing and operations. The major players understand the worldwide differences in regulatory environments and in labour and social conditions. Given the overarching need for a level playing field, the industry's competitiveness strategy is based on high productivity, the superior performance of its innovative products and services, and an ongoing commitment to developing and implementing new knowledge.



## 1 Design Innovation

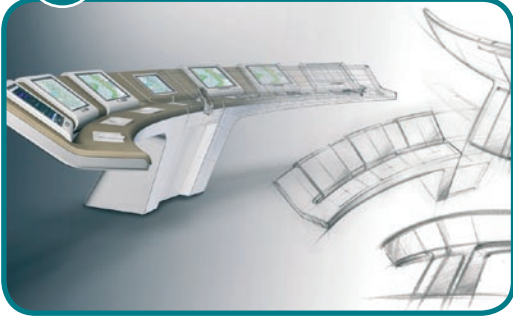

## 2 Efficient Production

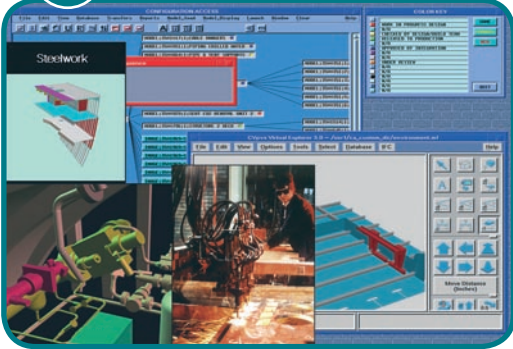

## 3 Effective Operations



To maintain global leadership and a thriving, competitive and economically effective maritime industry, three key challenges have been identified:

1) Design Innovation, 2) Efficient Production, 3) Effective Operations

### 2.2.1 Innovative Vessels and Floating Structures

The commercial and physical environment in which the maritime industry operates is changing significantly. The volume of goods is growing rapidly; more specialised cargoes need to be transported over greater distances; oil prices are rising and customer expectations are becoming more sophisticated. Enhanced reliability is also expected, but global competition is becoming more severe and more vessels are exposed to extreme weather conditions. These multi faceted challenges require the design, development, manufacture and operation of innovative vessels and ship systems, optimised for the changing conditions, as well as appropriate transport and operation concepts.

#### 2.2.1.1 Life Cycle Philosophy

The design of new, competitive and cost effective vessels and equipment needs to take full account of the complete life cycle from initial design through production, operation and end of life disposal. This approach will ensure that innovative new vessels are optimised to deliver maximum life cycle value, to minimise economic risks and to reduce the cost and risk of operation, ownership and disposal. Life Cycle strategies proposed today are often incompatible with the way shipping and transport strategies are formulated and carried out in reality. It is therefore essential to integrate Life Cycle research into real life industrial applications, taking into account the true business dynamics, e.g. the sale and re-sale of ships, and eventual disposal.

#### 2.2.1.2 New Vessels for Changing and New Markets

The development of new types of vessels will be required to exploit changing and emerging markets and to satisfy increasing customer expectations. In the energy domain, the EIA<sup>3</sup> estimates that Oil and Gas will continue to dominate the world energy scene, with global oil demand estimated to grow by more than 50% through to 2030. Increasingly, our energy future will be contingent on bringing more oil and gas to world markets in an even more globalised manner to meet rising import needs across regions. As existing oil basins mature, there is a need to explore elsewhere over large areas, in harsher conditions (deeper waters, arctic areas...etc) with deeper, more complex geology. It is forecast that oil production from deepwater fields could triple by 2010 to about 9 million barrels a day<sup>4</sup>.

<sup>3</sup> International Energy Agency

<sup>4</sup> Saudi Arabia produced an average 10 million bbl/day in 2004

In order to exploit these reserves, new vessels, ship systems and floating offshore structures will be needed. They will support ultra deep offshore operations, or operate in extreme environmental conditions, such as in Arctic and Antarctic areas where ice and high winds and seas will be encountered. Natural gas demand is expected to almost double, with LNG growing five fold. The world LNG shipping fleet will need to more than treble in size in the next 15 years. The consequences for ports' infrastructures are huge.

Technology is the key to ensuring that the necessary floating structures and vessels (LNG carriers, services vessels...etc) are efficient in an increasingly complex supply chain. New ways of coping with higher volumes of both specialised and general cargo for short sea and inland waterway operations is essential to match society's expectations of a modal shift in European transport. This will require completely new innovative vessel types and systems. The new vessel designs require to be integrated with appropriate improved shore side facilities to minimise cargo-handling costs and turnaround times and thus deliver very competitive overall operating costs.

### 2.2.1.3 Design Innovation and Systems Optimisation

The European maritime industry is a world leader in the design and build of cruise ships and ferries, specialised cargo vessels, offshore service, fishing, research and naval vessels as well as recreational craft. In order to exploit this lead, designs will need to undergo continuous and rapid evolution to ensure that, for example, the demand for very large cruise and container ships can be met economically. The expectations of recreational craft users are also becoming increasingly sophisticated, particularly in the areas of comfort, through life cost, ease of operation and safety. All of these expectations will need to be satisfied.

A competitive response to increasingly demanding regulatory regimes will require the development of vessels as optimised systems. The emerging philosophy of Goal Based/Risk Based Design and Approval is expected to contribute to strengthen competitive advantages for innovative designers. Research is required to investigate and improve the positive impact of new modern materials and better production methods on the strength, fatigue and safety properties of vessels and to take advantage of the optimisation of future designs. Innovation must cover all areas of vessel design, including the development of new strategies to simplify robust vessel and system design, vessel power optimisation and a higher degree of automation and decision support for greater vessel autonomy.



## 1 The energy efficient ship



Three critical technology areas have been identified for marine equipment: 1) The energy efficient ship, 2) Intelligent automation and navigation systems, and information management, 3) Ship/shore interface design and logistic chain integration

## 2.2.2 Innovative Marine Equipment and Systems

### 2.2.2.1 Power Generation

Today's oil based propulsion systems will become increasingly exposed to future fuel oil shortages, rising fuel prices and the need for minimal environmental impact. New energy sources and propulsion methods will be required to meet this challenge. Prime mover development will have to continue with the increased use of energy recovery systems and the requirement for high performance materials. LNG will play an important role as an alternative fuel, in the medium term for gas fuelled combustion motors, and in the medium to long term for large scale fuel cells. Diesel reformation technology will be required for the long-term widespread applications of fuel cells.

### 2.2.2.2 Propulsion Efficiency

Maximum efficiency in every part of the propulsion system will be the key competitive advantage to achieve economic and environmental targets. Advanced design techniques and materials applied to existing technology and a range of new propulsion technologies are required to achieve this. Large area (paddle wheel, 'whale tail' or bio mechanical) propulsors offer the potential for major improvements in propulsion efficiency. The designs for new propulsion systems need to be developed and optimised into new hull forms with integrated design tools.

### 2.2.2.3 Electric Propulsion

Electric propulsion can offer new propulsion system configurations providing increased ship design flexibility, with lower build and operating costs. Electric propulsion development requires reductions in the number, cost, size and weight of the electrical equipments; alternators, transformers, frequency converters, generators and electric motors. High-speed drives and generators offer low weight and size reduction. New permanent magnet and super-conducting technology will enable very efficient generators and new rim driven motors for propulsors and thrusters. Increasing demand for electrical systems will be matched by the need to minimise the power consumption, and maximise reliability and availability through innovative self-managing networks.

## 2 Intelligent automation and navigation systems, and information management.



## 3 Ship/shore interface design and logistic chain integration.



#### 2.2.2.4 Automation, Control and Navigation

Next generation automation, navigation and control systems on-board commercial vessels need to be substantially improved to reduce the costs of hardware, installation, commissioning and maintenance by 20% to 30%. The key technology is distributed control systems, where one module can be equipped, tested and set into operation on its own and the completed modules can be commissioned in a few hours.

#### 2.2.2.5 Intelligent Data Management

Greater systems sophistication and traffic densities will require higher degrees of automation and decision support in all areas of vessel operation including navigation, communication, pilotage, docking, collision avoidance and communications. Future navigation systems will become increasingly proactive and interlinked with shore based logistics management systems, for example port scheduling. They will take external data about weather systems and traffic patterns and integrate this with information on ocean currents and tides, fairway conditions and lock status, to set an optimum routing that both minimises operating costs and maximises throughput in our ports. A key enabling technology is available through the EU sponsored Galileo satellite navigation system.

#### 2.2.2.6 Cargo Handling Systems

A major challenge in reducing the cost and time of marine transport compared to road and rail is cargo handling. Innovative approaches to the design of vessels as a logistic chain component need to start with the cargo and the most effective way to move it from one transport mode to another. The design of the vessel needs to simplify its mooring, loading and unloading and the use of the latest automated shore side facilities. State of the art automated and robotic systems, with computerised process management are required to meet this challenge. This has to be combined with strategic infrastructure planning.

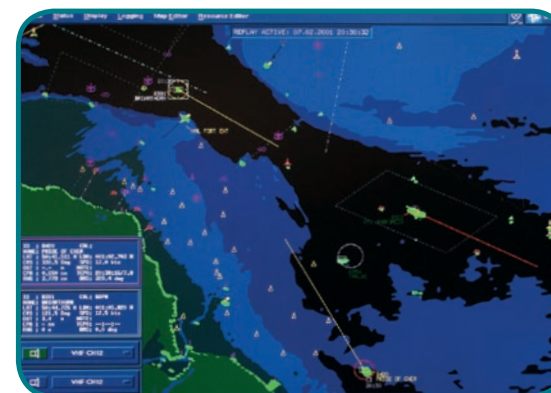

## 2.2.3 Tools for Accelerated Innovation

Accelerated innovation is critical for the success of the future competitive position of the European maritime industry. Rapid innovation is based on the intelligent collection, assessment and application of new knowledge. Leaner management systems and tools are required in order to facilitate this rapid practical application of new knowledge. We must develop more competitive, sophisticated and robust vessels, equipment and systems, faster than other competitors.

### 2.2.3.1 Tools for Design and Analysis

Advanced Design and Knowledge Management Tools will have to be developed which enable a substantial reduction in lead-time. In particular, this must enable the easy use of previous design data and modules, supporting concurrent design and offering comprehensive interfaces to procurement and production planning.

Improved tools and software for design, analysis and modelling of advanced structures, hydrodynamics and engineering systems are required to support the design process and to enable vessel optimisation, in particular in the context of the Goal Based/Risk Based Design philosophy.



### 2.2.3.2 Simulation Software for Process Acceleration and Minimising Risk

Simulation tools have already proven their potential for reducing lead-time and risk, and this approach must be intensified. Reliable tools for performance simulations of the transport chain, vessel and systems, as well as for production processes and methods, have to be developed to support concurrent design and optimised solutions.

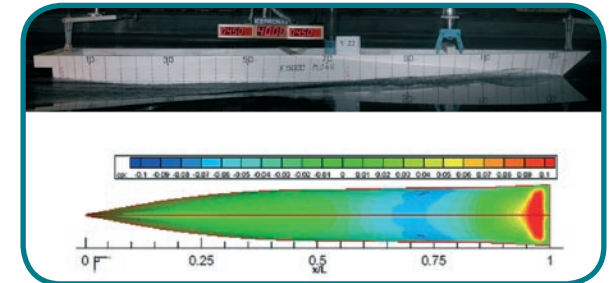

### 2.2.3.3 Product Model and Inter-System Data Communication

A main obstacle for distributed production and supply chain responsiveness is the lack of compatibility of product data models and CAD/CAM/CIM data representations. Considerable RD&I effort will be applied to enable better communication between different databases, software modules and company ERP systems. The development of a standardised product model data representation is an important target.

Software tools to support the definition of modules and module interfaces are required in ship and yacht building, both for the individual modules and for the overall planning of the vessel. This must be integrated in standard design tools and made available to designers for daily use.

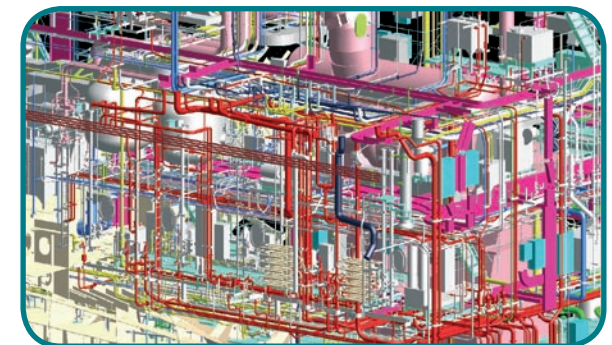

## 2.2.4 Next Generation Production Processes

Productivity, flexibility and responsiveness in manufacture are absolute key factors for competitiveness in a region with high labour costs. European producers must command the world's most effective production processes by leading edge "home yard" production methods, as well as intelligent supplier network management systems and tools. The winning strategy is to offer clients more customisation of vessels whilst providing a shorter time to market for customised or entirely new concepts. More RD&I efforts will have to be spent to organize ship production facilities and resources to support this strategy. RD&I activities also need to be co-ordinated on relevant market analysis, technology forecasting, scenario methodologies, networking and the cross ferti-lization of ideas and technologies.

### 2.2.4.1 Innovative Process Management Systems

To ensure the effective and rapid implementation of innovations for vessels and offshore structures, improved and leaner management systems are required. The aim is to afford the necessary integration of all aspects of relevant knowledge facilitating effective collection, assessment, screening and integration. This will foster the rapid exchange of data between the shipyards and materials and equipment industry supply base.

### 2.2.4.2 Integration of Design and Production Planning

A key factor to reduce lead-time and a priority for RD&I effort is the integration of design and production planning software systems and databases. This must enable optimised production methods and evenly distributed value chains (outsourcing). Available production capacity information will be combined with early input from the design system, to deliver simulation feedback from production planning to design, in order to enable early changes and optimisations.

### 2.2.4.3 Modules, the Building Blocks of Future Vessels

Modularisation will enable a more effective outsourcing of complex work from the 'Assembly Yard' to specialist system and sub system suppliers. This is an important strategy for high productivity, by increasing the number of repeat operations and the use of standard or modularised components. However, the practical application of modularisation is complex and challenging and still requires fundamental research and development.

There is a lot of research and development work to be done to transfer suitable experiences from other industries, to determine the appropriate level of modularisation for different vessel types and to understand the implication for the entire production optimisation and individual methods. Management of networked production must also consider the safety of employees from different enterprises and countries working together in an assembly yard.

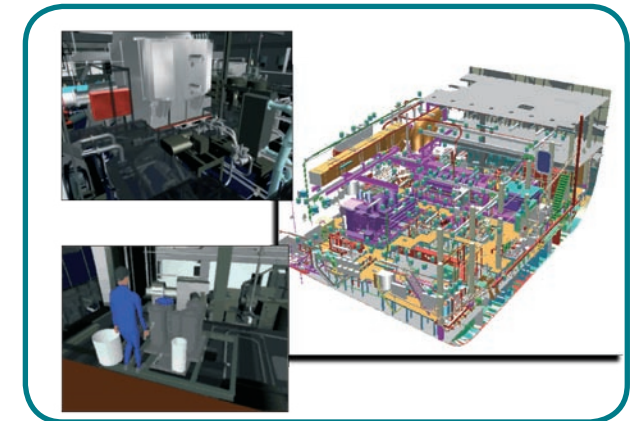

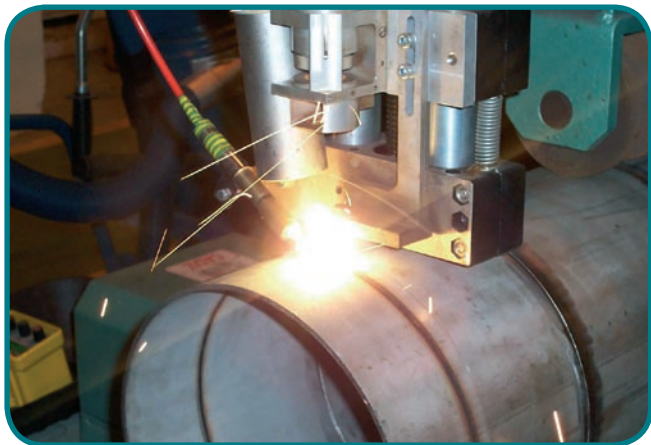

#### 2.2.4.4 New Materials and Production Methods

It is an ongoing and large RD&I task to investigate emerging new materials, structure types, technologies and production methods to determine their potential benefits for the maritime industry. Materials Technology Transfer from other industries must be utilised whenever possible.

New, more cost efficient vessels will require the development of lighter and stronger engineering materials such as advanced composites, alloys and sandwich structures. Composites could be exploited much more extensively if research to develop enhanced material properties and fire resistance is carried out. New production techniques must be developed to satisfy the demand for speed and cost efficiency and to ensure a safe, clean and efficient working environment.

The efficiency and safety of waterborne operations is crucially dependant on effective corrosion protection in the challenging marine environment. The ongoing development of advanced corrosion protection and coating systems, which do not pollute the environment, and methods for reliable and cost effective application and inspection are an important competitiveness factor.



## 2.2.5 Effective Waterborne Operations

Waterborne transport is by far the cheapest mode of transport and the only one that can cope effectively with large quantities of goods. It is a worldwide market with a long tradition of “freedom of the seas”. Today’s shipping industry is challenged by increasing demands for continuous improvements in performance, cost of operation, efficiency, safety and sustainability. These pressures result in recognised trends, such as ever larger and more complex ships putting to sea with ever smaller and less experienced crews. The industry is becoming increasingly reliant on automation and the application of proven processes placing stricter requirements on control and management systems. To meet the challenges of this future trend and to defend a competitive position several RD&I initiatives are necessary.

### 2.2.5.1 Supporting Tools for Life Cycle Cost (LCC) Planning and Minimisation

The development of holistic strategies for through life cost reduction is an important field of research. Tools for modelling LCC will have to be developed to assess and optimise the impact of improvement measures in LCC reduction, e.g. properties of the new vessel and maintenance schedules. Emphasis has to be put on designing tools and methods that are representative of the conditions of daily operations.

### 2.2.5.2 Minimisation of Energy Consumption

A prime cost factor in future scenarios is fuel consumption for propulsion, manoeuvring, cargo treatment (e.g. cooling), heating/ventilation/air-conditioning/climate (HVAC) and other vessel functions. Energy demand for functions other than propulsion is high for many vessel types (not only the cruise ships). Advanced power management systems, in combination with intelligent power generation concepts that adapt to the demand profile, will contribute to substantial cost and resource savings.

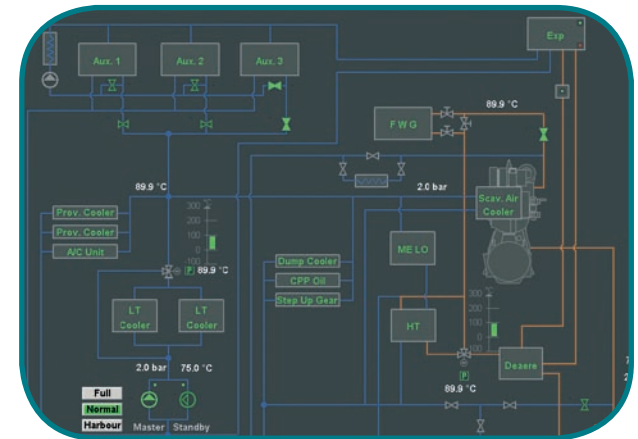
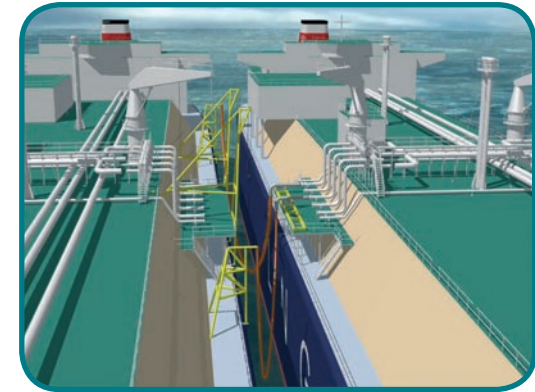



### **2.2.5.3 Intelligent Maintenance Planning and Optimisation**

Improved and optimised maintenance scheduling is a key factor for competitiveness. It will be enhanced by the further development and implementation of emerging technologies such as embedded Equipment Health Monitoring (EHM) to provide an enhanced and reliable predictive maintenance support. European leadership in the world equipment market is the platform for service business expansion. All high value equipment needs to have EHM systems embedded into the design. Equipment through life reliability models will be required to provide the prognostic capability to deliver condition-based maintenance. Development of in service performance databases and innovative intelligent pattern recognition tools will deliver robust maintenance planning information. This will maximise the availability of the ship and its asset value. It will enable ship operators to upgrade ships in service for optimum efficiency and new regulatory standards.



### **2.2.5.4 Automation and Platform Management**

New developments in process automation, computer technology, sensors, smart components and communication must be applied to the maritime industry to enable the safe and efficient operation of increasingly complex vessels with a minimum of crew. The control systems must be designed by goal based methods to achieve the objectives of economic operation, safety and environmental protection. The individual systems need to be designed to standardise hardware and software interfaces within a holistic platform management concept. The on-board decision support systems will be linked to shore based control centres for technical back up and incident management support.

## 2.2.6 Technologies for New and Extended Marine Operations

A number of completely new marine activities are beginning to emerge, particularly in the offshore wind, wave and tidal energy markets. In addition, more traditional activities such as offshore oil and gas exploration and exploitation, are pushing into deeper and more difficult environments. New vessels and systems will have to be produced to deliver and to support these activities. These include deep-sea offshore support vessels, new LNG supply lines and both floating and tethered structures for the exploitation of marine renewable energy.

### 2.2.6.1 Procedures and Support Tools

As conditions and applications become more demanding, the sophistication of the systems that support these applications also needs to increase. Working in more challenging environments can be enabled by improved dynamic positioning and mooring systems with a higher degree of automation and decision support for the human operator. Methods need to be developed to ensure that new structures can be effectively maintained and then removed for environmentally sustainable disposal at the end of their life.

### 2.2.6.2 Enhanced Sub-sea Capability

The need for ever more sophisticated mechanised support increases as it becomes necessary and more economically viable to exploit the sub-sea environment to greater and greater depths. In the next 20 years it will be a requirement to carry out routine operations at depths up to 3000m and new, remotely operated vessels (ROV) and robots will be required to enable this to take place.

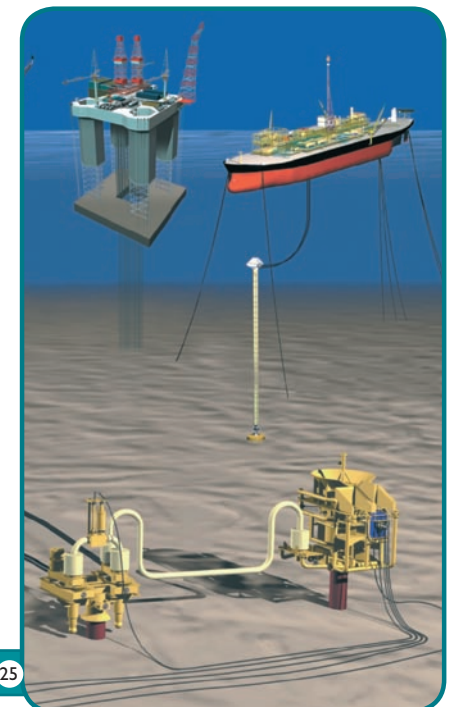
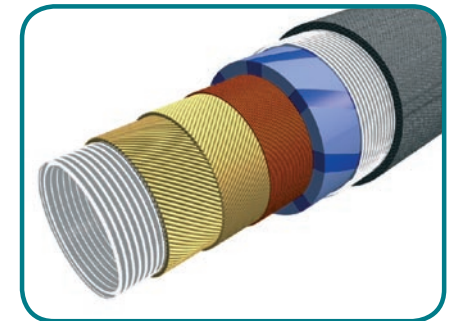
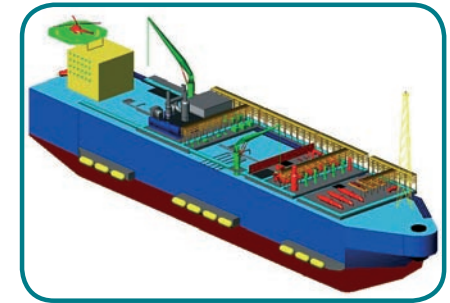

## 2.3 Manage & Facilitate Growth and Changing Trade Patterns

World population is growing rapidly, from about 6 billion in year 2000 to around 8 billion in year 2020, mainly in Asia and Latin America. The demand for food and energy is growing accordingly, e.g. in 2020 an additional demand for primary energy of at least 50% compared to today's level can be expected. The consequence will be an increased waterborne transport requirement. The changing distribution of population and industrial production, as well as the rapidly growing global co-operation and outsourcing, are adding substantial worldwide waterborne transport demands. Europe has the largest single share in global waterborne transport. Maintaining this position requires focused efforts to accommodate and safeguard the growth of trade flows and adapt rapidly to changes in global trade patterns.

Immense challenges must be faced to ensure that Europe's seaways and infrastructures remain capable of safely handling the increased number and size of ships. These infrastructures require long lead times for development to accommodate increasing trade. A modern network of seaports and inland ports must constantly evolve to provide the forecast activity increases of the order of 10% per year. Additionally, facilities for pleasure and sport boats must expand to meet the increasing public demand for waterborne leisure.

These key challenges for waterborne transport and the related maritime industries drive the RD&I agenda. In parallel, other challenges relate to protection of personal safety and the environment from the effects of strong growth in traffic intensity, vessel sizes and cargo volumes. These challenges are being addressed separately under pillar I.



## 2.3.1 Accelerated Development of New Port and Infrastructure Facilities

The development of waterborne traffic by new European policies of motorways of the sea and transfer of cargo from the road transport to inland navigation, will require the development of new ports, terminals and inland waterways. Therefore, research activities are necessary to identify efficient, economic and environmentally friendly technical solutions for building, maintaining and upgrading port and inland waterway infrastructures, as well as navigable canals. New or extended infrastructure for waterborne transport, such as ports, locks, canals etc., requires much longer lead times than the construction of the vessels themselves. There are geographical limitations in Europe due to population density, sensitive ecological areas and the possible democratic influence by concerned local citizens. This requires integrated early planning and optimisation of transport chains in order to cope with the growth phenomena and to safeguard Europe's wealth. Research can support planners, industry and society with better data, tools and methods, to accelerate decision processes and make them more transparent and acceptable. It can also help to optimise at all times the use of existing and hard to re-configure facilities.

### 2.3.1.1 Planning Tools for Optimal Logistic Chains and Hinterland Connections

Throughout Europe the road and rail transport systems are suffering ever-increasing congestion. Road systems, particularly in the vicinity of major cities, regularly suffer gridlock conditions, with serious adverse impact on business efficiency, competitiveness and international trade. Terrestrial transport systems are in crisis. A reduction in the volume of goods transported by road and rail will provide positive economic and environmental benefits. The optimisation of transport chains featuring waterborne transport, whether by sea, or inland waterway, has the potential to reduce congestion effects in road and rail transport. It must be supported by intelligent planning tools and by reactive and agile real-time scheduling systems.

The advantages enjoyed by the other surface transport modes relative to the waterborne are primarily speed and the convenience of door-to-door delivery. In this respect, rail has no significant advantage over waterborne, other than in areas remote from the sea, or a suitable waterway. The challenge therefore is for waterborne to match, or to move closer to, the advantages of road transport. Research efforts are needed to facilitate improvements to major and minor ports, enhance inland waterway capacity, develop improved container systems and cargo transfer and integrate ICT solutions and optimise modal transfer points. Research efforts are needed to facilitate improvements to major and minor ports, enhance inland waterway capacity, develop improved container systems and cargo transfer and integrate ICT solutions and optimise modal transfer points.

The know-how developed will become an exportable expertise in itself, to the direct benefit of European operators in global transport chains.



## 2.3.2 Interoperability between Modes

Intermodal transport in Europe is on the way to a second revolution. Through new cooperative partnerships, changes in behaviour and the adoption of a long term strategy, intermodal transport can eventually reach its full potential across the whole logistic chain. However, to make this happen, extensive investment is required in infrastructure, equipment and information systems in order to improve the all important transfer of loading units between the various modes of transport – rail, ship, barge and road.



### 2.3.2.1 Transfer Nodes

Intermodal transport involves the transfer of loading units from one mode of transport to another. Based on current intermodal activity, there is a potential capacity shortfall of loading units in Europe by 2015. Any real increase in intermodal transport will require a significant additional increase in transfer nodes across Europe. Increased interoperability depends upon access to sufficient transfer nodes. Research is required into the setting up of a network of transfer nodes around Europe and should encompass the merits of using both public and private sector investment.

### 2.3.2.2 IT Systems

The only way truly joined up intermodal transport can function is through the use of information technology. Open IT systems are needed to support booking, invoicing, tracking, trans-shipment and crucially to allow the user to be fully informed. This is essential to maximising interoperability between modes. Research is needed to define the most suitable IT system that can serve the needs of all the participants.

### 2.3.2.3 Systems of Transfer

Within the intermodal process, loading units are transferred from one mode to another e.g., ship to train, train to road, ship to road, road to barge. Some of these transfers are less efficient than others. This is because either the handling equipment used is not totally compatible or because the system of loading and unloading involves unnecessary re-handling of loading units. Research needs to be carried out into the most efficient transfer methods available and into when and where they should be applied. It is assumed with regard to any and all developments that the maintenance of safety standards will remain paramount.

### 2.3.2.4 Intermodality of Transport

The perception of intermodal transport is that it is difficult, complex and ineffective. Such beliefs are reflected in assumptions about the interoperability between modes. Thus, investing in infrastructure, equipment and information systems to improve interoperability will only be effective if efforts are made to increase the level of awareness amongst all those who could participate in intermodal transport. Research must be conducted into the best way to promote intermodal transport in all its aspects. Promotion includes, not only the launching of new products and services, but also the continued awareness amongst the target audiences.

In the growing demand for transport services, Intermodal transport will play an increasing role. From a logistics perspective, the most economic mode or combination of modes will always find its way. This has a few implications:

- Not all modes have the same initial framework conditions/the same chances.
- This will not automatically lead to the combination of modes that are least destructive on the environment.
- Interoperability between modes is a crucial factor to ensure 'seamless' transport and ensure a high level of efficiency (lowest possible costs, shortest timeframe).

### 2.3.2.5 High Quality and Efficient Intermodal Services

Intermodal transport requires high quality and very efficient services from all transport modes. Research goals are therefore proposed that are not only specific to a single mode, but will rather formulate research goals related to the interlinking of modes. To be competitive, intermodal transport should deliver a high quality service (seamless, fast, and reliable) and be highly efficient (low costs). 'Integrated Freight Transport Management Logistic Systems' have been examined/developed in a number of projects. The proposals in respect of Logistics research include:

- Information technology and logistics must be integrated to form the "smart supply chain", embedded in a common EU intermodal, cross-border strategy.
- IT system must control all points in the supply chain (based on harmonized information availability and automated tracking & tracing features), including terminals and trans-shipment points.



## 2.3.3 More Effective Ports and Infrastructure

It is necessary to narrow the gap in the point-to-point delivery time of waterborne transport relative to road transport. This can be achieved by various means, including minimising the distance from vessel discharge point to consumer; minimising docking time; minimising transfer time from ship to shore; minimising time to identify, select, transfer and clear individual consignments. To achieve this, several RD&I activities are important.

### 2.3.3.1 Equipment and Systems for Faster Cargo Handling

Major European ports are equipped with modern rapid cargo handling systems, but there is scope to improve these and opportunities for improvement must be regularly reviewed. However, many smaller ports and harbours are not equipped with modern and standardised handling facilities. These have to be made available cost effectively for smaller applications, to fulfil the objective of delivering waterborne goods closer to the consumer and in less time.

Research activities are necessary to identify weaknesses in the existing port systems, including inappropriate and non-standard handling facilities and to propose Europe-wide standard solutions. This must be done in conjunction with new concepts of vessels and innovative loading/unloading systems. Improvements are necessary to trans-shipment methods to reduce trans-shipment time and thus encourage greater use of short sea, coastal and inland shipping. Express, secure port network systems and procedures should be developed to facilitate more rapid and secure transit of goods throughout their entire transportation from door to door, including inter-port trans-shipment. This will reduce containers' dwell time in ports to only a few hours instead of days.

### 2.3.3.2 Automatic Operations

Appropriate and standardised automated docking systems have the potential to reduce point-to-point cargo delivery times. Any significant reduction in time will improve the competitive position of waterborne transport relative to road, but also will improve overall operational efficiency resulting in lower unit costs. This will be most significant for high value vessels such as large container ships and bulk carriers. A standardised cost-effective system should be identified and developed. The automation of marshalling areas is already a feature of a few large ports, but has yet to be widely adopted. Research is needed to determine whether automated marshalling can be safely and economically introduced to a wider spectrum of ports sizes and types.

Automated control of vessels approaching/departing port using intelligent systems and improved navigational aids could significantly help to increase efficiency and safety of ship handling. The technological aspects of such development should be investigated along with a consideration of the legal and regulatory aspects.

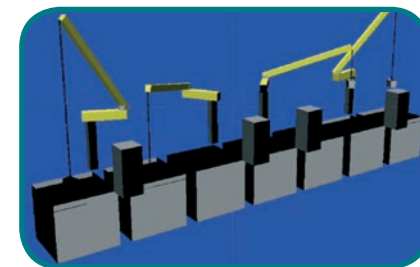
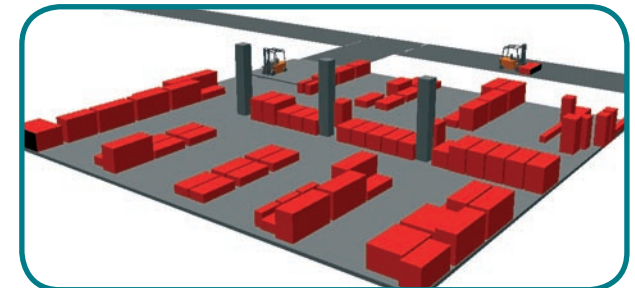

## 2.3.4 Intelligent Transportation Technologies and Integrated ICT solutions

Integrated ICT and ITS will be a key future capability. They are a European key competence demonstrated e.g. by the status of development of River Information Services (RIS). Innovation in this field is essential. It will enable more efficient planning, booking, simulation, routing and control of cargo along the different transport modes as well as providing other services supporting efficiency, safety and security.

### 2.3.4.1 Optimum Vessel Utilisation

Waterborne transport maximises its economic and environmental benefit when each vessel carries as much cargo as possible. Individual experience and manual methods dominate commercial operation of vessels. Improved control and decision-making requires introduction of a new breed of management tools to ensure the maximum utilisation of vessels at all times. Such systems could be used to predict real-time customer demand and to optimise the price and availability of products and services. The ability to analyse information, plan efficiently and provide value added services are key factors to remain competitive in the shipping business in the future.

### 2.3.4.2 Container Imbalances and Management of Empty Containers

Most and notably the main container trade lanes show serious imbalances. There is good reason to expect such imbalance to increase in Europe, due to increasing imports and reducing exports of manufactured and other unitized goods. As a result empty containers, in whatever mix of 20', 40 and specials, are piling up on one end of the trade and have to be repositioned under the shipping lines' global container management systems. This situation poses organisational problems and increasingly risks creating congestion in port terminals, inland depots and on connecting infrastructure, all leading to inefficiencies and increasing costs in the supply chain. An in depth assessment of the features, all actors involved and the large variety of influencing factors should form the basis for a holistic common approach and management systems between parties, supported by appropriate ICT solutions.

### 2.3.4.3 Simulation of Logistic Chain

To maximise the expansion and efficiency of waterborne transport it is necessary to develop user friendly programs that simulate the total point-to-point transport chain so as to quickly determine the most cost effective and rapid combination of transport modes that are available at a given, or required time.



### 2.3.4.4 Ports Network and Data Exchange

To maximise the efficiency of the real time transport opportunities and vessel utilisation it is necessary to develop a web-based system of port networking to identify and exchange vessel locations, planned routes, cargo facilities and dates and times of movement.

### 2.3.5 Understand Environmental Impact of Infrastructure Building and Dredging

The development and expansion of port capacity and hinterland connections requires appropriate consideration for the preservation of natural habitats in the surrounding areas. However, it is essential to achieve a balance between protection of natural habitat and species, social need and Europe's competitive position in the global market. Today the situation is out of balance. Excessive regulation is often conceived in isolation of many factors, wider considerations and implications and as a result is even conflicting. Though well intended, such regulation is causing an unacceptable impediment to progress. This is damaging to Europe's competitive position and will continue to cause damage until a balance is restored between progress and protection. To achieve that balance it is essential to improve understanding of the cause and effect of development activity in the marine and coastal environment. Development decisions must be based on science and knowledge, not on emotion.

To achieve a proper understanding of the impact of development, including dredging and land reclamation, relative to other causes, it is necessary to properly understand the relative scale of each. Research activities are needed to measure the level and extent of sediment suspension and dispersion caused by natural events (e.g. storms and high river flows) and by commercial fishing (including beam trawling, shellfish farming and harvesting) in the shoreline zone and on inland waterways. The effect of sediment of suspension and deposition on ecosystems and the sensitivity of wildlife, particularly birds, to new development must be investigated more closely, in cooperation and co-funding with ecologist and biological programmes. The know-how developed in this context will become an exportable expertise in itself, to the direct benefit of European operators in the global and transport chains.



### **2.3.5.1 Analysis of Regulatory Functions, Inconsistencies and Public Decision Making Processes**

In the past decade the regulatory system in Europe, usually in the form of Directives and their implementation at National level, has expanded rapidly. The objective of these various regulations is commendable: to maintain, or improve, the natural environment within which man, wildlife and flora must co-exist and to avoid damage to the natural environment and eco-systems. This is undeniably good, but only if regulation and its application is properly conceived and interpreted in a consistent way. This is not always the case. A single objection made without the support of scientific evidence may halt, or seriously hinder, the progress of new development. Restrictions should only be imposed which are clearly supported by multidisciplinary scientific results.

So that the aspirations of commerce and the concerns regarding the environment may be mutually satisfied, it is necessary to streamline and standardise the planning process and the implementation of regulations. Two essential steps are necessary to achieve this: to identify (and later eliminate) duplication and conflict between different regulations and to provide a Europe-wide system to steer projects expediently through regulations via a logical, efficient and consistent route. To achieve this, research is needed in the form of analysis and comparison of the relevant European Directives and National regulations. The output of this study should be the identification of conflict and anomalies within regulations and a step-by-step guide to the achievement of harmonious compliance with all relevant regulations in a cost effective and expedient way.

### **2.3.5.2 Marina and Leisure Facility Development**

The most critical factor limiting the further growth of the recreational craft and marine leisure industry in many countries is the lack of space to moor new craft. This is similar to the constraints on the development and expansion of port capacity. It is a result of the very stringent planning and environmental controls which make the expansion of current facilities, and the creation of new facilities increasingly difficult. This problem may be addressed in part by the proposed review of environmental legislation. However, at the same time, the recreational craft industry must develop new and innovative ways to ensure that users can access the water cost effectively.



## **3.2.6 Traffic Management Strategies**

Managing the dramatically increasing amount of traffic in European waters will require excellent ICT support systems. However, it is also essential to design such traffic management systems in a way that is 'user friendly' for all participants (especially the small ones). The systems must enable a reliable overview of the immense number and variety of waterborne traffic. They need to consider the requirement for free access to as wide a geographical area as possible at a low cost, in order to achieve an acceptable public safety culture with minimum regulation.

### **3.2.6.1 Decision Support Systems and ICT**

Efficient data models and algorithms are required for shore based traffic management systems. These must be developed, tested and implemented for large numbers of participants and high risk / dense traffic areas; as well as for port approaches and port call preparation. Man-machine interfaces will have to be improved and simple to use. Decision support systems need to be developed and tailored for land based and on-board use to minimise the potential for human error.

# 3. Implementation strategy

## 3.1 Critical Enablers

There are some important enablers that are critical to achieve the Vision 2020 goals by means of the WSRA:

### 3.1.1 Human Resources, Education and Training

The focus on knowledge intensive products and processes is a key factor for the competitiveness of all segments of the European maritime industry. The increasing complexity and volume of waterborne transport and operations, as well as the new challenges in exploring deeper and more remote areas of the oceans, requires world class individuals and a highly qualified work force. The sector must be promoted as an attractive field of employment, offering challenging career opportunities at all levels. New strategies have to be developed for higher education, training of seafarers and industry workers. This would include adaptive courses, electronic learning and simulation, “post-seafaring” career opportunities, cross industry job rotation and management development, as well as a “back to engineering” campaign. Life long learning and a sustainable work environment will retain the necessary knowledge and skills in the industry.

An important element to attract young talents at the universities will be more permanent “cluster” structures between universities, research centres and industry. This could be achieved by more industry controlled and topic focused Networks of Excellence (NoE), direct industry/institute/university co-operation, development or similar permanent initiatives. This also requires the introduction of a Europe wide competition culture in the universities, as well as the coordinated and focused use of regional and national resources, for the basic funding of universities and research institutes. This must avoid unnecessary duplication of capacity instead of creating excellence.



### 3.1.2 Defending Intellectual Property (IPR)

Nearly all inventions in the maritime field have their origin in Europe, but emerging competitors to the European maritime industry have had “free of charge” access to IP in many cases, due to a lack of an IPR culture and enforcement. It has more than a taste of irony that the diverging business interests of parts of the European maritime industry, have also fuelled the technology drain of the past decades. The WATERBORNE Technology Platform will pay special attention to this issue, building on the activities of the European Shipbuilding industry, which has included the IPR topic in its “LEADERSHIP 2015” initiative. The awareness of “European Intellectual Property” has also to be raised in the political field. We must avoid the funding of technology transfer activities with European taxpayers money, to “developing countries” that are already aggressive competitors for European industry on the world market.



### 3.1.3 Political Framework: Joint Initiatives and Level Playing Field

The WATERBORNE Technology Platform intends to contribute to a higher worldwide level of safety, sustainability and environmental friendliness of waterborne operations, implemented by the responsible international bodies and backed by the weight of the European Union.

A European dimension in collaboration efforts on RD&I activities supported by public funds requires the political will to co-operate. Practical experience shows that there is a long way to go to reach this goal. The WATERBORNE Technology Platform, in which the Member States are represented in the Mirror Group, intends to contribute to identify possible synergies in funding programs. However, the harvest of such synergies could only be successful, if all public stakeholders will synchronise and cooperate.

Waterborne transport and operations as well as the related vessel design, equipment and production businesses are global activities. RD&I efforts will lead to competitiveness if these markets have a level playing field. Regulatory initiatives that are taken by the public stakeholders impact on competitiveness. They must be considered in order to avoid creating structural disadvantages for European industry.

Free access to markets will be an important enabler for the success of the European maritime cluster. For example, European companies are world leading in the dredging sectors. However, these companies cannot benefit fully from their advanced technological positions, as some important markets such as the USA are closed to them. The European future in dredging could be stimulated by removing these invisible obstacles to market access. This applies also to other areas of the waterborne sector. Removing such obstacles should also be part of the new European Maritime Policy initiative.



## 3.2 Implementation Summary

The RD&I activities in the waterborne sector are many-fold:

- Basic Research in Universities and Research Institutes; funded by industry, national bodies or the EU
- Industrial Research and Development in Companies, Research Institutes and Universities
  - Individual company level, without public funding or with national funding support
  - Joint Industry Projects (JIPs): Cooperation between several companies and research institutes/universities, without public funding or with national funding support
  - EU funded Specific Target Research Projects (STREP) or Integrated Projects (IP): cooperation between multinational groups of enterprises and research institutes/universities
  - Implementation of Research & Development Results in commercial Prototypes and Processes

Starting RD&I activities as well as finding and financing the necessary resources, has always been, and will remain the responsibility of the individual stakeholder entities.

The WATERBORNE Technology Platform will contribute to:

- awareness of RD&I necessity in the waterborne sector
- stimulation of activities and the periodical compilation of overviews, especially in the priority themes
- definition of large scale and cross industry projects and initiatives
- inter-modal integration of transport chains, by maintaining regular contacts to the respective other transport Technology Platforms and by supporting inter-modal initiatives
- dissemination of public results and experiences

- identifications of new RD&I challenges and the periodical updating of the WSRA
- analysis of existing funding support on regional, national and EU level and the identification of possible synergies
- mobilisation of financial resources by analysing the respective financing possibilities and consulting its members
- technical and administrative assessment, evaluation and processing of EU funded projects by means of initiating a pool of independent maritime evaluators and other supporting services, at the disposal of the Commission
- exchange and technology transfer with other industries, and where advantageous and reasonable, by maintaining regular contacts to the respective Technology Platforms
- promotion of the waterborne sector as an attractive, innovative and challenging field of employment and career opportunities, to secure the HR base in the competition for the talents

These contributions will be facilitated by the organisation of temporary and permanent Working Groups within the WATERBORNE Technology Platform. These will define the initiatives and perform the necessary analysis work, with voluntary experts from industry and research community. These Working Groups will be organised and supported by a permanent secretariat.

The WATERBORNE Strategic Research Agenda defines the key priority themes for the RD&I activities in the waterborne sector for the next 15 years.

The WSRA overview will be supplemented by an implementation plan. More detailed descriptions of RD&I topics are contained in the published inputs to the WSRA. All publicly available documents are available for downloading from [www.waterborne-tp.org](http://www.waterborne-tp.org)

# Contributing Bodies

## SUPPORT GROUP

### ► Industry and Associations

The contributions were made by the following associations and various experts of their members (companies, institutes, universities, etc).

#### • **Support Group chair**

EurACS (European Association of Classification Societies)

#### • **Support Group secretariat**

CESA (Community of European Shipyards' Associations)

EMEC (European Marine Equipment Council)

EUROGIF (European Oil & Gas Innovation Forum)

EBU (European Barge Union)

ECSA (European Community of Ship-owners' Associations)

ESPO (European Sea Ports Organisation)

EUDA (European Dredging Association)

EURMIG (EU Recreational Marine Industry Group)

FEPOR (Federation of European Private Port Operators)

#### Research and Education

ECMAR (European co-operation in Maritime Research)

WEGEMT (European Assoc. of Universities in Marine Technology)

#### Society and Environment

EMF (European Metalworkers Federation)

## MIRROR GROUP

### ► Member States

#### • **Mirror Group chairman**

Netherlands, for the Ministry of Transport, Public Works and Water Management

#### • **Mirror Group secretary**

UK, for the Department of Trade and Industry

Austria, for the Ministry of Education and Science

Belgium, for the Federal Ministry of Economy, Energy, External Trade and Scientific Policy

Bulgaria, for the Ministry of Education and Science

Cyprus, for the Ministry of Communications and Works

Denmark, for the Danish Maritime Authority

Estonia, for the Ministry of Scientific Affairs

Finland, for the Ministry of Transport and Communication

France, for the Ministry of Transport, Equipment, Tourism and Sea

Germany, for the Federal Ministry of Education & Research

Greece, for the Ministry of Development, Secretariat General for Research and Technology

Hungary, for the Ministry of Education

Ireland, for the Department of Communications, Marine and Natural Resources

Italy, for the Ministry of Infrastructures and Transport

Lithuania, for the Ministry of Education and Science

Norway, for the Ministry of Trade and Industry

Poland, for the Ministry of Science and Information Technology

Portugal, for the Ministry of Science and Technology

Romania, for the Ministry of Transport

Spain, for the Ministry of Science and Education

Sweden, for the Swedish Maritime administration

Turkey, for the Ministry of Transport

### ► Commission Services

#### DG Research

Directorate H - Space & Transport, Unit H2 - Surface Transport

Directorate I - Environment, Unit I3 - Management of Natural Resources and Services

Directorate G - Industrial Technologies, Unit G2 - Products, processes, organisation

#### DG Transport & Energy

Directorate G - Maritime & River Transport; Intermodality, Unit G3, Motorways of the sea & intermodality

#### DG Environment

Directorate C - Air & Chemicals, Unit C1, Clean Air and Transport

#### DG Enterprise

Directorate H - Aerospace, security, defence and equipment, Unit H1, Aerospace, defence

#### DG Fisheries and Maritime Affairs

Directorate D - Control and Enforcement, Unit D3, Legal Issues

DG Information Society and Media

Directorate G - Components and Systems, Unit G4, ICT for Transport

# List of abbreviations

CAD/	Computer Aided or Assisted Design/
CAM/	Computer Aided Manufacture/
CIM	Computer Integrated Manufacture
DSS	Decisions Support Systems
EHM	Equipment Health Monitoring
EIA	International Energy Agency
ERA	European Research Area
FP6	Framework Programme 6
FP7	Framework Programme 7
HVAC	Heating/ventilation/air-conditioning/climate
ICT	Information and Communication Technologies
IP	Integrated Projects
IPR	Intellectual Property Rights
ITS	Intelligent Transport Solutions
JIPs	Joint Industry Projects
LCC	Life Cycle Cost
LNG	Liquefied Natural Gas
MIF	Maritime Industries Forum
NoE	Network of Excellence
"R"	Research
R&D	Research and Development
RD&I	Research, Development and Innovation
ROV	Remotely Operated Vessels/Vehicles
SME	Small and Medium Enterprises
SRA	Strategic Research Agenda
STREP	Specific Target Research Projects
TP	Technology platform
VLCCs	Very Large Crude(oil) Carrier
WB or W	WaterBorne
WSRA	Waterborne Strategic Research Agenda

# Photos reference

## *Cover page from left to right*

Photo 1: courtesy of Chantiers de l'Atlantique  
Photo 2: courtesy of TKMS/Peter Neumann-YPS  
Photo 3: courtesy of ECSA  
Photo 4: courtesy of ESPO  
Photo 5: courtesy of DNV  
Photo 6: courtesy of EURMIG

## *Page 4*

Photo: courtesy of Aker Yards

## *Page 6*

Photo: courtesy of Jiri Szeppan

## *Page 7 from top to bottom*

Photo 1: courtesy of Chantiers de l'Atlantique  
Photo 2: courtesy of Aker Yards  
Photo 3: courtesy of Hafen Hamburg Marketing/Sperber

## *Page 8 from top to bottom*

Photo 1: courtesy of Aker Yards  
Photo 2: courtesy of LINDENAU GmbH

## *Page 9 from top to bottom*

Photo 1: courtesy of BAE Systems  
Photo 2: courtesy of CESA

## *Page 10 from top to bottom*

Photo 1: courtesy of ENVC  
Photo 2: courtesy of Aker Yards  
Photo 3: courtesy of DNV

## *Page 11*

Photo: courtesy of TNO

## *Page 12 from top to bottom*

Photo 1: courtesy of TKMS/HDW  
Photos 2 and 3: courtesy of Deerberg Systems

## *Page 13 from top to bottom*

Photo 1: courtesy of Noretex  
Photo 2: courtesy of CTO  
Photo 3: courtesy of Vikoma International Ltd

## *Page 14*

Photos: courtesy of U.S. Coast Guard

## *Page 15 from top to bottom*

Photo 1: courtesy of ENVC  
Photo 2: courtesy of SSA  
Photo 3: courtesy of UENF

## *Page 16 from top to bottom*

Photo 1: courtesy of SAM Electronics  
Photo 2: courtesy of BAE Systems  
Photo 3: courtesy of NoE VISIONS

## *Page 17 from top to bottom*

Photo 1: courtesy of CESA.  
Photo 2: courtesy of VWS  
Photos 3 and 4: courtesy of Aker Yards

## *Page 18 from top to bottom*

Photo 1: courtesy of Rolls Royce  
Photo 2: courtesy of SAM Electronics  
Photo 3: courtesy of ESPO

## *Page 19 from top to bottom*

Photo 1: courtesy of EMEC  
Photo 2: courtesy of Atlas Elektronik  
Photo 3: courtesy of Fincantieri

## *Page 20 from top to bottom*

Photos 1 and 2: courtesy of BAE Systems  
Photo 3: courtesy of AVEVA AB

## *Page 21 from top to bottom*

Photo 1: courtesy of TKMS/HDW  
Photo 2: courtesy of BAE Systems  
Photo 3: courtesy of Fincantieri

## *Page 22 from top to bottom*

Photo 1: courtesy of CMT/DockLaser project  
Photo 2: Bottom: courtesy of MIZAR Oy  
Others: courtesy of Meyer Werft  
Photo 3: courtesy of ICOMIA

## *Page 23 from top to bottom*

Photo 1: courtesy of EUROGIF  
Photo 2: courtesy of SAM Electronics  
Photo 3: courtesy of Rolls Royce

## *Page 24 from top to bottom*

Photo 1: courtesy of AIM  
Photo 2: courtesy of Chantiers de l'Atlantique

## *Page 25 from top to bottom*

Photos: courtesy of EUROGIF

## *Page 26 from top to bottom*

Photo 1: courtesy of Nick Souza + Odense Steel Shipyard Ltd  
Photo 2: courtesy of Van Oord  
Photo 3: courtesy of ESPO

## *Page 27 from top to bottom*

Photo 1: courtesy of European Commission  
Photo 2: courtesy of IHC

## *Page 28*

Photo: courtesy of EMEC

## *Page 29 from top to bottom*

Photo 1: courtesy of UENF  
Photo 2: courtesy of Fincantieri

## *Page 30 from top to bottom*

Photo 1: courtesy of Nick Souza + Odense Steel Shipyard Ltd  
Photos 2 and 3: courtesy of FSG

## *Page 31*

Photo 1: courtesy of Nick Souza + Odense Steel Shipyard Ltd

## *Page 32 from top to bottom*

Photos: courtesy of Euda

## *Page 33*

Photo: courtesy of EURMIG

## *Page 35 from top to bottom*

Photo 1: courtesy of Lars Skaaning + Odense Steel Shipyard Ltd  
Photo 2: courtesy of Chantiers de l'Atlantique

## *Page 36 from top to bottom*

Photo 1: courtesy of SSA  
Photo 2: courtesy of EMF

**WATERBORNE<sup>TP</sup>** Secretariat

c/o CESA

Rue Marie de Bourgogne 52-54

B-1000 Brussels, Belgium

**WATERBORNE<sup>TP</sup>**  
WATERBORNE<sup>TP</sup>